



Energy Efficient Task Light

Final report for PSO 344-059

Logadottir, Asta; Ardkapan, Siamak Rahimi; Johnsen, Kjeld; Baadsgaard, Signe; Dam-Hansen, Carsten; Thorseth, Anders; Johansson, Håkan

Publication date:
2014

Document Version
Publisher's PDF, also known as Version of record

[Link back to DTU Orbit](#)

Citation (APA):
Logadottir, A., Ardkapan, S. R., Johnsen, K., Baadsgaard, S., Dam-Hansen, C., Thorseth, A., & Johansson, H. (2014). *Energy Efficient Task Light: Final report for PSO 344-059*.

General rights

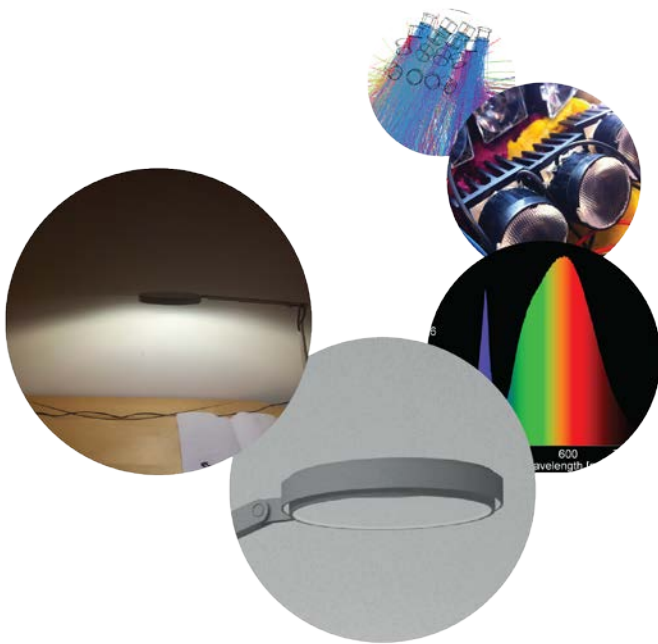
Copyright and moral rights for the publications made accessible in the public portal are retained by the authors and/or other copyright owners and it is a condition of accessing publications that users recognise and abide by the legal requirements associated with these rights.

- Users may download and print one copy of any publication from the public portal for the purpose of private study or research.
- You may not further distribute the material or use it for any profit-making activity or commercial gain
- You may freely distribute the URL identifying the publication in the public portal

If you believe that this document breaches copyright please contact us providing details, and we will remove access to the work immediately and investigate your claim.

Energy Efficient Task Light

Final report for PSO 344-059



Ásta Logadóttir, Danish Building Research institute, Aalborg University CPH

Siamak Rahimi Ardkapan, Danish Building Research institute, Aalborg University CPH

Kjeld Johnsen, Danish Building Research institute, Aalborg University CPH

Signe Baadsgaard, Lundgaard & Tranberg Arkitekter

Carsten Dam-Hansen, DTU Fotonik

Anders Thorseth, DTU Fotonik

Håkan Johansson, Fagerhult

COWI

DTU Fotonik
Department of Photonics Engineering

**LUNDBGAARD
& TRANBERG
ARKITEKTER**
PILESTRØDE 10, 3. SAL
1112 KØBENHAVN K
TELEFON 33 91 07 17
LTARKITEKTER.DK

September 2014

FAGERHULT



STATENS BYGGEFORSKNINGSINSTITUT
AALBØRG UNIVERSITET KØBENHAVN

Preface

This report contains a description of the work performed within the research & development project “Energy Efficient Task Light” and covers the final reporting of this project.

The project was carried out in a collaboration between Danish Building Research Institute, Aalborg University CPH (SBI, AAU), Lundgaard & Tranberg Arkitekter, DTU Fotonik, Fagerhult and COWI A/S. The project was led by: Mette Hvass, COWI for the first year and since December 2012 by Ph.d. Ásta Logadóttir, SBI, AAU.

The project was financed by the Danish Energy Association through Elforsk’s PSO program, under actions 3a. Lighting, 3b. Lighting control and 7. Behavior, barriers and tools. The project, number PSO 344-059, was initiated in March 2012 and ended in September 2014.

In the first part of the report a short resume of the project is given, describing the background and aim of the project, the work and results together with future perspectives of the results of the project. The report accounts for the design process, the development and description of the prototype and the user test. The prototype has been developed for user test purposes.

Ásta Logadóttir
SBI AAU, København, September 2014.

Forord

Denne rapport indeholder en beskrivelse af arbejdet i forsknings- og udviklingsprojektet "Energieffektiv arbejdslampe" og udgør den afsluttende rapport.

Projektet er udført i et samarbejde mellem følgende partnere: Statens Byggeforskningsinstitut, Aalborg Universitet CPH (SBI, AAU), Lundgaard & Tranberg Arkitekter, DTU Fotonik, Fagerhult og COWI A/S. Projektet har været ledet af: Mette Hvass, COWI i det første år, og siden december 2012 af Ph.d. Ásta Logadóttir, SBI, AAU.

Projektet er finansieret af Dansk Energi gennem Elforsks PSO-program, under indsatsområderne 3a. Belysning, 3b. Lysstyring og 7. Adfærd, barrierer og værktøjer. Projektet, nummer PSO 344-059, blev startet i marts 2012 og sluttede i september 2014.

Den første del af rapporten indeholder et kort resume af projektet, der beskriver baggrunden og formålet for projektet, det arbejde som er gjort og de resultater der er opnået samt de fremtidsperspektiver for resultaterne af projektet. Rapporten beskriver design processen, udviklingen og karakteriseringen af prototypen samt rapportering af brugertesten. Prototypen er udviklet med henblik på brugerundersøgelser af produktet.

Ásta Logadóttir

SBI, København, 11. september 2014

Content

| | |
|--|----|
| Preface..... | 2 |
| Forord | 3 |
| Content | 4 |
| Summary | 5 |
| Project Group..... | 6 |
| Background..... | 7 |
| Product specifications..... | 9 |
| Specifications according to standards | 9 |
| Design..... | 11 |
| Design and demonstration of the optical LED systems..... | 16 |
| Simulations | 16 |
| Lighting Mock-up | 16 |
| Asymmetric lens simulation | 17 |
| Realizing the lighting mock-up..... | 18 |
| Presence detection | 19 |
| Conclusions on LED optical design | 19 |
| Developing the prototype..... | 20 |
| Light performance..... | 20 |
| Thermal management..... | 22 |
| Durability | 23 |
| User test..... | 24 |
| Methodology | 24 |
| Experimental setup | 26 |
| Results | 27 |
| All data..... | 28 |
| Data for each of the task lights | 28 |
| Conclusion and Discussion | 29 |
| References | 30 |

Summary

The objectives of this work is to develop a task light for office lighting that fulfils the minimum requirements of the European standard *EN12464-1: Light and lighting – Lighting of work places, Part 1: Indoor workplaces* and the Danish standard *DS 700: Lys og belysning I arbejdsrum*, or more specifically the requirements that apply to the work area and the immediate surrounding area. By providing a task light that fulfils the requirements for task lighting and the immediate surrounding area, the general lighting only needs to provide the illuminance levels required for background lighting and thereby a reduction in installed power for general lighting of about 40 % compared to the way illuminance levels are designed in an office environment in Denmark today. This lighting strategy is useful when the placement of the task area is not defined in the space before the lighting is designed and the strategy also allows for the task area to be redefined in the space. The task lighting follows the task area as the developed task light is designed to be placed on the desktop of an office desk.

The work carried out within this project is the architectural design of the task light, the optical design of the light distribution, prototype production and user tests for comparison between the prototype and traditional task lighting luminaires.

The architectural design and user friendliness of the task light was a high priority within the project in order to promote market penetration of such a product. The height of the lamp head is aligned with respect to distribution and glare, which are two conflicting parameters. The broad distribution of the light requires a flat lamp head with the light source close to the bottom edge, while the desire to minimize glare is met by raising the lamp head and placing the light source as far from the bottom edge as possible.

The main results of the project show opportunities for energy savings in an office environment by reducing the installed power for the general lighting by applying a task light with a wide light distribution across the desk area, providing high illuminance uniformity. There is still work to be done on the prototype to optimize the energy consumption of the task light and measures need to be taken to minimize glare from the task light as well as reflected glare. The lamp head adjustment possibilities regarding tilting and turning result in problems with glare and these adjustment possibilities should be eliminated in the final product. In general, the adjustment possibilities for height, length ways and sideways are important aspects for task lights, however they become less important when the light distribution is as wide as for the prototype. Using only standard components in the prototype, the optimal light distribution for the purpose of meeting the requirements could not be obtained. The light distribution was approximated to the requirements by using combinations of different beam shaping lenses. A final product would benefit from custom made lenses, capable of providing the desired light distribution.

The user test shows that when working with general lighting of 100 lx in the room the developed task light with its wide light distribution provides flexibility in choosing a reading task area on the desk and provides more visibility to all objects on the desk than the two traditional reference task lights with LED retrofit light bulbs.

By utilising this new type of task light, the energy consumption by general lighting can be reduced by approximately 40 % by fully exploiting the lower illuminance levels required by lighting standards for the background lighting. The energy consumption of the task lights should be optimized for a wide light distribution while minimizing problems with glare.

Project Group

COWI was the initiator of this project and acted as a project manager until December 2012, since then COWI has been responsible for the finances of the project.

Lundgaard & Tranberg has been responsible for the architectural design of the prototype and has delivered sketches for the final product of the task light.

DTU Fotonik has been responsible for an example of an optical design of an LED system for asymmetric light distribution and a functional demonstration example thereof. Further DTU Fotonik has been responsible for characterisation of the task lamps and for the report layout.

Fagerhult has been responsible for manufacturing a prototype of the task lamp for research purposes.

SBi, AAU has been responsible for the project management since December 2012, for the review of lighting standards and regulations and for the user tests performed with the prototype.

Background

It has been reported that office lighting uses 21 kWh/m² per year in northern European countries. Various strategies have been proposed in order to reduce energy consumption for office lighting; among them using new energy efficient light sources and also, using task lighting (Dubois & Blomsterberg, 2011). Light emitting diodes (LED) technology is considered as a new energy efficient lighting technology that can reduce energy and also has a long working life in comparison to traditional light sources. The other strategy of reducing energy consumption for lighting is to use task lights and reduce the ambient lighting. The idea is to illuminate tasks by specified task lights that provide the necessary illuminance to perform the task and provide a feeling of wellbeing while performing tasks. Energy saving is a result of reduced ambient lighting that provides the background lighting in the remaining part of the working space.

Commonly used metrics to evaluate the lighting condition are illuminance level, correlated color temperature (CCT), colour rendering index (CRI), glare rating and illuminance uniformity. Veitch and Newsham's study from 1998 suggests that the combination of desk lighting with ambient lighting is a reasonable strategy to keep satisfaction while reducing energy consumption (Veitch & Newsham, 1998). A study by Akash and Boyce (2006) supports these findings and shows that reducing ambient lighting may increase satisfaction if the task light is available.

According to Bean and Hopkins (1980), the minimum illuminance level provided in any continuously used interior, where 50 % of the subjects are satisfied, is 200 lux. In addition, according to this study, subjects are more satisfied when the task and ambient illuminance levels are equal. This minimum value of 200 lux is reduced due to the addition of computer tasks in the workplace (Veitch & Newsham, 1996).

However, many studies have not found effect of illuminance level on reading task performance (Horst, Silverman, Kershner, Mahaffey, & Parris, 1988; Kaye, 1988; Rea & Ouellette, 1991).

According to European Standard of light and lighting EN12464-1 (2011), maintained average illuminance value (E_m) is 500 lx for activities of writing, typing, reading and data processing (task area) in offices. Illuminance on the immediate surrounding area is required to be 300 lx. Immediate surrounding area is a band with a width of 50 cm around the task area in the view of direction. The maintained illuminance value of background area (which is a 3 m band adjacent to immediate surrounding) should be 1/3 of the illuminance on the immediate surrounding area i.e 100 lx. According to this standard, illuminance level for walls should be more than 75 lx and for ceiling should be more than 50 lx.

According to DS 700:2005 (2005), the minimum maintained illuminance is 500 lx for task area, 200 lx for the immediate surrounding area and 100 lx for the background area. The size and placement of the areas is to be decided by the lighting designer.

Illuminance uniformity on working desk has been investigated by Slater and Boyce (1990). According to their study, comfort satisfaction is increased at higher illuminance uniformities. In addition, for tasks which occupy only the central part of a desk, illuminance uniformity can be relaxed to 0.5 across the desk with little risk of complaint, while the illuminance uniformity is suggested to be 0.7 for tasks which cover the whole desk.

For the task area, European Standard of light and lighting DS_EN12464-1 has determined minimum illuminance uniformity value (U_0) of 0.60. U_0 is a ratio of minimum illuminance to average illuminance on a surface. Minimum U_0 is 0.4 for the immediate surrounding area and 0.1 for the background. There is no U_0

value requirement for task area in DS 700:2005. However, for the immediate surrounding area and the background, illuminance minimum to maximum ratio should be between 0.20 and 0.70.

When designing office lighting in Denmark the common method amongst practitioners is to provide the requirements for the immediate surrounding area across the room and then write into the lighting proposal that a task light should be provided for every office task station in the room, thereby allowing the task light to provide the additional illuminance levels required by DS700:2005 for task area. This secures diversity in the lighting conditions in the room and limits the energy use compared to the provision of the task illuminance provided by the general lighting in the entire room.

This project takes the process of designing illuminance levels in the room one step further by promoting even lower illuminance levels required by the general lighting, namely providing the requirements for background lighting instead of the lighting for immediate surroundings (1/3 of the illuminance level according to EN12464 and 1/2 according to DS700). It is the intention of this project to design a task light that provides the illuminance requirements of the standards (EN12464 and DS 700) for task area and immediate surrounding area, leaving the general lighting installation to cover the requirements for background lighting. This will amount to a 50 % reduction in illuminance levels and corresponding reduction in energy use for general lighting according to the common practice of lighting design in Denmark.

Product specifications

From the beginning of this project the plan was to make use of the Danish tradition of using task lights actively in the light planning of a space. At the current moment, Denmark has an A-deviation within the European standard EN 12464-1:2011 (CEN, 2011), due the Danish Building Regulations (BR10, 2014) stating that the use of DS 700 series for lighting is mandatory. However, the developed task light should not be limited to the Danish market, complying with DS 700, Artificial lighting in workrooms (2005). To secure the accessibility of the product to at least the European market, the European norm EN12464-1 has also been reviewed with respect to specifications for the task light. The product specifications comply with both DS 700 and EN12464-1 and will be explained in the following section on *Specifications according to standards*. The design of the optical system was dependent on the specifications from the standards and the process of determining the optical system components is described in the section *Design of the optical system*. The architectural design and user friendliness of the task light was a high priority within the project in order to promote market penetration of such a product. The architectural design is described in the section *Design*.

Specifications according to standards

The developed task light should provide illuminance levels, uniformity, glare index, and colour rendering according to the lighting standards shown in Table 1. The table shows the requirements for the two standards and the product specifications for the developed prototype. EN12464-1 uses maintained mean illuminance for task, immediate surrounding and background area while DS700 uses maintained minimum illuminance for the task area and mean illuminances for immediate surrounding and background area.

Table 1. Standards and lamp specifications. In the table E [lx] stands for maintained mean illuminance and U_0 represents ratio of minimum illuminance to average illuminance unless otherwise specified.

| Requirements | EN12464-1:2011 | DS 700:2005 | Product requirements |
|-----------------------------------|----------------|-----------------------|----------------------|
| Task | | | |
| E [lx] | 500 | 500 ¹⁾ | 500 |
| U_0 | 0,6 | - ²⁾ | 0,6 |
| Glare | UGR < 19 | NG < 20 | |
| CRI | 80 | 80 | 80 |
| Immediate surrounding area | | | |
| E [lx] | 300 | 200 | 300 |
| U_0 | $\geq 0,40$ | 0,2-0,7 ³⁾ | $\geq 0,40$ |
| Background area | | | |
| E [lx] | 100 | 100 | 100 |
| U_0 | $\geq 0,10$ | 0,2-0,7 ³⁾ | $\geq 0,10$ |

¹⁾ maintained minimum illuminance

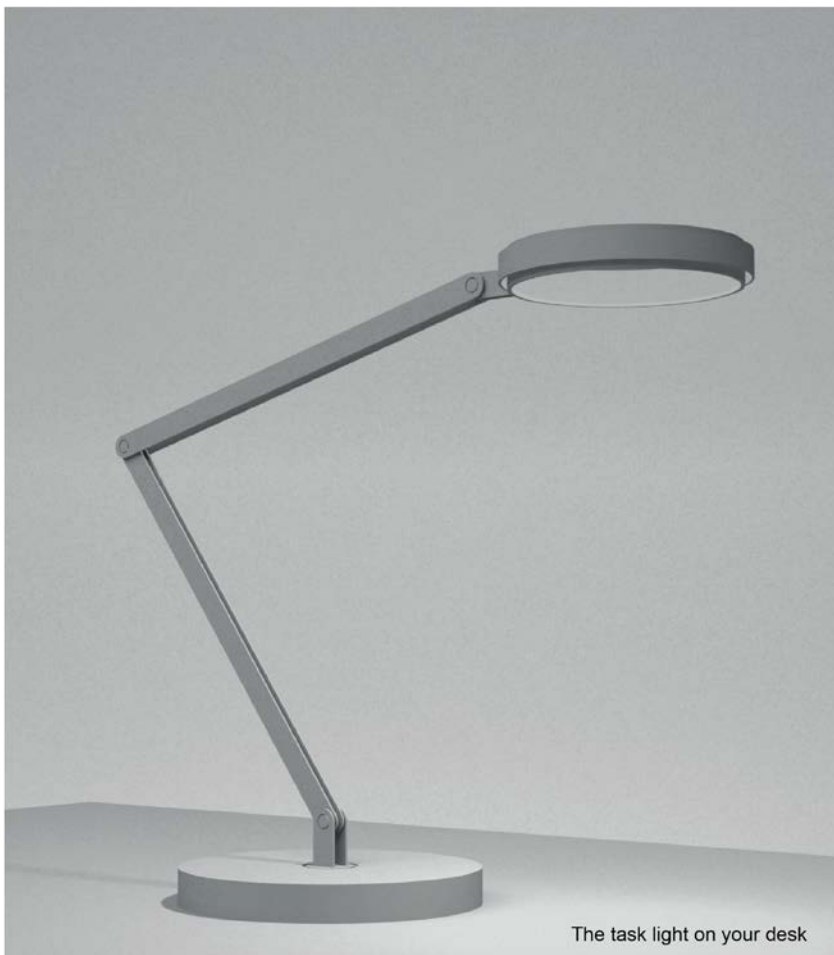
²⁾ In practice a few points in the illuminance grid of the task area may go down to 25% below the task illuminance

³⁾ ratio of minimum illuminance to maximum illuminance

The size of the task, immediate surroundings and background area are according to the standards shown in Table 2. For both standards, the size of the task area is to be determined by the lighting designer while the immediate surrounding and background area are more precisely described in EN12464-1 than in DS 700. For this application, the task area was determined to be a reading task of a text on an A4 paper size and also an area covering 60 x 60 cm of the desk area.

Table 2. Standards and product specification for size of areas.

| Specification | EN12464-1:2011 | DS 700:2005 | Product requirements |
|------------------------------------|---|------------------|---|
| Size of task area | To be determined | To be determined | A4 paper size 60 x 60 cm area |
| Size of immediate surrounding area | 0,5 m surrounding task area in the viewing direction | To be determined | 0,5 m surrounding task area in the viewing direction |
| Size of background area | 3 m surrounding immediate surrounding area, within the limits of the room | To be determined | 3 m surrounding immediate surrounding area, within the limits of the room |



Design

The ambition to create a task light that can reduce the energy consumption in offices, and utilize the long lifetime of the LED, indicates that this is a luminaire that will stay with the user for many years. The idiom must therefore be simple and timeless without excessive ornamentation or overly designed shapes that refer to a certain time period or fashion flow. Instead the quality and identity of the luminaire is given by the simple and precise detailing and the high quality and texture of the material.

The task light should be a good friend, and not an alien, who has occupied the user's desk, and the design of the luminaire is therefore based on ideas of honesty, familiarity, and simplicity. It must be obvious how the task light works, and it should be flexible enough to be operated with a single hand, without having to look away from the work being performed. This calls for a rather traditional disposition of the luminaire, with a flexible arm and a lamp head that is easy to grab and move around.

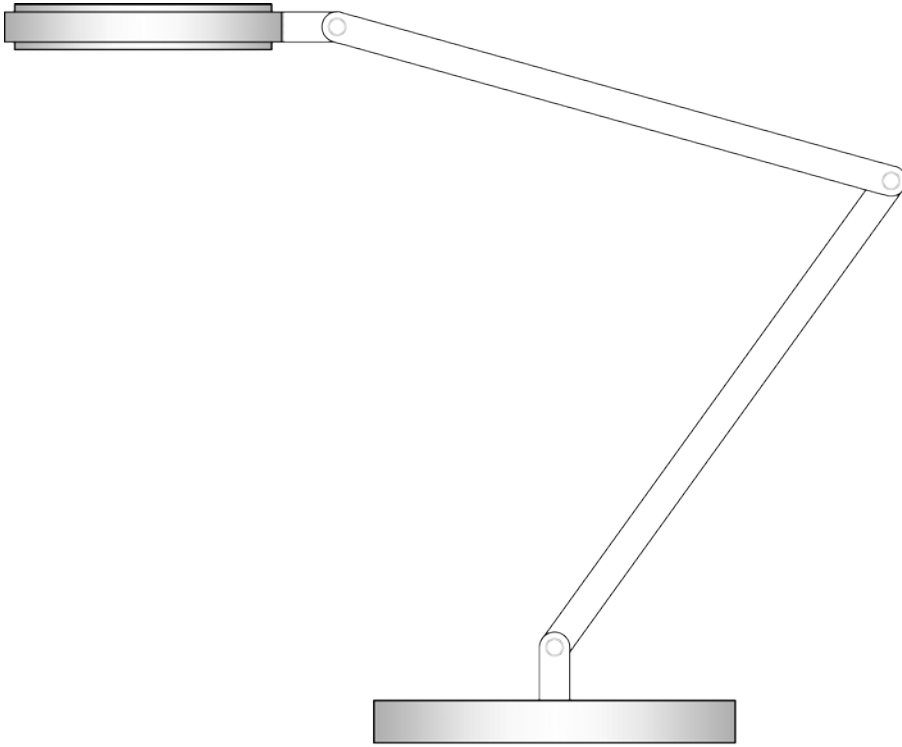
The arm has three joints that connect the lamp head to the upper arm, the upper arm to the lower arm and the lower arm to the base of the task light. These three joints rotate in two directions; up and down. The joint that connects the lower arm to the lamp base is placed on a rotating disc with a rotation angle of 360 degrees around a vertical axis. This allows for adjusting the luminaire to any desired position, effortless and with a single hand.

The lamp head is encircled by a ring that makes it easy to grab and move around without leaving fingerprints on the diffuser. The on/off switch is placed on top of the lamp head in order to ensure that it is always within your reach. The single round button is flush with the surface, and besides the on/off switch it also operates the dimmer. On the opposite side of the lamp head, flush with the diffuser, is the presence detection. This feature ensures that the light will burn only when a person is present at the work desk. The energy waste is hereby brought to a minimum.

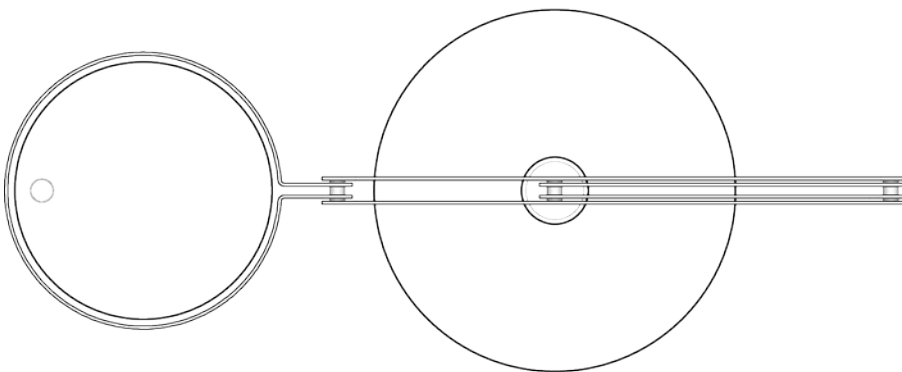
It is important that the design of the luminaire reflects what kind of light source is used, and how the light is distributed from the fixture. Consequently, the flat nature of the lamp head is generated by the minimal space requirements of the LED light source, while the round shape of the head reflects the circular characteristic of the light coming out.

The height of the lamp head is aligned with respect to light distribution and glare, which are two conflicting parameters. The broad light distribution requires a flat lamp head with the light sources close to the bottom edge, while the desire to minimize glare is met by raising the lamp head and placing the light sources as far from the bottom edge as possible. The design and proportions of the lamp head meet both of these requirements.

The lamp head surface serves as a heat sink for the LED, and the surface size is therefore determined by the cooling needs of the diodes. The lamp head will never get too warm to grab and adjust. The driver and transformer are placed in the lamp base.



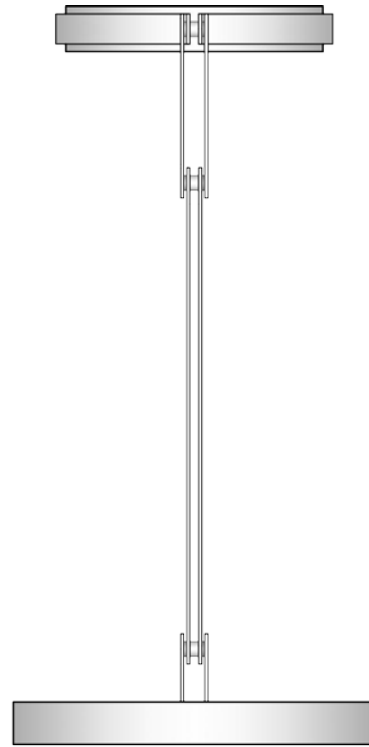
Side elevation
Scale 1:5



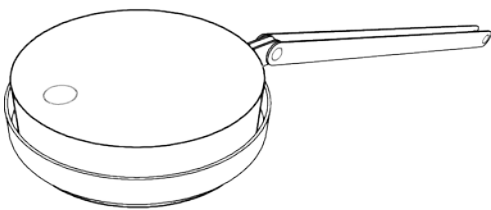
Top view
Scale 1:5



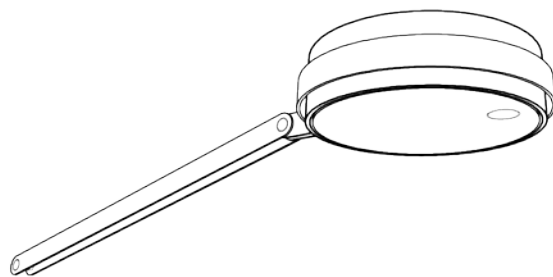
Front elevation
Scale 1:5



Back side elevation
Scale 1:5



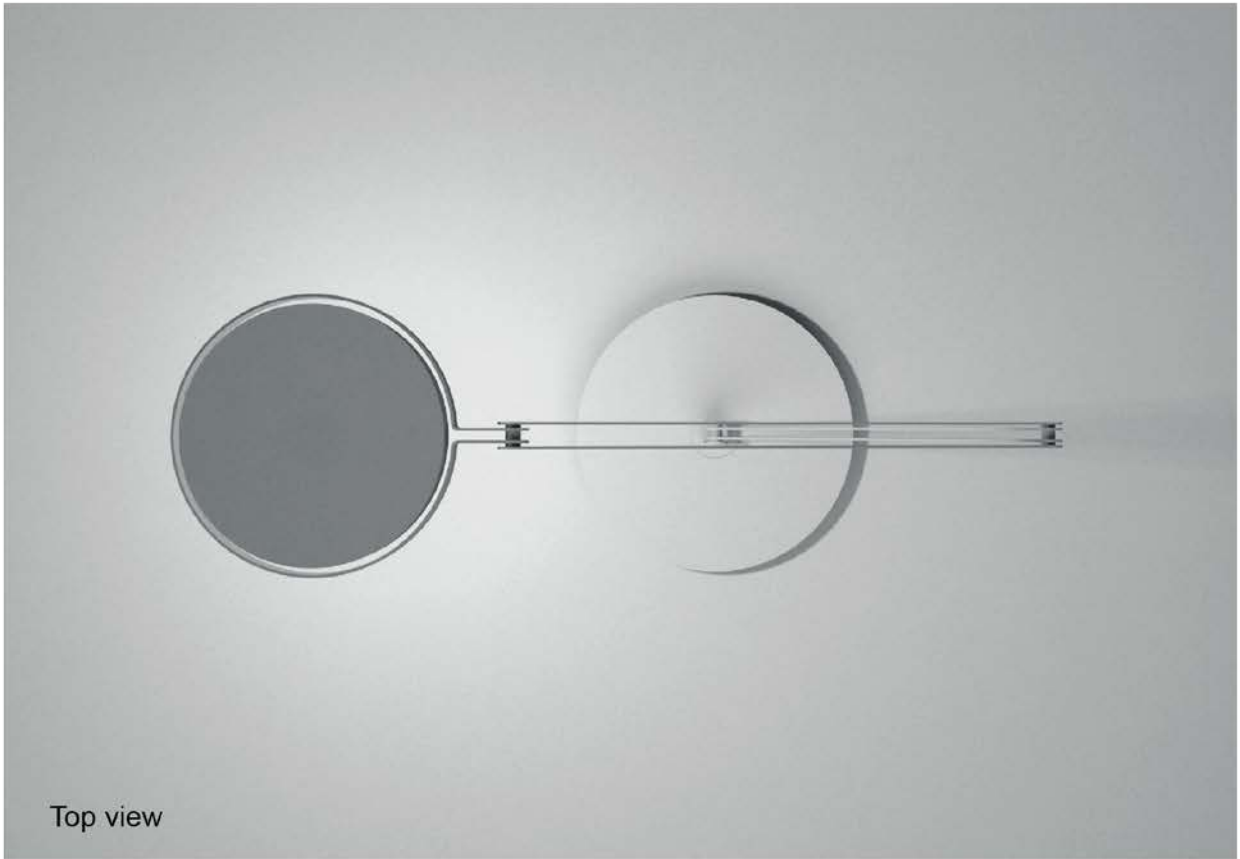
On/off switch and dimmer
on top of the lamp head



Presence detection
flush with the diffuser



Side view



Top view



Design and demonstration of the optical LED systems

The demands outlined in the section *product specification* sets the requirements for the light distribution. Task lighting for offices in Denmark has traditionally been achieved with a light bulb in a reflector luminaire, giving a diffuse light distribution, with high light intensity directly under the lamp head and with lower intensity towards the periphery of the lit area. The lighting concept described in this report requires high luminous intensities, in order to get the illuminance levels required for the task area e.g. 500 lx according to product specification. It was the aim of the work of DTU Fotonik to provide the technical foundation for the further work. Answering the questions:

- How would the lighting distribution on a surface look and be perceived?
- How could the asymmetric and skew angle light distribution be realized?

Furthermore the work included exploring the possibility of including a motion sensor and what the operating principle of such a motion sensor on a task light would be. A physical based ray tracing program, Zemax, has been used for simulations in the optical design process.

Simulations

Lighting simulation has been an important tool in the work, since building prototype LED luminaires is a time consuming and expensive way to test new ideas. Using light simulation software, components, e.g. LEDs and lenses can be downloaded from the manufacturer and used in numerous configurations, and the resulting light distribution can be studied before any attempt is made at realizing a physical prototype or a final product. Two different approaches have been employed in order to obtain the desired asymmetric light distribution, the first using LEDs with rotationally symmetric lenses, illuminating the task area at different angles and the other using asymmetric LED lenses.

Lighting Mock-up

To get a feeling of how such a light distribution would look and be perceived with the set specification, a lighting mock-up was created. The intent of the lighting mock-up was to get a sense of the light distribution without incorporating the design of the physical luminaire. The mock-up was first simulated using standard lens components with symmetric light distributions, which was angled to give the optimal directionality and the LED light output was then scaled to give the desired distribution. Lenses with small beam angles were used for the high intensity directions and large beam angles were used for the more traditional illumination of the work surface in the immediate surroundings of the luminaire. The concept of ray tracing is illustrated in Figure 1a, and an example result of simulated light distribution from symmetric lenses is shown in Figure 1b. The realization of this task light is described in the section "Realizing the lighting mock-up".

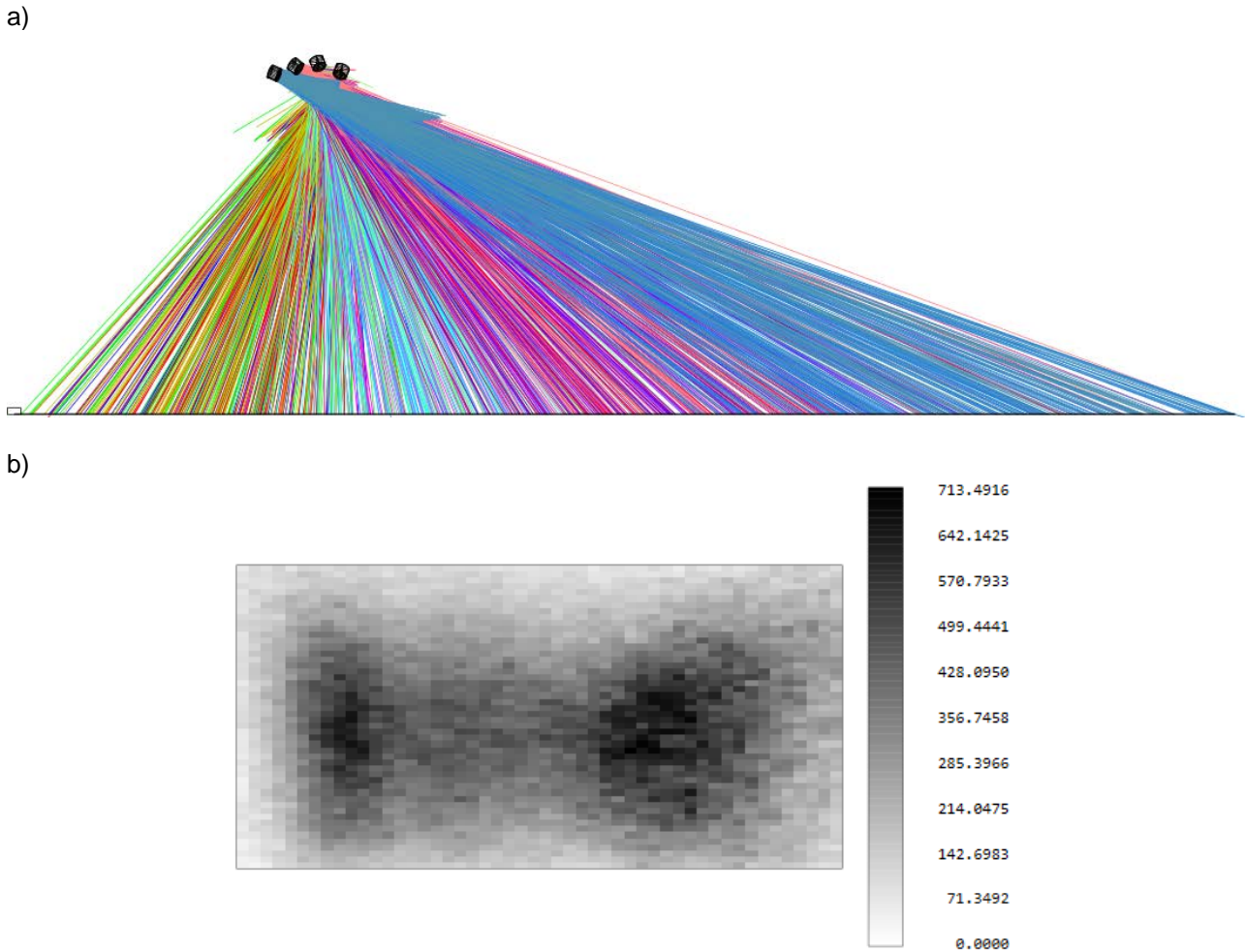


Figure 1. Visualization of the ray tracing of the lighting mock-up different LEDs have differently colored rays a). Simulated illuminance distribution on task from symmetric lenses b).

Asymmetric lens simulation

The non-standard light distribution would ideally be realized with a custom built lens. This approach would be the most energy effective in a final product. However development of custom LED lenses is outside the scope of this project. As an inspiration for the development of a prototype developed by Fagerhult, DTU Fotonik provided simulation using off-the shelf asymmetric lenses. This type of lenses is usually used for street lighting since this application often requires asymmetric light distributions. The LEDs used in the below simulation are:

- LEDiL, STRADA-SQ-T-DN-XP
- Carclo, Hubble2 37.0mm Asymmetrical Freeform (12587)

The light distribution files from the supplier were used to make ray tracing simulations in the Zemax software, with the lens data used as an emitter placed on a horizontal plane. The light output of each lens was adjusted then to get the resulting illuminance distribution on the task, shown in Figure 2. The work surface was then divided in two sections and the average illuminance of each was calculated. The result is shown in Figure 3.

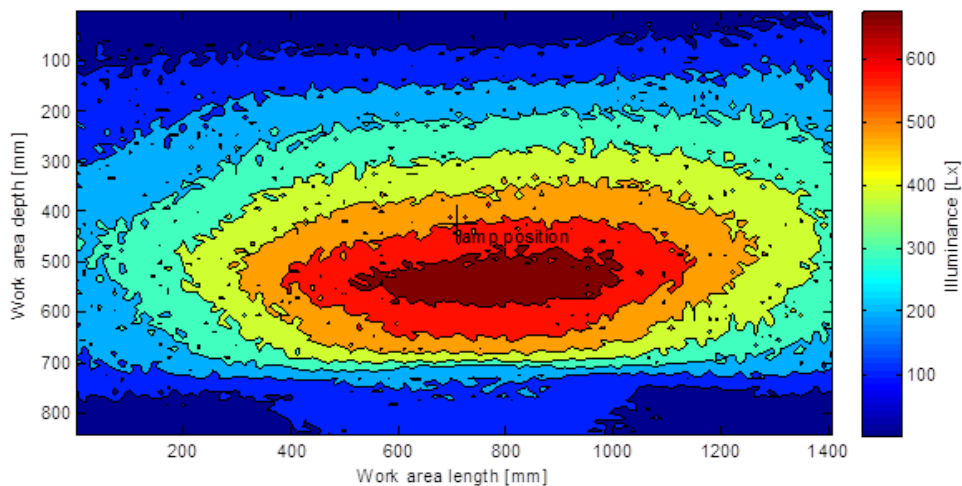


Figure 2. Simulation of the illuminance on the work area under a combination of two lens systems.

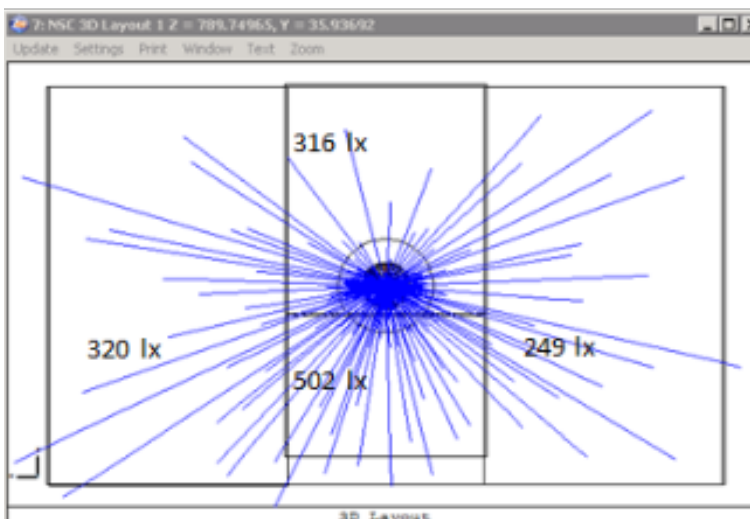


Figure 3. Screenshot from the ray tracing software annotated with mean illuminance values in the different sections.

Realizing the lighting mock-up

Using the designed LED optical system illustrated in Figure 1, DTU Fotonik constructed a mock-up task light, see Figure 4, capable of providing a light distribution close to the calculation in Figure 1. This was achieved using modules of single white CREE Xlamp LEDs, with various lenses and mounted with individual 2.5 cm x 2.5 cm x 1.7 cm heat sinks. The directionality was provided by inserting the modules into a base of modelling compound (Play-doh), and pointing the light distribution of the individual LED components in the desired direction. The 12 LED modules were powered in four groups corresponding to different parts of the illuminated task area and the lamp head mock-up was mounted on a tripod. This solution did not provide an accurate light distribution or a realistic looking lamp head. The intention with this mock-up task light was to give the architects a sense of what the light distribution would look like and possible aspects to avoid, such as glare.



Figure 4. The lighting mockup was presented to the project partners at the meeting at Fagerhult in Habo, Sweden.

Presence detection

Further energy savings were discussed in the project group by implementing a motion sensor in a final product. The mechanism of such a sensor would decrease the light level and there by power consumption, when no motion was detected near the task light. The presence detection would be localized to the area where the light would be needed by placing the motion detection field overlapping with the light distribution. A motion sensor was not included in the tested prototype due to the aim of the user test being focused on light distribution.

Conclusions on LED optical design

The two proposed designs of LED optical systems are shown to be able to yield a light distribution and illuminance levels on the task close to the prescribed product specification. A lighting mock-up based on the LED optical design has been built and used for visual investigations by the architects. The design and demonstration of the LED optical systems served as inspiration for the prototype of the task light, described in the following.

Developing the prototype

The prototype was mainly produced to support the user tests. With that in mind the prototypes should be used during a period of a couple of months and the focus was set on the following three criteria's

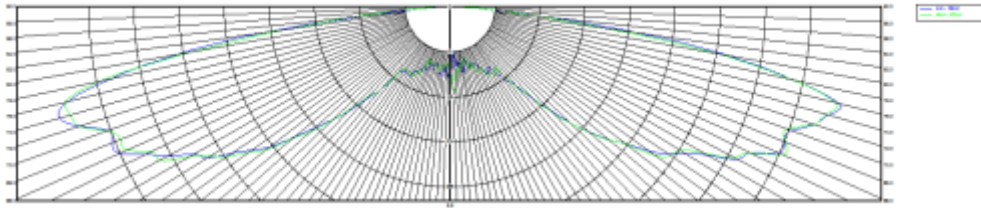
- Light performance according to the product specification
- Thermal management
- Durability

The prototype was originally to be made like the design sketches but during the first phase it was discovered that the material density due to cooling could be reduced greatly due to use of self-cooling LED's rather than the LED's described in the section about *design and demonstration of the optical system*. This opened for a lighter and slimmer look of the lamp head. Due to the self-cooling diodes there was no need for a handle on the lamp heads side, so that was also removed from the design sketches. This action made the lamp head less complex, it speeded up the making of the prototype and with less detail it also became less fragile and easier to handle in the user test.

Light performance

During the user test the subjects should evaluate the light distribution and therefore it was very important that the prototypes light distribution was very close to the target. Each prototype was equipped with a dimmer so the light level could be adjusted, on site, to perform according to the specification.

Normally in a final product with this level of innovation, tailor-made lenses and printed circuit boards (PCB's) are developed and used. However, due to the limited time available within this project, lenses and PCB's that existed on the market were used for this prototype. Despite the use of non-tailor-made lenses and PCB's, the result was close to the specifications made for the prototype and estimated by Fagerhult to be close enough to be evaluated by an external group. To match the existing components with the product specification, tests were performed in Photopia software to check the light distribution before producing the prototypes, see Figure 5.



LUMENS EXITING SYSTEM:

| Lumens (%) | Reaction |
|---------------|----------|
| 0 (0.0%) | 0 |
| 0 (0.0%) | 1 |
| 0 (0.0%) | 2 |
| 0 (0.0%) | 3 |
| 2087 (53.5%) | 4 |
| 16 (0.4%) | 5 |
| 101 (2.6%) | 6 |
| 13 (0.3%) | 7 |
| 185 (4.8%) | 8 |
| 24 (0.6%) | 9 |
| 77 (2.0%) | 10 |
| 21 (0.5%) | 11 |
| 20 (0.5%) | 12 |
| 23 (0.6%) | 13 |
| 21 (0.5%) | 14 |
| 16 (0.4%) | 15 |
| 2608 (66.9%) | Total |

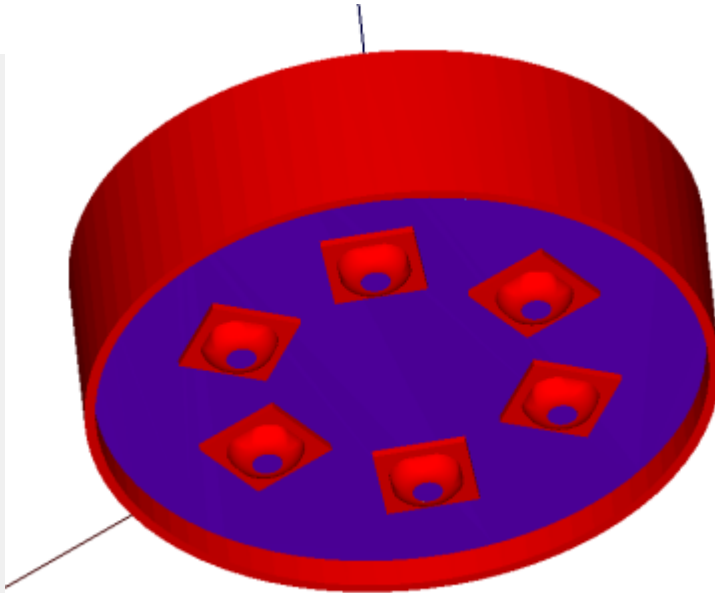


Figure 5. Photopia calculations with the first size of lamp head.

The diodes were positioned at 1.5 centimetre elevation from the edge of the lamp head, see Figure 6. The placement is used to create a mechanical cut off which reduces the immediate glare from the LED package.

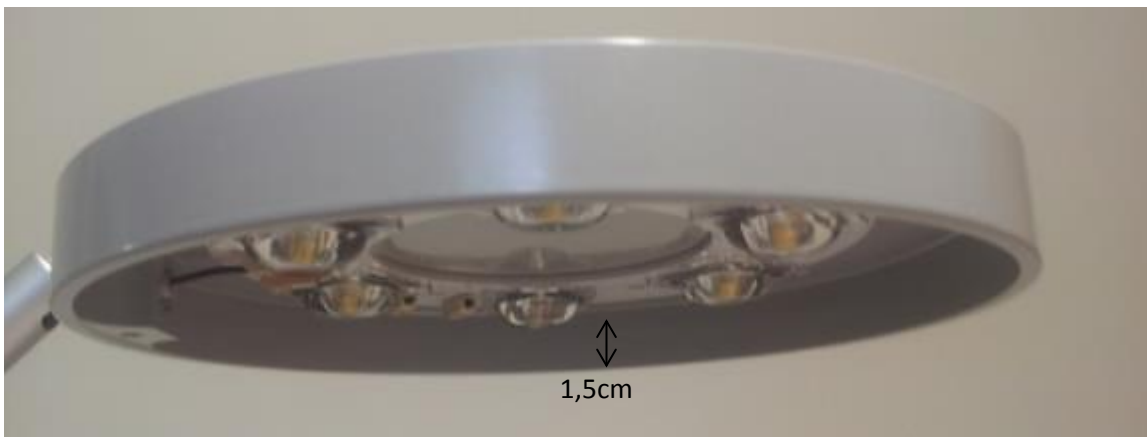


Figure 6. Mechanical cut off.

Parallel to Photopia, tests were also performed for thermal simulation where the expected amount of heat sink turned out not to be necessary. The size of the lamp head was therefore reduced dramatically compared to the original design. This had effect on the prototype durability, as there is less weight to handle for the joints. Finally the prototype was measured in a goniometer providing a digital light curve (ldt-file) that could be implemented in the light calculation software Dialux.

The LED's used in the prototype were 6 pcs Luxeon M 3000K CRI80 placed on a circular PCB. Each diode produced a flux of 800lm. The diodes were dimmed down internally with a resistance to give a net lumen package of 2600lm. Lenses used were of type Ledil Strada. The driver used for the prototype was a Tridonic LCAI 55W; it was placed in an external driver box with a dimmer button to be able to adjust the light level individually for each task light.



a)



b)



c)

Figure 7. Diodes on PCB a). Single diode b) Lens c)

Thermal management

The duration of the user test was not decided when the prototype was developed therefore, the thermal management was important in order to have a reliable product during the entire test period. Heat sink was estimated crucial to secure the life time of the diodes. The prototype must cool down the LED's in a proper way otherwise the LEDs will drop in luminous flux or reach the end of their lifetime. Thermal measuring was performed on the prototype to make sure that the critical point did not exceeded the thermal values given by the component suppliers. The thermal management test was performed via a handheld device with nodes attached to the measuring points. It was done in normal room temperature and the luminaire had been burning for a set time to reach maximum temperature.

To transport the heat out of the lamp head a thermal bridge and mechanical fixings was used between the PCB and the lamp head. The lamp head was made of machined aluminium to get the best heat sink.



Figure 8. Lamp head.

Durability

Given the fact that the prototypes should be used in a realistic environment the durability needed to be on a higher level than normal for a prototype. Early in the prototype design process, the decision was taken to go for solid materials instead of normal prototype material such as SLS plastic etc. The lamp foot was made in solid iron core with an outer housing of aluminium to create stability and a good finish. The Lamp arm was made in extruded anodized aluminium with joints levelled by springs. The lamp head is made in machined solid aluminium and painted grey. To have a good flexibility on the test site the prototype was made to be adjustable in both high, length way and sideways. The lamp head can also be tilted and turned.



Figure 9. Prototype being assembled by an engineer.



Figure 10. Final prototype lit on the test site in Copenhagen

User test

The aim of the user test was to evaluate occupant satisfaction and subjective task performance using a task light that provides more uniform light distribution on the working desk than generally provided by traditional task lights. The tested task light is designed to provide the requirements of lighting standards EN12464-1 and DS 700 according to section on *product specification*. The comparison was performed by subjective evaluation, using questionnaires to evaluate the prototype compared to the other task lamps. The test only addresses LED light sources, the developed task light and two LED retrofit light sources available on the market.

Methodology

The light distribution of the developed task light was evaluated by comparison to two other task lights. The reference task lights were typical task lights used in Denmark. The light sources were similar but had slightly varying lighting characteristics, such as: light distribution, CCT, Ra, mean illuminance on task area, see Table 3. According to the table the nominal correlated colour temperature of all three lamps was 4000 K. The first reference light source (RL 1) was a High-end LED retrofit bulb with plastic cover. The second reference light source (RL 2) was an adjustable LED retrofit bulb that was adjusted as far as possible to the CCT of the test luminaire and the luminous flux was also adjusted as far as possible to achieve a mean value for illuminance of 500 lx on the task area.

Table 3. Technical specifications of the three lamps, test task light (TL), reference task light 1 (RL 1) and reference task light 2 (RL 2).

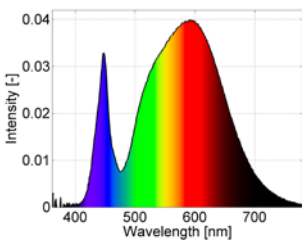
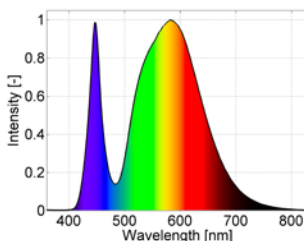
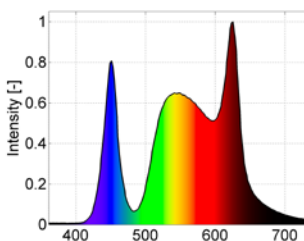
| Task light | TL | RL 1 | RL 2 |
|-----------------------------|---|---|--|
| Spectral power distribution |  |  |  |
| Power usage (W) | 11.2 | 7.8 | 5.5 |
| CRI | 78 | 73 | 83 |
| CCT | 3770 | 3960 | 3944 |
| Nominal CCT (K) | 4000 | 4000 | 4000 |
| Luminous flux (lm) | 835 | 585 | 336 |
| Luminous efficacy (lm/W) | 75 | 75 | 61 |

Figure 11 shows the placement of the lamp head, task area 1 (TA1), task area 2 (TA2) and task area 3 (TA3) on the desk. Task area 3 covers an area of 60x60 cm, while each of the two other task areas covers the area of an A4 paper size. The placement of the lamp head was determined based on having average illuminance level of 500 lx on Task area 1. All the lamp heads were placed at the same height of 37 cm above the table top.

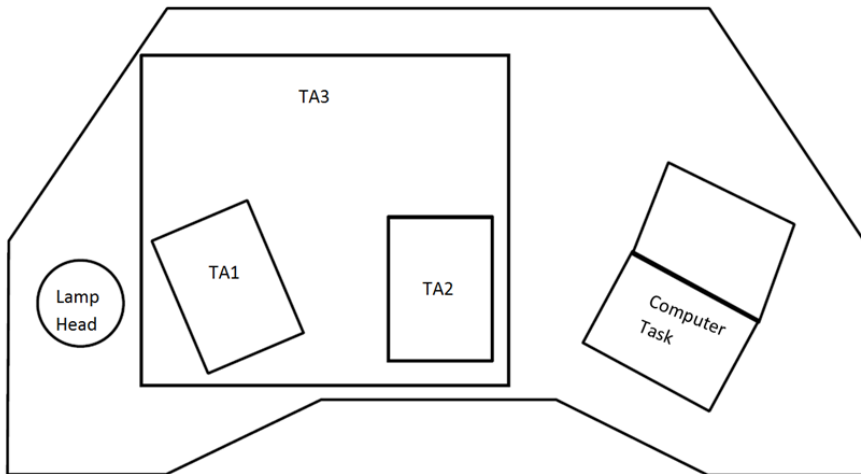


Figure 11. Task area (TA) 1, 2 and 3 used in the experiment.

Table 4 shows measured mean illuminance (E_m) and uniformity (U_0) values for the three luminaires in Task Area 1, 2 and 3, immediate surroundings and background. The E_m of TA 1 is regulated to fulfil the European standard requirement i.e. 500 lx. E_m values of other task areas measured accordingly. The determined immediate surrounding was a 50 cm band around TA 3. Due to the size of the room partitioning, the background was considered an area with dimensions of 3 × 2 m adjoining to the immediate surrounding area.

Table 4 shows that in task area 2, the illuminance level (E_m) is reduced to less than 200 lx for RL1 and RL2 while the E_m for the test light (TL) is 408 lx. Also, none of the task lights provide the 500 lx on task area 3, TL provides $E_m = 444$ lux and the reference task lights provide just above 300 lx. For the immediate surrounding area the test light provides more than the required 300 lx but the reference lights lie below the requirements with $E_m = 279$ lx (RL 1) and 232 lx (RL 2). The background values for the three luminaires fulfil the requirements of the EN12464-1 standard.

The illuminance uniformity calculated for the test light exceeded the required minimum value by the standard in all cases. The reference light sources only apply to the required illuminance uniformity at task area 2. RL 2 also meets the requirements for the immediate surroundings and both reference task lights meet the requirements for the background.

Table 4. Illuminance and uniformity of the three task lights at Task Area 1 (TA1), Task Area 2 (TA2), Task Area 3 (TA3), immediate surroundings and the background.

| Task lamp | | TL | RL 1 | RL 2 |
|-----------------------|------------------|------|------|------|
| TA1 | $E_m(\text{lx})$ | 500 | 531 | 502 |
| | U_o | 0.8 | 0.58 | 0.55 |
| TA2 | $E_m(\text{lx})$ | 408 | 181 | 186 |
| | U_o | 0.8 | 0.68 | 0.76 |
| TA3 | $E_m(\text{lx})$ | 444 | 315 | 307 |
| | U_o | 0.8 | 0.44 | 0.45 |
| Immediate Surrounding | $E_m(\text{lx})$ | 337 | 279 | 232 |
| | U_o | 0.51 | 0.34 | 0.43 |
| Background | $E_m(\text{lx})$ | 167 | 132 | 127 |
| | U_o | 0.57 | 0.61 | 0.61 |

Experimental setup

The experiment was performed in a room furnished as an office with dimensions of 4.4 × 5.8 × 2.7 m. Figure 12 shows a picture of the room. The window of the room to the outdoor was blocked completely with curtains. There were two windows to the nearby corridors that were blocked as much as possible using venetian blinds. Four ceiling luminaires with each having one active fluorescent tube were used. According to the information provided by the manufactures of the ceiling luminaires, the power usage, CCT and CRI of the ceiling luminaires were 18 W, 3000 K and 83 respectively.



Figure 12. A picture of the room.

The experiment included the participation of 36 test subjects in 12 groups of three participants each. The three test subjects in each group started the experiment at the same time sitting at desks A, B or C and they were asked to read a text which was placed at task area 1 (see Figure 11) using one of the task lights. Before starting the test, the subjects were informed that they were participating in a test about office lighting. The subjects were informed about the procedure in the hallway, just before the experiment started. The average illuminance level was 250 lx in the hallway. They were asked not to move task lights, table height, reading material and computer, but they were allowed to adjust the height of the chair to prevent glare.

The text provided to the subjects was printed in black on white paper, using Times New Roman font, point size 11.5, and a single line spacing.

The subjects started reading the text from Task area 1 for five minutes, and after that they answered a questionnaire using a laptop available to them on the desk (computer task). When subjects were answering the questionnaire, they were asked to put the text at reading Task area 2 within the marked frames. Then the participants filled the questionnaire regarding Task area 2. The reading task and answering the questionnaire for each luminaire was performed in less than 15 minutes.

The subjects answered questions about satisfaction, comfort, brightness, task performance, and adequacy of the lighting for the two reading task areas, computer task and desk perception. Subjects were also asked about glare and flicker.

After answering the first questionnaire, the test subjects moved to the next desk to repeat the same procedure, each subject evaluated all three task lights. The order of subjects sitting at the desks was randomized.

Of the 36 subjects, 17 were male and 19 were female. They all came from Aalborg University, either as students or staff, aged between 22 to 59 with the mean value of 32.8 years.

Objects such as pens, notebooks and computers were placed identically on the three desks in order to minimize bias from real condition. Photos of the desks can be seen in Figure 13. These pictures present the reading task placed at reading Task area 1.

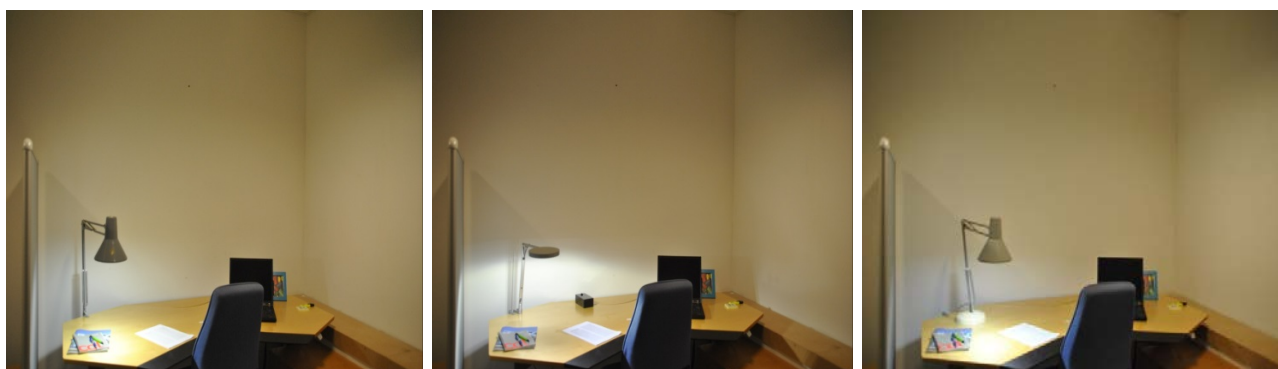


Figure 13. Photos of the three luminaire. Before every trial of three subjects the task lamps were placed randomly on the three desks.

The software SurveyXact (2014) was used in order to make the questionnaires and to gather the data. The questionnaires were sent directly to the email of participants in the experiments. Therefore, each participant filled one questionnaire for each of the three task lights. The analysis of the collected data was performed using SPSS Statistics.

Results

The following text describes the results of the questionnaire, first for all data pooled together providing the general overview of subjects' ratings for the task lighting and then the differences between the different task lights. The data is further described using frequency diagrams where the Y-axis presents the percent of answers to each statement presented on the X-axis for each type of task light.

All data

The results based on the mean value of the complete dataset, show that subjects generally considered the text as 'clear' to read at task area 1 and between 'clear' and 'almost clear' to read at task area 2. For both reading task areas the subjects rate the lighting as 'almost comfortable' and 'almost adequate' to read at. The lighting was generally rated to lie between 'satisfying' and 'almost satisfying' for task area 1 and as 'almost satisfying' at task area 2.

For performing the computer task, the light intensity was generally rated as 'just right' on a five point scale from very dim to very bright. Yet, the subjects still rated the lighting to be 'almost satisfying' and 'almost adequate' for performing the computer task. The subjects considered one part of the desk to be dim and the other part to be bright while the lighting was 'almost adequate' to see all objects on the desk and they were 'almost satisfied' with the lighting on the entire desk area.

Data for each of the task lights

The results show that at task area 1 the subjects considered the text as 'clear' to read using all three task lights. At task area 1 the subjects further rate the lighting as 'fully adequate' to read at for TL and as 'almost adequate' to read at for the reference luminaires, the data distribution can be seen in Figure 14. The lighting was rated as 'satisfying' to read at for the TL and RL2 and 'almost satisfying' for RL1.

At task area 2 the text was rated as 'clear' to read when using the TL but for RL1 the text was considered 'almost clear' to read and even less clear for RL2. At task area 2 the TL was rated as providing 'fully adequate' light for reading, while the reference luminaires provided adequate lighting for reading 'to some extent', see Figure 15. The lighting was rated to lie between 'satisfying' and 'almost satisfying' for TL and between 'almost satisfying' and 'satisfying to some extent' for RL1 while RL2 was rated to provide lighting that was between 'almost satisfying' and 'almost dissatisfying'.

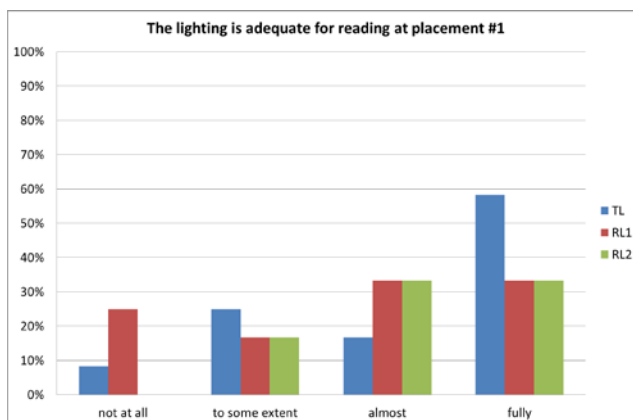


Figure 14. Results on task performance at task area 1.

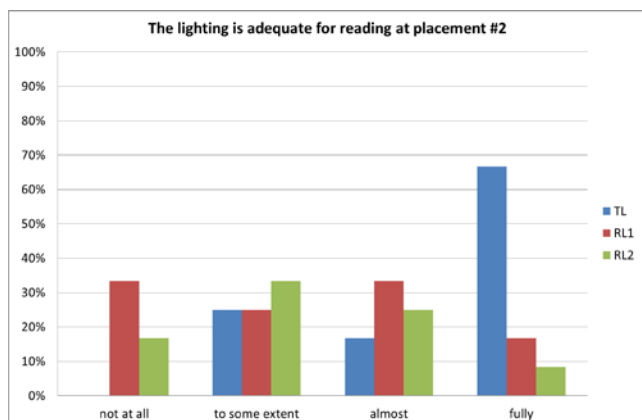


Figure 15. Results on task performance at task area 2.

The light intensity for performing the computer task was rated as 'just right' for TL and RL1 while it was rated as 'dim' for RL2. The lighting was rated as 'almost' adequate for performing the computer task using TL and RL1 and adequate 'to some extent' for RL2, see Figure 16. Using the TL and RL1 the subjects rate the lighting for the computer task to be 'almost satisfying' while they rate it to be between 'almost satisfying' and 'almost dissatisfying' for RL2.

For all three types of luminaires the subjects rate the desk to be partly dim and partly bright and the desk lighting is rated as 'almost satisfying'. TL is the luminaire that provides visual performance of all objects on desk 92 % of the time while the reference luminaires almost do, see Figure 17.

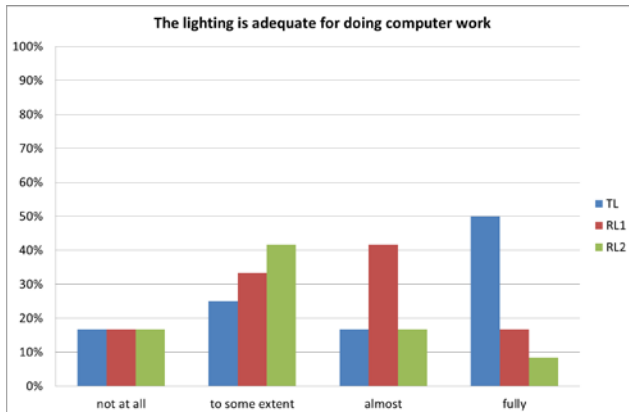


Figure 16. Results on task performance for computer work.

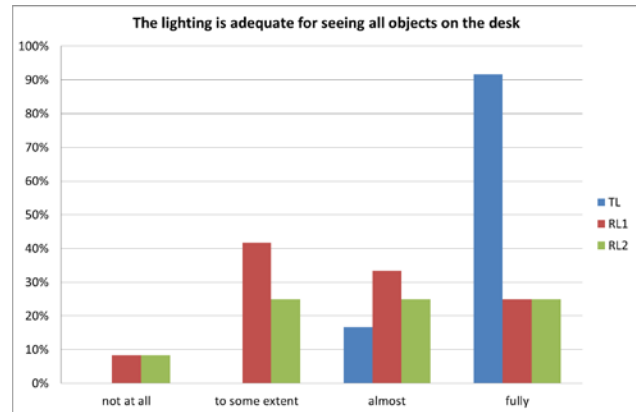


Figure 17. Results on visual performance of objects on desk.

A total of 15 out of 36 subjects experienced glare during the trial. Three subjects experienced glare using RL2 where the source of glare was reported as the task light itself in all cases. Five subjects experienced glare when using RL1, four of them reporting the glare source to be the paper at reading task area 1 and one reported the source to be the task light itself. When using the TL seven subjects reported glare, two reported it to come from the computer screen, two from the paper at reading task area 1 and four from the task light itself. One subject reported noticing flicker from RL1.

Conclusion and Discussion

The results for the complete dataset, including all three types of task lights, show that the data generally is not normally distributed but skewed towards the positive side of the rating scale, indicating that the subjects rate the lighting for their tasks to be more positive than negative. The test luminaire usually rated better for task performance and satisfaction but the results were not statistically significantly different from the reference luminaires.

Glare was identified as a problem for 15 out of 36 subjects. The subjects were asked to adjust the height of the chair to avoid glare but their body posture while performing the tasks still allowed for perception of glare, either directly from the luminaires or as reflected glare from reading tasks (mostly reading task 1 closer to the luminaire) or computer screen, despite the placement of the computer on the opposite side of the desk from the luminaire. For task lights with such a wide light distribution, which are placed on the desk, an important factor to look into is: how to avoid glare on the computer screen.

References

- Akashi, Y., & Boyce, P. R. (2006). A field study of illuminance reduction. *Energy and Buildings*, 38(6), 588–599. doi:10.1016/j.enbuild.2005.09.005
- Bean, A. R., & Hopkins, A. G. (1980). Task and background lighting. *Lighting Research and Technology*, 12(3), 135–139. doi:10.1177/096032718001200303
- BR10, Danish Building Regulations. (2014). 6.5.3 Elektrisk belysning. http://bygningsreglementet.dk/br10_04_id103/0/42.
- CEN, E. (2002). 12464-1: 2002 Light and lighting—Lighting of work places—Part 1: indoor work places. *Brussels, Belgium*.
- Dansk Standard. (2005). *Kunstig belysning i arbejdslokaler (5. udg.)(DS 700: 2005)*.
- Dubois, M.-C., & Blomsterberg, Å. (2011). Energy saving potential and strategies for electric lighting in future North European, low energy office buildings: A literature review. *Energy and Buildings*, 43(10), 2572–2582. doi:10.1016/j.enbuild.2011.07.001
- Horst, R. L., Silverman, E. B., Kershner, R. L., Mahaffey, D. L., & Parris, H. L. (1988). Research study on the effects of illumination on performance of control room tasks. In *Conference Record for 1988 IEEE Fourth Conference on Human Factors and Power Plants*, (pp. 238–246). IEEE. doi:10.1109/HFPP.1988.27510
- Kaye, S. (1988). Variations in the luminous and sonic environment: Proofreading and visual search effects; Mood states and frustration tolerance aftereffects. *New York, NY: Lighting Research Institute*. Retrieved from http://scholar.google.dk/scholar?hl=da&as_sdt=0,5&q=kaye+1988+proofreading#0
- Rea, M., & Ouellette, M. (1991). Relative visual performance: A basis for application. *Lighting Research and Technology*. Retrieved from <http://lrt.sagepub.com/content/23/3/135.short>
- Slater, A. I., & Boyce, P. R. (1990). Illuminance uniformity on desks: Where is the limit? *Lighting Research and Technology*, 22(4), 165–174. doi:10.1177/096032719002200401
- SurveyXact <http://www.surveyxact.dk/> 22.08.2014
- Veitch, J., & Newsham, G. (1996). Determinants of lighting quality II: Research and recommendations. Retrieved from <https://www.nrc-cnrc.gc.ca/obj/irc/doc/pubs/nrcc40343.pdf>

Veitch, J., & Newsham, G. (1998). Lighting quality and energy-efficiency effects on task performance, mood, health, satisfaction, and comfort. *Journal of the Illuminating Engineering* Retrieved from <http://www.tandfonline.com/doi/pdf/10.1080/00994480.1998.10748216>