



Biosensor based on measurements of the clustering dynamics of magnetic particles

Donolato, Marco; Hansen, Mikkel Fougt; Vavassori, Paolo

Publication date:
2014

Document Version
Publisher's PDF, also known as Version of record

[Link back to DTU Orbit](#)

Citation (APA):
Donolato, M., Hansen, M. F., & Vavassori, P. (2014). Biosensor based on measurements of the clustering dynamics of magnetic particles. (Patent No. *WO2014206584*).

General rights

Copyright and moral rights for the publications made accessible in the public portal are retained by the authors and/or other copyright owners and it is a condition of accessing publications that users recognise and abide by the legal requirements associated with these rights.

- Users may download and print one copy of any publication from the public portal for the purpose of private study or research.
- You may not further distribute the material or use it for any profit-making activity or commercial gain
- You may freely distribute the URL identifying the publication in the public portal

If you believe that this document breaches copyright please contact us providing details, and we will remove access to the work immediately and investigate your claim.



- (51) **International Patent Classification:**
G01N 21/17 (2006.01) *G01N 33/543* (2006.01)
- (21) **International Application Number:**
PCT/EP2014/055883
- (22) **International Filing Date:**
24 March 2014 (24.03.2014)
- (25) **Filing Language:** English
- (26) **Publication Language:** English
- (30) **Priority Data:**
13174293.4 28 June 2013 (28.06.2013) EP
- (71) **Applicant:** DANMARKS TEKNISKE UNIVERSITET [DK/DK]; Anker Engeldsvej 1, DK-2800 Kgs. Lyngby (DK).
- (72) **Inventors:** DONOLATO, Marco; Fredericiagade 30, DK-1307 København K (DK). HANSEN, Mikkel Fougte; Weirsøvej 11, Hareskovby, DK-3500 Værløse (DK). VAVASSORI, Paolo; Tolosa Hiribidea 76, E-20018 Donostia, San Sebastian (ES).
- (74) **Agent:** ZACCO DENMARK A/S; Hans Bekkevolds Allé 7, DK-2900 Hellerup (DK).
- (81) **Designated States** (unless otherwise indicated, for every kind of national protection available): AE, AG, AL, AM, AO, AT, AU, AZ, BA, BB, BG, BH, BN, BR, BW, BY, BZ, CA, CH, CL, CN, CO, CR, CU, CZ, DE, DK, DM, DO, DZ, EC, EE, EG, ES, FI, GB, GD, GE, GH, GM, GT, HN, HR, HU, ID, IL, IN, IR, IS, JP, KE, KG, KN, KP, KR, KZ, LA, LC, LK, LR, LS, LT, LU, LY, MA, MD, ME, MG, MK, MN, MW, MX, MY, MZ, NA, NG, NI, NO, NZ, OM, PA, PE, PG, PH, PL, PT, QA, RO, RS, RU, RW, SA, SC, SD, SE, SG, SK, SL, SM, ST, SV, SY, TH, TJ, TM, TN, TR, TT, TZ, UA, UG, US, UZ, VC, VN, ZA, ZM, ZW.
- (84) **Designated States** (unless otherwise indicated, for every kind of regional protection available): ARIPO (BW, GH, GM, KE, LR, LS, MW, MZ, NA, RW, SD, SL, SZ, TZ, UG, ZM, ZW), Eurasian (AM, AZ, BY, KG, KZ, RU, TJ, TM), European (AL, AT, BE, BG, CH, CY, CZ, DE, DK, EE, ES, FI, FR, GB, GR, HR, HU, IE, IS, IT, LT, LU, LV, MC, MK, MT, NL, NO, PL, PT, RO, RS, SE, SI, SK, SM, TR), OAPI (BF, BJ, CF, CG, CI, CM, GA, GN, GQ, GW, KM, ML, MR, NE, SN, TD, TG).
- Published:**
— with international search report (Art. 21(3))

(54) **Title:** BIOSENSOR BASED ON MEASUREMENTS OF THE CLUSTERING DYNAMICS OF MAGNETIC PARTICLES

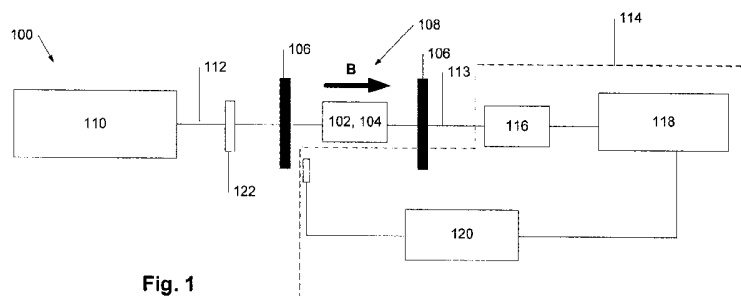

Fig. 1

(57) **Abstract:** Disclosed herein is a biosensor for optical detection of Brownian relaxation dynamics of magnetic particles measured by light transmission. The magnetic particles can be functionalized with biological ligands for the detection of target analytes in a sample.

WO 2014/206584 A1

Biosensor based on measurements of the clustering dynamics of magnetic particles

The invention relates to a novel biosensor adapted for rapid and sensitive detection of target analytes utilizing magnetic nanoparticles.

5

Background

Magnetic nanoparticles and magnetic nanobeads (MNBs), i.e., superparamagnetic nanoparticles embedded in a polymeric matrix, represent a widely spread tool in modern biomedical technologies. In particular their utilization in different biosensing schemes has been explored in the last few years. The long-range interaction between magnetic nanoparticles and an external magnetic field enables easy manipulation and sensitive detection. The main advantages offered by biosensing approaches utilizing magnetic fields and magnetic carriers are that biological media have an intrinsic low magnetic susceptibility and the magnetic interactions are generally not affected by surface charges, pH values, ionic concentrations or temperature. In addition, the realization of a microfluidic device based on magnetic carriers to capture, sort and detect target analytes in biological media is particularly appealing, due to the potential low-cost, simplicity of the device and high sensitivity achievable.

20

US7639359 discloses a method for detection of analytes by measuring single particle dynamics of bio-functionalized magnetic nanoparticles. The method in US7639359 comprises applying linearly polarized light to a suspension of bio-functionalized nanoparticles subjected to an oscillating magnetic field and subsequently measure how the polarization of the light rotates when passing through the magnetic nanoparticles suspension. In this case the signal monitored is in the first harmonic signal with respect to the magnetic field excitation.

30

One disadvantage with the method disclosed in US7639359 is that it is complex, it relies on a very small signal due to light polarization rotation and consequently the setup is costly in that it requires optical elements such as aligned polarizers in order to ensure that the rotation of the light polarization is correctly measured. Another disadvantage with the method disclosed in US7639359 is that it requires single

domain magnetic nanoparticles in order to work that these are generally not efficient light scatters.

5 US20120003750 discloses a method for detection of an analyte by measuring dynamics of analyte-driven cluster formation of bio-functionalized superparamagnetic particles. The method in US20120003750 comprises allowing the superparamagnetic particles in a suspension to form analyte-driven clusters in the presence of a rotating magnetic field and thereafter measure the intensity and amplitude of the scattered light at higher harmonics of the driving frequency.

10

One disadvantage of the method disclosed in US20120003750 is the requirement of electromagnets creating a rotating in-plane magnetic field. Having electromagnets generating a rotating field will take up more space thus limiting practical implications such down-sizing of the biosensing setup or integration of the setup into other systems. In addition the signal due to scattered light from magnetic beads at a large angle from the incident light is extremely low, especially for particles of few hundreds nm of diameter, and a large area and very sensitive photodetector or photomultiplier is needed.

20 **Description of the invention**

Disclosed herein is a biosensor comprising a suspension of magnetic particles and an optical reservoir containing the suspension of magnetic particles. The optical reservoir may be a cuvette or similar.

25 The biosensor also comprises a light source emitting light at a wavelength λ with an intensity I , the light source being directed at the optical reservoir and being adapted for interacting with the suspension of magnetic particles, where the light entering the optical reservoir has an intensity I_{in} and light transmitted through the optical reservoir has an intensity I_{trans} . The light source may be a laser emitting light in e.g. the ultra violet (UV), visible or infrared (IR) spectral area, a UV lamp, a light emitting diode (LED) or similar.

30

The biosensor also comprises a magnetic field generation unit generating an oscillating uniaxial magnetic field oscillating at a frequency f_x being variable between

a start frequency $f_{x, \text{start}}$ and an end frequency $f_{x, \text{end}}$, the oscillating uniaxial magnetic field being applied to the optical reservoir containing the suspension of magnetic particles whereby the suspension of magnetic particles is modulated such that the intensity I_{trans} of light transmitted through the suspension of magnetic particles is
5 modulated compared to the intensity I_{in} of the light entering the optical reservoir.

The biosensor further comprises a detection unit measuring the intensity I_{trans} of the light transmitted through the suspension of magnetic particles in the optical reservoir wherein the modulation of the intensity I_{trans} of the transmitted light is detected at a
10 frequency f_y varying between a start frequency $f_{y, \text{start}}$ and an end frequency $f_{y, \text{end}}$ as the oscillating uniaxial magnetic field is swept from the start frequency $f_{x, \text{start}}$ to the end frequency $f_{x, \text{end}}$, wherein the detected frequency f_y is different from the first harmonic component f_x .

15 The biosensor is primarily for measuring the dynamic clustering behaviour of magnetic particles driven by the oscillating uniaxial magnetic field. Alternatively, the biosensor can also be used for time-resolved measurements of the particle cluster break-up/reformation after/upon application of an external magnetic field.

20 A simple, flexible and inexpensive biosensor is thereby obtained in that only a few elements are required and there is a variety of options for exchanging individual parts in the setup. Importantly any kind of light source can be introduced into the system that does not require linearly polarized light, laser light sources or polarizers that per definition will increase both complexity and cost of the biosensor.

25 The oscillating uniaxial magnetic field used in the biosensor is beneficial in that it lowers the overall space requirements making the biosensor suitable for implementation into a variety of devices. By measuring the modulation in the intensity I_{trans} of the light transmitted through the suspension of magnetic particles,
30 and not the polarization change of the light, it is possible to record measurements even after the light has been transmitted through the sample multiple times further increasing the flexibility of the biosensor.

In one or more embodiments the second harmonic ($f_y = 2f_x$) or higher harmonic components of the intensity I_{trans} of the transmitted light is detected by the detection unit.

- 5 In one or more embodiments the magnetic particles are functionalized with a bioactive ligand, such as e.g. antibodies, DNA, RNA, peptides, proteins, or protein complexes. The bioactive ligand is able to bind to/capture target/analyte molecules in a sample to be analysed, whereby the existence of this target/analyte is easily detectable. The term target/analyte molecules also includes cells or bacteria.

10

In one or more embodiments the magnetic particles have a non-zero remnant magnetic moment. This enables the physical rotation of individual particles and aids in breaking up ordered particles ensembles, e.g. chains.

- 15 In one or more embodiments the magnetic particles are present in a suspension concentration in the range of 0.1 $\mu\text{g/mL}$ to 2000 $\mu\text{g/mL}$. Alternatively, the suspension concentration can be in the range of 0.1 $\mu\text{g/mL}$ to 500 $\mu\text{g/mL}$, or in the range of 0.1 $\mu\text{g/mL}$ to 50 $\mu\text{g/mL}$.

- 20 In one or more embodiments the magnetic particles are magnetic beads, such as e.g. magnetic polymeric beads. The magnetic particles can be substantially spherical, in the sense that individual particles have negligible optical anisotropy along the applied oscillating uniaxial magnetic field. Alternatively, the magnetic particles can have a more irregular shape, but still with a negligible optical

- 25 anisotropy of an ensemble of individual particles applied oscillating uniaxial magnetic field. In one or more embodiments the substantially spherical magnetic particles have a diameter between 10 and 3000nm. The particles may also be between 20 and 1000 nm or between 50 and 250 nm.

- 30 In one or more embodiments the magnetic field generation unit is an electromagnet generating a time varying magnetic field between $f_{x, \text{start}} = 0.1 \text{ Hz}$ and $f_{x, \text{end}} = 10 \text{ kHz}$, the magnetic field having a magnetic field intensity between 0.1 mT and 5 mT

In one or more embodiments the light source is a UV lamp, a light emitting diode (LED), a laser emitting light in e.g. the ultra violet (UV), visible or infrared (IR) spectral range or similar.

5 In one or more embodiments the emitted light is linearly polarized.

In one or more embodiments, the biosensor further comprises a polarizer positioned between the light source and the optical reservoir. Controlling the polarization of the light can be employed to enhance the signal.

10

In one or more embodiments, the biosensor further comprises at least one reflecting object positioned such that the light being transmitted through and being modulated by the suspension of magnetic particles in the optical reservoir, and/or the light transmitted through the optical reservoir not being modulated by the suspension of
15 magnetic particles, is reflected back through the optical reservoir by the reflecting object. The light is thereby allowed to pass through the optical reservoir twice. This is advantageous in that the detection unit and the light source can be integrated into one unit in this way thereby reducing space for the biosensor.

20 In one or more embodiments the light source and the detection unit are integrated into an optical pickup head, e.g. from a CD player, a DVD player or a Blu-ray.

In one or more embodiments the biosensor is used for diagnostic purposes. These uses may be e.g. by for analyzing blood, saliva, urine, water, plasma, or serum.

25

In one or more embodiments one or more types of particles are mixed together. The different types of particles can have different sizes, different properties such as being either magnetic or non-magnetic, or in case the particles are magnetic they can have different magnetic susceptibilities.

30

In one or more embodiments magnetic particles can be functionalized with or incorporate a fluorescent dye.

Disclosed herein is also a method for detecting magnetic particle dynamics by light transmission using a biosensor according to the above. The method comprising the steps of:

- 5 - mixing a sample fluid to be analyzed with a suspension of magnetic particles in an optical reservoir;
- directing a light source emitting light at a wavelength λ with an intensity I through the optical reservoir;
- providing an uniaxial magnetic field oscillating at a frequency f_x ;
- applying the uniaxial magnetic field to the optical reservoir whereby the
10 suspension of magnetic particles is modulated such that the intensity I_{trans} of light transmitted through the suspension of magnetic particles is modulated compared to the intensity I_{in} of the light entering the optical reservoir;
- sweeping the uniaxial magnetic field from a starting frequency $f_{x, start}$ to an end frequency $f_{x, end}$; and
- 15 - measuring the intensity I_{trans} of the light transmitted through the suspension of magnetic particles in the optical reservoir at a frequency f_y varying between a start frequency $f_{y, start}$ and an end frequency $f_{y, end}$ as the uniaxial magnetic field is swept from the start frequency $f_{x, start}$ to the end frequency $f_{x, end}$, the frequency f_y being different from the first harmonic component f_x .

20

Thereby the biosensor can also be used for time-resolved measurements of the particles relaxation after the application of the magnetic field.

25 In one or more embodiments second harmonic ($f_y = 2f_x$) or higher harmonic components of the intensity I_{trans} of the transmitted light is measured.

In one or more embodiments the uniaxial magnetic field is swept from a start frequency of $f_{x, start} = 0.1$ Hz to an end frequency of $f_{x, end} = 10$ kHz.

30 The detection scheme used in the measurements may include a variation of the wavelength of the light from the light source and/or a switching on/off of the light and/or a modulation of the magnetic field at, where the signal, which is detected, is at an integer combination of the frequency of the modulation of the light from the light source and the frequency of the magnetic field.

Detection of the target molecule/cell/bacteria can be achieved by measuring the increase of the hydrodynamic diameter of the particles when the target molecule binds on the specifically functionalized particle surface.

5

Detection of the target molecule/cell/bacteria can also be achieved by target molecule induced aggregate formation of specifically functionalized magnetic particles of the same type (i.e. agglutination assay).

10 Further, detection of the target molecule/cell/bacteria may be achieved by target molecule induced aggregate formation of specifically functionalized particles of different types such as magnetic/nonmagnetic, particles of different sizes or particles having fluorescent dyes on the surface or incorporated within the particles.

15 These are three of the most general way one can use this system as a biosensor.

Brief description of the drawings

Figure 1 illustrates a biosensor setup.

20 Figures 2a-b show two different measurement configurations.

Figure 3a show the temporal variation of the transmitted light in the measurement configuration of figure 2a and figure 3b shows the Fast Fourier Transform (FFT) of the photodetector signal using the setup of figure 2a.

25

Figure 4 illustrates a frequency sweep measured in the measurement configuration of figure 2a.

30 Figures 5a-c show in-phase and out-of phase 2nd harmonic signals recorded for a suspension of magnetic beads at different measurement configurations.

Figure 6 shows the dependence on the particle concentration suspension for the in-phase 2nd harmonic signal.

Figure 7 shows the dependence on the magnetic field amplitude for the in-phase 2nd harmonic signal.

5 Figure 8 shows the dependence on the particle size for the in-phase 2nd harmonic signal.

Figure 9a shows in-phase 2nd harmonic signals recorded for suspensions of streptavidin magnetic beads mixed with different concentrations of biotinylated BSA.

10 Figure 9b shows in-phase 2nd harmonic signals recorded for suspensions of streptavidin magnetic beads mixed with different concentrations of biotinylated antibody.

15 Figures 10a-b show a modified version of the biosensor with figure 10b being a close-up of the optical reservoir in shown in figure 10a.

Figure 11 shows a disc with embedded optical reservoirs.

Description of preferred embodiments

20 Figure 1 shows an embodiment of the biosensor 100 for detection of analytes. The detection principle is based on measurements of the dynamic behaviour of magnetic nanoparticles driven by an oscillating uniaxial magnetic field by measuring the intensity I_{trans} of the light transmitted through the suspension of nanoparticles. Alternatively, the biosensor can also be used for time-resolved measurements of the
25 particles relaxation after the application of the magnetic field.

Detection of the target molecule/cell/bacteria can be achieved by measuring the increase of the hydrodynamic diameter of the particles when the target molecule binds on the specifically functionalized particle surface.

30 Detection of the target molecule/cell/bacteria can also be achieved by target molecule induced aggregates formation of specifically functionalized magnetic particles of the same type (i.e. agglutination assay).

Further, detection of the target molecule/cell/bacteria may be achieved by target molecule induced aggregate formation of specifically functionalized particles of different types such as magnetic/nonmagnetic, particles of different sizes or by having fluorescent dyes on the surface.

5

These are three of the most general way one can use this system as a biosensor

The biosensor 100 comprises a suspension of magnetic particles 102 in an optical reservoir 104. The magnetic particles suspended in the solution 102 may be
10 substantially spherical particles, in the sense that individual particles have negligible optical anisotropy. Alternative shapes such as e.g. ellipsoidal or ovoid-shaped particles (irregular-shaped) can also be used. The magnetic particles may also be magnetic beads such as magnetic polymeric beads.

15 The suspension of magnetic particles may include more than one type of particles mixed together. The different types of particles can have different sizes, or different properties such as being either magnetic or non-magnetic (as long as one of the particles types is magnetic). In case the particles are all magnetic particles they can have different magnetic susceptibilities. The sizes of the individual particles types
20 may vary from being nano-sized particles to being micron-sized particles. The use of bigger particles can block the rotation of smaller particles if a target molecule is present.

The magnetic particles may be functionalized with a bioactive ligand, such as e.g.
25 antibodies, DNA, RNA, peptides, proteins, or protein complexes. The magnetic particles may also be functionalized with a fluorescent dye.

The magnetic particles will normally have a non-zero remnant magnetic moment.

30 The optical reservoir 104 is illustrated as a cuvette in figure 1 but alternatives such as different forms of microfluidic devices could also be imagined. A microfluidic system comprising microcapillary valves, microneedle for injection, dilution and mixing of the sample to be analyzed and similar could also be used in combination with the optical reservoirs.

The biosensor 100 comprises a magnetic field generation unit 106 generating a
oscillating uniaxial magnetic field 108. The oscillating uniaxial magnetic field 108 is
applied to the optical reservoir 104 containing the suspension of magnetic particles
5 102 as illustrated in figure 1. The magnetic field generation unit can e.g. be an
electromagnet generating an AC magnetic field having a magnetic field intensity.
The frequency of the AC magnetic field will normally be between 0.1 Hz and 10 kHz.
The magnetic field intensity will normally be between 0.1 mT and 5 mT.

10 The biosensor also comprises a light source 110 directed at the optical reservoir
104. The light 112 from the light source 110 is adapted for interacting with the
suspension of magnetic particles 102. The light source could be a laser emitting light
in e.g. the ultra violet (UV), visible or infrared (IR) spectral range, a UV lamp, a light
emitting diode (LED) or similar. The emitted light will normally be linearly polarized
15 when exiting the light source.

Normally, a light source 110 will emit light at a wavelength λ with an intensity I . The
light entering the optical reservoir 104 will have an intensity I_{in} and light transmitted
through the optical reservoir will have an intensity I_{trans} . The magnetic field
20 generation unit 106 will normally generate an oscillating uniaxial magnetic field
oscillating at a frequency f_x being variable between a start frequency $f_{x, start}$ and an
end frequency $f_{x, end}$.

In figure 1, the light 112 from the light source 110 and the oscillating uniaxial
25 magnetic field 108 from the magnetic field generation unit 106 propagate parallel
with each other towards the optical reservoir 104. Figure 2a shows this
measurement setup in a close-up view. Alternatively, a perpendicular measurement
configuration could also be imaging as shown in figure 2b.

30 The biosensor 100 in figure 1 further comprises a detection unit 114 measuring
components of the frequency f_y of the transmitted light being different from the first
harmonic component f_x . These frequencies could be the 2nd or higher harmonic
components of light 113 transmitted from the suspension of magnetic particles 102
in the optical reservoir 104. Normally, the frequency f_y varying between a start

frequency $f_{y, \text{start}}$ and an end frequency $f_{y, \text{end}}$ as the oscillating uniaxial magnetic field is swept from the start frequency $f_{x, \text{start}}$ to the end frequency $f_{x, \text{end}}$ will be detected.

5 In figure 1, the detection unit 114 comprises a photodiode 116, a lock-in amplifier 118, and a gauss meter 120. Different detection units could also be used without changing the scope of this invention. A polarizer may also be positioned between the light source and the optical reservoir.

10 The light source 110 used for producing the experimental data described and shown in the subsequent figures are obtained using a COHERENT laser emitting light with a wavelength of $\lambda = 633$ nm. The signals are likewise collected by a ThorLabs PDA36A photodetector while the beam is expanded to a final diameter of 5 mm with an adjustable LINOS beam expander (not shown in the figure). The magnetic field is measured real time with a Hall-probe (not shown in the drawing).

15 The self-inductance of the magnetic coils used was corrected for to maintain a constant field amplitude vs frequency. The signal was filtered using a Signal Recovery 7225 computer controlled lock-in amplifier. The dynamic light scattering measurements were performed with a Malvern Zetasizer Nano device.

20 When a magnetic field is applied to a suspension of magnetic particles, an optical anisotropy is induced in the medium due to the formation of linear chains of particles aligned with the field. This anisotropy leads to the phenomena of linear dichroism, i.e., different attenuation of the transmitted light for different polarization components of the light due to different adsorption and/or scattering. The formation dynamics of linear chains is dominated by the Brownian rotation of the particles and this can be
25 sensed by light transmission/scattering.

30 The present method relies on the dynamic breaking and reforming of particles clusters and the formation of permanent clusters in the presence of biomolecular recognition. This approach is fundamentally different from the rotation dynamics of the clusters presented in US20120003750. There, the equilibrium cluster size (which is constant over a field cycle) in a rotating magnetic field gives a modulation of the scattered light. Typically, magnetic beads with a non-zero remnant moment is used

for these measurements. In the approach, disclosed in this application, clusters are dynamically disrupted and reformed during a cycle of the axially varying magnetic field resulting in a modulation of the transmitted optical signal. Thus, the signal in the present approach is given by the ability of the individual particles to align with the axial magnetic field and reform magnetic chains and this is typically done with particles with a remnant magnetic moment. The dynamics of these magnetic nanoparticles is governed by their ability to align their remnant magnetic moment by a physical rotation of the individual particles (Brownian rotation) and to reform the particle clusters. The Brownian relaxation frequency is characterized by:

10

$$f_B = \frac{k_B T}{6\pi\eta V_h} \quad \text{Eq. 1}$$

where k_B is the Boltzmann's constant, T is the absolute temperature, V_h is the hydrodynamic particle volume and η is the dynamical viscosity of the fluid.

15

Upon excitation by a weak alternating magnetic field (with $H_{AC}(t) = H_0 \sin(2\pi ft)$), the magnetization $m(t)$ of e.g. magnetic nanoparticles change due to their physical rotation. In the time domain, the magnetization can be written as

$$m(t) = m_{AC} \sin(\omega t - \phi) \quad \text{Eq. 2}$$

where ϕ is the phase lag between the magnetization response and the excitation and m_{AC} is the frequency dependent amplitude of the magnetization.

25 In the frequency domain, the magnetic nanoparticles response is characterized by the complex magnetic susceptibility:

$$\chi = \chi' - i\chi'' = |\chi|(\cos\phi - i \sin\phi) \quad \text{Eq. 3}$$

30 with in-phase component χ' and out-of-phase component χ'' . At low frequencies, the magnetization of the magnetic nanoparticles responds in-phase with the applied

magnetic field ($\phi = 0$). Upon increasing the frequency, the magnetic nanoparticles magnetization will lag behind the applied field and χ' will decrease monotonically. Correspondingly, χ'' first increases to assume its maximum value when $f = f_B$ and decreases above f_B .

5

The magnetic susceptibility of a bead ensemble is well described by

$$\chi = \chi' - i\chi'' = \frac{\chi_0 - \chi_\infty}{1 + (if/f_B)^{1-\alpha}} + \chi_\infty \quad \text{Eq. 4}$$

10 where χ_0 and χ_∞ are the magnetic susceptibilities for $f = 0$ and $f = \infty$, respectively, and α is a parameter accounting for polydispersity ($\alpha = 0$ for a monodisperse ensemble of magnetic nanoparticles).

The normalized magnetic susceptibility is defined by

15

$$\tilde{\chi} = \chi/\chi_0 = \tilde{\chi}' - i\tilde{\chi}'' = |\tilde{\chi}|(\cos\phi - i\sin\phi) \quad \text{Eq. 5}$$

which fulfills that $\tilde{\chi}(0) = 1$ and $\tilde{\chi}(\infty) = \chi_\infty/\chi_0$.

20 Sufficiently small or weakly magnetic interacting magnetic nanoparticles with negligible optical anisotropy of the individual particles show no significant agglomeration in zero applied magnetic field indicating that the thermal energy is larger than the magnetic interaction energy due to the remnant moment. Consequently, the light transmitted by the solution of nanoparticles will show
 25 negligible optical anisotropy when no magnetic field and/or analyte is present. Magnetic nanobeads are examples of magnetic nanoparticles showing negligible optical anisotropy when they are not clustered.

In the measurement configuration shown in figure 2a, the oscillating uniaxial
 30 magnetic field 108 is applied parallel to light 112 from the light source 110 – in this

figure being a laser beam – propagation direction. This configuration will be denoted $\mathbf{B} \parallel \mathbf{k}$ in the following.

- 5 For the majority of particle sizes, the transmitted signal for the $\mathbf{B} \parallel \mathbf{k}$ configuration is maximal when the field is large, which is consistent with the fact that chains are formed along the light path that decrease the geometrical cross-section of the suspension. When the magnetic field approaches zero after positive saturation, the chains break up or become loosely bound due to thermal agitation.
- 10 When the field changes sign, the particles have to rotate physically to align their remnant magnetic moments with the field. When the Zeeman energy of a single magnetic nanoparticle is larger than the interaction energy with its neighbors, this will result in a rotation of the individual particles rather than a rotation of chains of particles. In this case, the observed dynamics therefore consists of (1) disruption of
- 15 magnetic nanoparticle chains due to thermal agitation and/or the sign change of the magnetic field, (2) rotation of the individual magnetic nanoparticles trying to align with the magnetic field, and (3) reformation of magnetic nanoparticle chains. Hence, the time scale for the diffusion and rotation of the individual magnetic nanoparticles sets the time scale for the reforming of magnetic nanoparticle chains that give rise to
- 20 the modulation of the optical signal.

In another measurement configuration as shown in figure 2b, the uniaxial magnetic field 108 is applied perpendicular to light 112 from the light source 110 – in this figure being a laser beam – propagation direction. This configuration will be denoted

25 $(\mathbf{B} \perp \mathbf{k})$ in the following.

When the oscillating magnetic field is applied perpendicular to the laser beam direction $(\mathbf{B} \perp \mathbf{k})$ a polarizer 122 is introduced in the optical beam between the laser and the optical reservoir containing the particles to define a linear polarization at an

30 angle θ to the magnetic field direction, where the angle θ with the x- axis is as sketched in the lower right part of figure 2b.

The optical signal that is symmetric with respect to the magnetization orientation of a chain may in a simple manner be explained by:

$$V(t) = V_{\text{offset}} + V_{\text{AC}} \sin^2(\omega t - \phi) \quad \text{Eq. 6}$$

where V_{AC} is the frequency-dependent amplitude of the signal modulation, V_{offset} is
 5 the signal offset and where we have neglected possible higher order terms of even
 powers of $\sin(\omega t - \phi)$. V_{AC} has the same frequency dependence as the magnetic
 susceptibility, such that

$$V_{\text{AC}} = V_0 |\tilde{\chi}| \quad \text{Eq. 7}$$

10

where V_0 is the amplitude for $f \rightarrow 0$. By recording the 2nd harmonic component of the
 signal by the light transmitted in the magnetic nanobead suspension, it is possible to
 precisely record and distinguish the frequency response of magnetic nanobeads
 having diameters of 50 nm, 130 nm and 250 nm. This is showed and discussed
 15 further in figure 8.

The 2nd harmonic signal

$$V_2 = V_2' + iV_2'' \quad \text{Eq. 8}$$

20

is measured by lock-in technique to be

$$\begin{aligned} V_2' &= -\frac{1}{2\sqrt{2}} (V_0 |\tilde{\chi}|)^2 \sin(2\phi) = -\frac{1}{\sqrt{2}} V_0^2 (\tilde{\chi}')(\tilde{\chi}'') \\ V_2'' &= -\frac{1}{2\sqrt{2}} (V_0 |\tilde{\chi}|)^2 \cos(2\phi) = -\frac{1}{2\sqrt{2}} V_0^2 [(\tilde{\chi}')^2 - (\tilde{\chi}'')^2] \end{aligned} \quad \text{Eq. 9}$$

25 Figure 3a shows the temporal variation 200 of the transmitted light in configuration
B \parallel **k** for a suspension of magnetic nanobeads with a size of 50 nm in diameter and
 a concentration of 10 μg MNB/mL suspension. Line 202 indicates the oscillating
 external magnetic field waveform, while line 204 and line 206 represent the
 measured AC component of the photodetector signal under or in absence of the
 30 oscillating magnetic field.

The applied field has an amplitude of 1 mT and $f = 5$ Hz. In the figure is sketched the position of the magnetic bead clusters along the z-direction in the field maxima region.

5

In figure 3a the measurement configuration comprises a laser source ($\lambda = 633$ nm), a transparent circular fluidic cell having diameter 5 mm and height, corresponding to the optical path in the liquid, of 1 mm. The cell, which has a volume of roughly 20 μL , is surrounded by two miniaturized electromagnets for generating the AC
10 magnetic field and a photo detector. The optical cell may also be a cuvette or a microfluidic device.

The laser spot size can be expanded up to ~ 5 mm diameter by means of an adjustable beam expander in order to interact with the largest possible number of
15 particles. In both cases, the amplitude of the applied magnetic field ranges between 1 and 3 mT. The AC magnetic field is measured in real time using a high-speed Hall probe that also provides the reference for a lock-in amplifier used to filter and detect the 2nd harmonic voltage output from the photo detector in-phase and out-of-phase with the AC driving field. In an embodiment the frequency of the AC field is between
20 0.1 Hz and 10 kHz and the magnetic field has an intensity between 0.1 mT and 5 mT.

In the measurements described in the following, the optical effect which is measured due to the formation of magnetic particle chains in suspension can have a different
25 sign. This depends on whether more or less light is transmitted when the field is maximum with respect to when it is zero again depending on the bead size, bead clustering state and/or the wavelength of the light used. This is discussed further in figure 9b.

30 In figure 3a, the signal level for the measurements obtained with no magnetic field excitation, line 206, is the same before and after an experiment. The signal with the field excitation, line 204, is dominated by a component at $2f$, and shows sharp minima when the applied field intensity is close to zero and maxima when the field is

numerically large. The signal level of the minima is close to that obtained when no magnetic field excitation is applied.

Figure 3b shows the Fast Fourier Transform (FFT) 300 of the same photodetector
5 signal as in figure 3a. Figure 3b confirms the results from figure 3 in that the signal is dominated by a $2f$ component at 10 Hz, although weaker higher order even harmonics are also present.

Figure 4 shows the frequency sweep 400 measured in the configuration $\mathbf{B} \parallel \mathbf{k}$ for
10 the suspension of MNBs of 50 nm diameter and concentration 50 $\mu\text{g/mL}$. Figure 4 illustrates the complex 2^{nd} harmonic signal 400 measured by lock-in technique vs. frequency of the applied magnetic field. The measured in-phase signal (V_2') 402 has a clear peak near about 100 Hz whereas the out-of-phase signal (V_2'') 404 shows a step-like transition with saturation at low frequencies and a value close to zero at
15 high frequencies. The solid lines 412, 414 indicates the fits of the curve for the in-phase signal (V_2' signal) 402 and the out-of phase signal (V_2'' signal) 404 using the Eq.(9).

Figure 5a and 5b show a comparison of the data collected on the same MNBs
20 suspension using different experimental configurations with the V_2' signal 500 and the V_2'' signal 510 displayed in figure 5a and 5b, respectively. The data are recorded for a suspension of 50 nm magnetic beads at a concentration 10 $\mu\text{g/mL}$.

The signals are measured at four different measurement configurations; lines 502
25 and 512 are measured with the configuration $\mathbf{B} \parallel \mathbf{k}$, lines 504 and 514 with the configuration $\mathbf{B} \perp \mathbf{k}$ and $\theta = 0^\circ$, lines 506 and 516 with the configuration $\mathbf{B} \perp \mathbf{k}$ and $\theta = 90^\circ$, and lines 508 and 518 with the configuration $\mathbf{B} \perp \mathbf{k}$ using a circularly polarized beam. All the lines have been normalized to the total intensity of the beam I_0 . The angle θ is the angle sketched in figure 2b which is defined as the angle between the
30 laser beam polarization and the \mathbf{B} field axis directions.

Although the spectra in the $\mathbf{B} \parallel \mathbf{k}$ configuration 502, 512 just discussed have been collected using a linearly polarized laser, they do not depend on the particular polarization state of the beam (they are only due to the transversal nature of the

electromagnetic waves) and one would expect to obtain the same results using for instance a completely depolarized source.

The hypothesis was checked using a circularly polarized beam, obtained through
5 the insertion of a quarter ($\pi/4$) retarder in the optical path preceding the optical reservoir (principal axes of the retarder at 45° with respect to the polarization direction of the beam generated by the laser source). The results of these measurements are indeed identical to those in figure 5a as shown in figure 5c, where the in-phase V_2' signal measured with a $\mathbf{B} \parallel \mathbf{k}$ and $\theta = 90^\circ$ configuration is
10 displayed as line 520 and in-phase V_2' signal measured with a $\mathbf{B} \parallel \mathbf{k}$ and circular polarization configuration is displayed as line 522.

For side-to-side comparison of the spectra, data are normalized to the average intensity I_0 of the transmitted beam. If the laser beam is linearly polarized
15 perpendicular to the applied AC field direction, $\mathbf{B} \perp \mathbf{k}$ and $\theta = 90^\circ$, the signal show the same features as for the configuration $\mathbf{B} \parallel \mathbf{k}$ discussed above since more light is transmitted when the chains are aligned with the AC field that is perpendicular to the polarization direction. Conversely, using a light beam linearly polarized parallel to the applied field, namely $\mathbf{B} \perp \mathbf{k}$ and $\theta = 0^\circ$, the light scattering mechanism is
20 maximized by aligning, at high field, the long axis of the MNBs formed chains parallel to the electric field of the laser beam and, thus, to achieve a better signal contrast. As a confirmation of the dichroic effect, meaning that different light polarization components are differently scattered, if a circularly polarized light beam is used, a lower signal, but having the same sign of the $\theta = 0^\circ$ can be recorded
25 ($\mathbf{B} \perp \mathbf{k}$, unpolarized spectra in figure 5a).

Figure 6 shows V_2' signal 600 recorded for a suspension of 50 nm magnetic beads for different suspension concentration ranging from 1 $\mu\text{g/mL}$ to 10 $\mu\text{g/mL}$ measured in the configuration of $\mathbf{B} \perp \mathbf{k}$ and $\theta = 0^\circ$ (thus a similar configuration as lines 502,
30 512 in figures 6a-b) for an applied field of 2 mT. Line 602 represents a concentration of 1 $\mu\text{g/mL}$, line 604 a concentration of 2 $\mu\text{g/mL}$, line 606 a concentration of 5 $\mu\text{g/mL}$, and line 608 a concentration of 10 $\mu\text{g/mL}$. The magnetic nanoparticles may also be present in a concentration range of 0.1 $\mu\text{g/mL}$ to 2000 $\mu\text{g/mL}$. Alternatively,

the suspension concentration can be in the range of 0.1 $\mu\text{g/mL}$ to 500 $\mu\text{g/mL}$, or in the range of 0.1 $\mu\text{g/mL}$ to 50 $\mu\text{g/mL}$.

Figure 7 shows V_2' signal 700 recorded for 50 nm magnetic beads in a concentration 10 $\mu\text{g/mL}$ for different values of the applied field amplitude ranging from 1 mT to 3 mT with line 702 representing an applied field amplitude of 1 mT, line 704 representing an applied field amplitude of 1.5 mT, line 706 representing an applied field amplitude of 2 mT, line 708 representing an applied field amplitude of 2.5 mT, and line 710 representing an applied field amplitude of 3 mT.

10

The V_2' spectra in figure 7 show that, for the same MNBs suspension, the peak frequency value and the signal intensity increase with the amplitude of the AC field.

Figure 8 shows the comparison of the V_2' spectra recorded in a measurement configuration $\mathbf{B} \perp \mathbf{k}$ with $\theta = 0^\circ$ with varying size of the beads while keeping their concentration constant at 10 $\mu\text{g/mL}$ as well as the amplitude of 2 mT of the AC field.

Line 802 is obtained with particles having a size of 50 nm, line 804 is obtained with particles having a size of 130 nm, and line 806 is obtained with particles having a size of 250 nm. For sake of clarity, the spectra have been normalized to their maximum value. The three MNB types show a similar behavior and three distinct value of f_B , being 21 Hz, 141 Hz and 233 Hz for particles having a size of 50 nm (line 802), 130 nm (line 804), and 250 nm (line 806), respectively.

25 In general the magnetic particles may have a diameter between 10 and 3000 nm, or between 20 and 1000 nm or between 50 and 250 nm.

A calculation of the average hydrodynamic diameter using Eq.(1) (for equivalent spheres at 300 K) gives hydrodynamic sizes of 122 nm (for the 50 nm MNBs), 144 nm (for the 130 nm MNBs) and 271 nm (250 nm MNBs). Dynamic light scattering measurements on the very same bead suspensions indicate a mean measured diameter for the beads of 114 nm, 126 nm and 250 nm (data not shown here).

30

- By monitoring f_B it is possible to precisely characterize the mean hydrodynamic volume of the rotating MNB cluster suspension. In addition, by measuring the suspension under an applied field of 2 mT, the V_2' component of the spectra peaks at a frequency value nearly correspondent to the one expected from the χ' spectra
- 5 from Eq. (1). This theoretical description is valid for MNBs having a remnant magnetic moment, while the behavior of completely superparamagnetic MNBs having similar sizes differs since the individual MNBs may not be subjected to Brownian relaxation
- 10 To test the sensitivity of the setup in presence of a biological analyte, changes in the spectra were recorded when the formation of clusters was induced inside the MNBs suspension in presence of biotinylated bovine serum albumin. These results are shown for the in-phase 2nd harmonic component in figure 9a. The data is obtained in a configuration where the magnetic field are propagating perpendicularly to the light,
- 15 i.e. the detection configuration of figure 2b. A 20 μ l suspension of 0.5mg/ml Streptavidin coated Micromod Starch particles, having a nominal diameter of 80 nm, mixed with 20 μ l sample containing different concentrations of biotinylated bovine serum albumin are shown in the figure. The samples have been left incubating for
- 20 separator until all particles were collected at the side of the tube. Particles were kept there in order to induce cluster formation. Finally, the suspension have been diluted to a total volume of 200 μ l and measured. Suspensions of 80 nm (50 μ g/mL) MNBS mixed with different concentrations of biotinylated BSA (bBSA) are obtained and the V_2' signals 900 are measured after inducing MNB clustering with an external
- 25 magnet. The signal is measured using blue light laser having a wavelength of 450 nm. The lines 902, 904, 906, 908, 910, and 912 represents a biotinylated BSA concentration of 0 pM, 100 pM, 250 pM, 500 pM, 1000 pM, and 2000 pM, respectively.
- 30 Figure 9b shows the in-phase component for biotinylated antibody detection using the configuration of figure 2a with a light beam propagating in parallel with the magnetic field. The blank signal shows a single peak, due to free magnetic beads rotating in suspension. When beads form clusters, an extra peak with opposite sign appears in the low frequency range of the spectra. This is due to clustered beads,

which have opposite optical response to the external magnetic field excitation with respect to free beads. The light modulation created by the chain formation disruption dynamics of free beads have an opposite sign to the one of clustered beads, since they have a different Mie's scattering cross section at 405 nm wavelength. As can
5 be seen in figure 9b, the low-frequency peak having a positive sign increases in intensity as the concentration of the antibody increases until the concentration becomes quite large.

Thus, the data shown in figure 9b shows a strong increase in the sensitivity of the
10 method as single and clustered beads can be easily distinguished and quantified.

For these measurements a blue light laser emitting at a wavelength of 450 nm is used in order to amplify the scattering effect and commercial cuvettes containing 200 μ l of liquid, and having a total thickness crossed by the light of 5 mm were used.
15 By adding a concentration of bBSA up to few nM shows that most of the beads form clusters in larger agglomerates, thus dramatically reducing the signal amplitude, and lowering the frequency peak at few Hz. Large agglomerates are able to follow the external field variation only at low frequencies and, when magnetically aligned they scatter less than single particles and this cause the strong reduction of the signal. At
20 low concentration, only small agglomerates of particles are likely to be formed, and this is indicated by the lower frequency peak of the particle suspension. For this experiment, a consistent change in the signal can be observed down to bBSA concentration down to 100 pM.

25 Figure 10a illustrates a modified setup of a biosensor 1000 where figure 10b is a close-up view of the light-paths through the optical reservoir. In the modified setup 1000, a reflecting object 124, such as e.g. a mirror, is positioned such that the light transmitted through the solution of magnetic particles 102 in the optical reservoir 104 is reflected back (marked as item 132) through the optical reservoir 104 again
30 by the reflecting object 124. The light 133 having passed the optical reservoir 104 at least twice is afterwards detected by the detection unit 114.

By having light, which passes the particles suspension 102 twice, the light scattered by the formation and disruption of magnetic particle chains driven by the external magnetic field is increased.

5 In figures 10a-b, the detection unit 114 is shown as being integrated into the light source unit 110. This is however not a requirement and the two units could also be separated units. If the latter is the case, the transmitted light 133 having passed the optical reservoir 104 at least twice will have to be separated from the incoming light 112. This can be done in many different ways, by e.g. tilting the reflecting object 124
10 such that the light beams do not overlap spatially, or by inserting one or more objects, which direct the transmitted light 133 towards a separate detection unit 114.

In figures 10a-b, the oscillating magnetic field 108 is generated by a magnetic field generation unit 106 consisting of two electromagnets positioned in a $\mathbf{B} \perp \mathbf{k}$
15 configuration compared to the light 112 from the light source 110. The parallel configuration could however equally well have been used.

Like in the setup shown and described in figures 1-2, the magnetic particles suitable for use in the setup in figures 10a-b can be functionalized with a bioactive ligand,
20 such as e.g. antibodies, DNA, RNA, peptides, proteins, or protein complexes.

The magnetic particles will normally have a non-zero remnant magnetic moment and further be present in a suspension concentration in the range of 1 $\mu\text{g/mL}$ to 50 $\mu\text{g/mL}$.
25

The magnetic particles can also be substantially spherical or have a more irregular shape. The substantially spherical magnetic particles may have a diameter between 10 and 3000nm.

30 When using a biosensor as shown in figure 10a-b, the setup 1000 can be implemented in a DVD-type setup as shown and further explained in the following figures. The light source 110 in this kind of setup would then be a laser implemented in an optical pickup head, e.g. a CD, a DVD-ROM or a BLU-RAY optical pickup head. The laser light 112 would then be passed through a magnetic particle

suspension inserted in between two electromagnets and then be reflected back to the pickup head photodetector by a mirror 124. In this way there is no need for any additional lens or photodetector to measure the transmitted light, since the optical drive can also be used as the detection unit.

5

When using the DVD-type setup, the light emitted by the pickup head is already polarized, thus simply enhancing the scattering effects from the magnetic fluid. Also, the pickup head already contains magnetic elements and coils and the photodetector is therefore already screened from the effects of magnetic fields.

10

Further, by removing the lenses already present in the DVD pickup head, a larger beam size (few mm in diameter) capable of interacting with a large quantity of particles is obtainable.

15

In figure 11 is shown a disc 1002 with optical reservoirs implemented on it. The disc 1002 comprises at least one optical reservoir 1004, and at least one sample injection system for e.g. injection, dilution and mixing of the suspension of magnetic particles and the sample to be analyzed. The sample injection system may comprise at least one micro-needle 1006. The micro-needle 1006 is adapted for injection, dilution and mixing of the suspension of magnetic particles and the sample to be analyzed in at least one micro-channel 1004.

20

25

The biosensor described above can for all embodiments be used for diagnostic purposes. The biosensor could e.g. be used for analyzing blood, saliva, urine, water, plasma, or serum.

30

An injection point can be composed by at least one of the micro-needles 1006 which is used for collecting e.g. a blood sample from the user. The sample is centrifuged, diluted and mixed with a magnetic beads suspension through the dedicated centrifugal micro-channel system 1004.

The disc 1002 may comprise a plurality of microfluidic systems. The functionalized magnetic particles 102 in each of the plurality of optical reservoirs 104 can be

different from the functionalized magnetic particles in the other optical reservoirs or be similar. This allows for simultaneous detection of multiple samples.

- The measurement detecting magnetic particle dynamics by light transmission using a biosensor according to the above typically comprises the steps of:
- 5 - mixing a sample fluid to be analyzed with a suspension of magnetic particles in an optical reservoir;
 - directing a light source emitting light at a wavelength λ with an intensity I through the optical reservoir;
 - 10 - providing an uniaxial magnetic field oscillating at a frequency f_x ;
 - applying the uniaxial magnetic field to the optical reservoir whereby the suspension of magnetic particles is modulated such that the intensity I_{trans} of light transmitted through the suspension of magnetic particles is modulated compared to the intensity I_{in} of the light entering the optical reservoir;
 - 15 - sweeping the uniaxial magnetic field from a starting frequency $f_{x, start}$ to an end frequency $f_{x, end}$; and
 - measuring the intensity I_{trans} of the light transmitted through the suspension of magnetic particles in the optical reservoir at a frequency f_y varying between a start frequency $f_{y, start}$ and an end frequency $f_{y, end}$ as the uniaxial magnetic field is swept from the start frequency $f_{x, start}$ to the end frequency $f_{x, end}$, the frequency f_y being different from the first harmonic component f_x
 - 20

In the measurements, the setup of figure 1 or figure 10a can be used.

- 25 A detection scheme can be implemented for all measurement setups, where both the frequency of the light from the light source modulated e.g. by switching the light on/off and the frequency of the magnetic field are modulated each at two (or more) frequencies. The signal is in this situation detected as an integer combination of these two (or more) frequencies.

- 30 The biosensor is primarily for measuring dynamic behaviours of magnetic particles driven by the oscillating uniaxial magnetic field. Alternatively, the biosensor can also be used for time-resolved measurements of the particles relaxation after the application of an external magnetic field.

Detection of the target molecule/cell/bacteria can be achieved by measuring the increase of the hydrodynamic diameter of the particles when the target molecules bind to the specifically functionalized particle surface.

5

Detection of the target molecule/cell/bacteria can also be achieved by target molecule induced aggregate formation of specifically functionalized magnetic particles of the same type (i.e. agglutination assay).

- 10 Further, detection of the target molecule/cell/bacteria may be achieved by target molecule induced aggregate formation of specifically functionalized particles of different types such as magnetic/nonmagnetic, particles of different sizes or by having fluorescent dyes on the surface. Microfluidic operations, as, for example centrifugation, size separation via electrical or magnetic field gradient, can be used
- 15 to further separate different populations of particles or clustered particles from non-clustered ones, enabling the implementation of different types or readout schemes.

These are three of the most general way one can use this system as a biosensor.

References

- 100 biosensor
- 102 solution of magnetic particles
- 104 optical reservoir
- 5 106 magnetic field generation unit
- 108 oscillating uniaxial magnetic field
- 110 light source
- 112 light from the light source
- 113 transmitted light
- 10 114 detection unit
- 116 photodiode
- 118 lock-in amplifier
- 120 gauss meter
- 122 polarizer
- 15 124 reflecting object, e.g. a mirror
- 132 reflected transmitted light
- 133 transmitted light having passed the optical reservoir at least twice
- 200 temporal variation of the transmitted light
- 202 oscillating external magnetic field waveform
- 20 204 measured AC component of the photodetector signal under the oscillating magnetic field
- 206 measured AC component of the photodetector signal in absence of the oscillating magnetic field
- 300 Fast Fourier Transform (FFT) signal
- 25 400 2nd harmonic signal
- 402 in-phase component of the 2nd harmonic signal
- 404 out-of-phase component of the 2nd harmonic signal
- 412 fit of curve 402
- 414 fit of curve 404
- 30 500 in-phase component of the 2nd harmonic signal
- 502 $\mathbf{B} \parallel \mathbf{k}$
- 504 $\mathbf{B} \perp \mathbf{k}$ and $\theta = 0^\circ$
- 506 $\mathbf{B} \perp \mathbf{k}$ and $\theta = 90^\circ$
- 508 $\mathbf{B} \perp \mathbf{k}$ and circular polarization

- 510 out-of-phase component of the 2nd harmonic signal
512 $\mathbf{B} \parallel \mathbf{k}$
514 $\mathbf{B} \perp \mathbf{k}$ and $\theta = 0^\circ$
516 $\mathbf{B} \perp \mathbf{k}$ and $\theta = 90^\circ$
5 518 $\mathbf{B} \perp \mathbf{k}$ and circular polarization
520 $\mathbf{B} \parallel \mathbf{k}$ and $\theta = 90^\circ$
522 $\mathbf{B} \parallel \mathbf{k}$ and circular polarization
600 in-phase component of the 2nd harmonic signal
602 concentration of 1 $\mu\text{g/mL}$
10 604 concentration of 2 $\mu\text{g/mL}$
606 concentration of 5 $\mu\text{g/mL}$
608 concentration of 10 $\mu\text{g/mL}$
700 in-phase component of the 2nd harmonic signal
702 applied field amplitude of 1 mT
15 704 applied field amplitude of 1.5 mT
706 applied field amplitude of 2 mT
708 applied field amplitude of 2.5 mT
710 applied field amplitude of 3 mT
800 in-phase component of the 2nd harmonic signal
20 802 particles having a size of 50 nm
804 particles having a size of 130 nm
806 particles having a size of 250 nm
900 in-phase component of the 2nd harmonic signal
902 biotinylated BSA concentration of 0 pM
25 904 biotinylated BSA concentration of 100 pM
906 biotinylated BSA concentration of 250 pM
908 biotinylated BSA concentration of 500 pM
910 biotinylated BSA concentration of 900 pM
912 biotinylated BSA concentration of 2000 pM
30 1000 modified biosensor
1002 disc
1004 micro-channel
1006 micro-needle

1008 digital track area

1010 optical drive

Claims

1. A biosensor comprising:
 - a suspension of magnetic particles;
 - an optical reservoir containing the suspension of magnetic particles;
 - 5 - a light source emitting light at a wavelength λ with an intensity I , the light source being directed at the optical reservoir and being adapted for interacting with the suspension of magnetic particles, where the light entering the optical reservoir has an intensity I_{in} and light transmitted through the optical reservoir has an intensity I_{trans} ;
 - 10 - a magnetic field generation unit generating an oscillating uniaxial magnetic field oscillating at a frequency f_x being variable between a start frequency $f_{x, start}$ and an end frequency $f_{x, end}$, the oscillating uniaxial magnetic field being applied to the optical reservoir containing the suspension of magnetic particles whereby the suspension of magnetic particles is modulated such that the intensity I_{trans} of light transmitted through the suspension of magnetic particles is modulated compared to the intensity I_{in} of the light entering the optical reservoir; and
 - 15 - a detection unit measuring the intensity I_{trans} of the light transmitted through the suspension of magnetic particles in the optical reservoir wherein the modulation of the intensity I_{trans} of the transmitted light is detected at a frequency f_y varying between a start frequency $f_{y, start}$ and an end frequency $f_{y, end}$ as the oscillating uniaxial magnetic field is swept from the start frequency $f_{x, start}$ to the end frequency $f_{x, end}$, wherein the detected frequency f_y is different from the first harmonic component f_x .
 - 20
 - 25
2. A biosensor according to claim 1 wherein second harmonic ($f_y = 2f_x$) or higher harmonic components of the intensity I_{trans} of the transmitted light is detected by the detection unit.
- 30 3. A biosensor according to claim 1 or 2 wherein the magnetic particles are functionalized with a bioactive ligand, such as e.g. antibodies, DNA, RNA, peptides, proteins, or protein complexes.

4. A biosensor according to any preceding claim wherein the magnetic particles have a non-zero remnant magnetic moment.
- 5 5. A biosensor according to any preceding claim wherein the magnetic particles is present in a suspension concentration in the range of 0.1 $\mu\text{g/mL}$ to 2000 $\mu\text{g/mL}$.
6. A biosensor according to any preceding claim wherein the magnetic particles are magnetic beads, such as e.g. magnetic polymeric beads.
- 10 7. A biosensor according to any preceding claim wherein the magnetic particles are substantially spherical, in the sense that individual particles have negligible optical anisotropy along the applied oscillating uniaxial magnetic field.
- 15 8. A biosensor according to claim 7 wherein the substantially spherical magnetic particles have a diameter between 10 and 3000 nm.
- 20 9. A biosensor according to any preceding claim wherein the magnetic field generation unit is an electromagnet generating a time varying magnetic field between $f_{x, \text{start}} = 0.1 \text{ Hz}$ and $f_{x, \text{end}} = 10 \text{ kHz}$, the magnetic field having a magnetic field intensity between 0.1 mT and 5 mT.
- 25 10. A biosensor according to any preceding claim wherein the light source is a UV lamp, a light emitting diode (LED), a laser emitting light in e.g. the ultra violet (UV) or visible or infrared (IR) spectral range.
- 30 11. A biosensor according to any preceding claim wherein the light emitted from the light source is linearly polarized.
12. A biosensor according to any preceding claim further comprising a polarizer positioned between the light source and the optical reservoir.
13. A biosensor according to any preceding claims further comprising at least one reflecting object positioned such that:

- the light being transmitted through and being modulated by the suspension of magnetic particles in the optical reservoir, and/or
 - the light transmitted through the optical reservoir not being modulated by the suspension of magnetic particles,
- 5 is reflected back through the optical reservoir by the reflecting object.
14. A biosensor according to any preceding claims wherein the light source and the detection unit are integrated into an optical pickup head, e.g. from or in a CD player/recorder, a DVD player/recorder or a Blu-ray player/recorder.
- 10
15. Use of a biosensor according to any of claims 1-14 for diagnostic purposes.
16. A method for detecting magnetic particle dynamics by light transmission using a biosensor according to any of claim 1-14, the method comprising the steps of:
- 15
- mixing a sample fluid to be analyzed with a suspension of magnetic particles in an optical reservoir;
 - directing a light source emitting light at a wavelength λ with an intensity I through the optical reservoir;
 - providing an uniaxial magnetic field oscillating at a frequency f_x ;
- 20
- applying the uniaxial magnetic field to the optical reservoir whereby the suspension of magnetic particles is modulated such that the intensity I_{trans} of light transmitted through the suspension of magnetic particles is modulated compared to the intensity I_{in} of the light entering the optical reservoir;
 - sweeping the uniaxial magnetic field from a starting frequency $f_{x, start}$ to an
- 25
- end frequency $f_{x, end}$; and
 - measuring the intensity I_{trans} of the light transmitted through the suspension of magnetic particles in the optical reservoir at a frequency f_y varying between a start frequency $f_{y, start}$ and an end frequency $f_{y, end}$ as the uniaxial magnetic field is swept from the start frequency $f_{x, start}$ to the end frequency
- 30
- $f_{x, end}$, the frequency f_y being different from the first harmonic component f_x .
17. A method according to claim 17 wherein second harmonic ($f_y = 2f_x$) or higher harmonic components of the intensity I_{trans} of the transmitted light is measured.

18. A method according to claim 17 or 18 wherein the uniaxial magnetic field is swept from a start frequency of $f_{x, \text{start}} = 0.1$ Hz to an end frequency of $f_{x, \text{end}} = 10$ kHz.

1/10

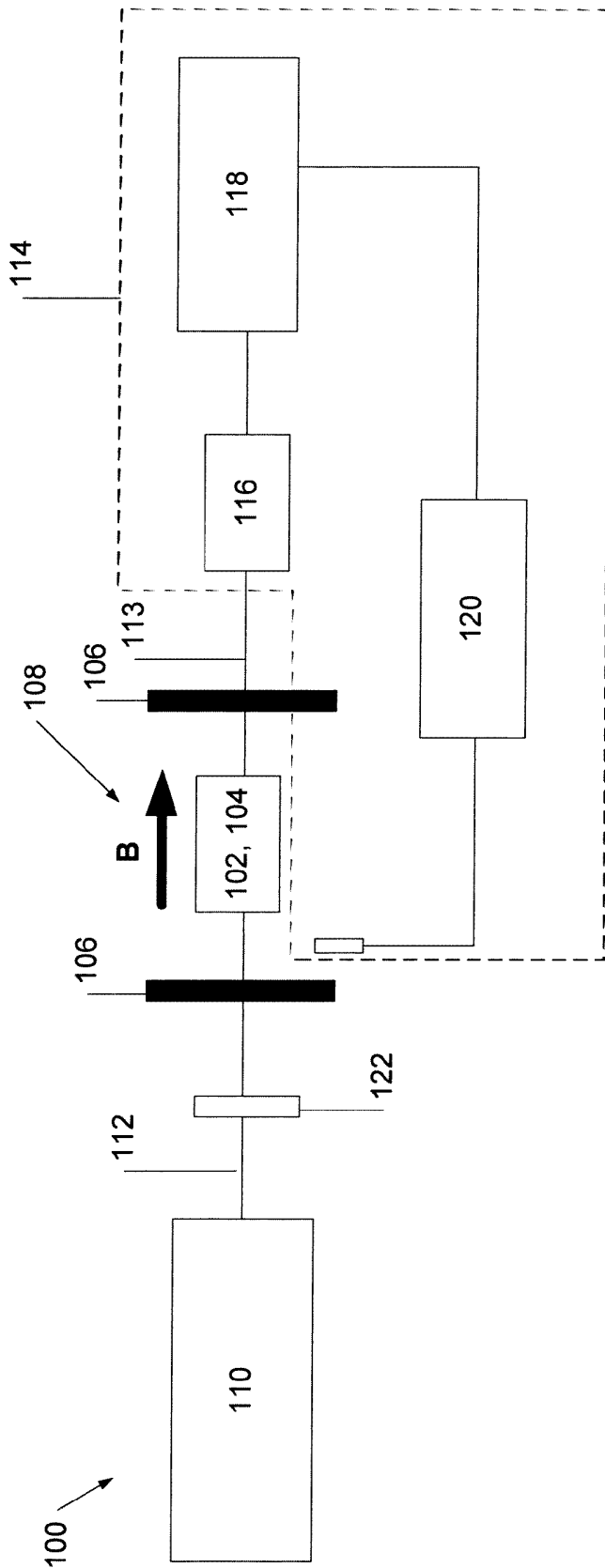

Fig. 1

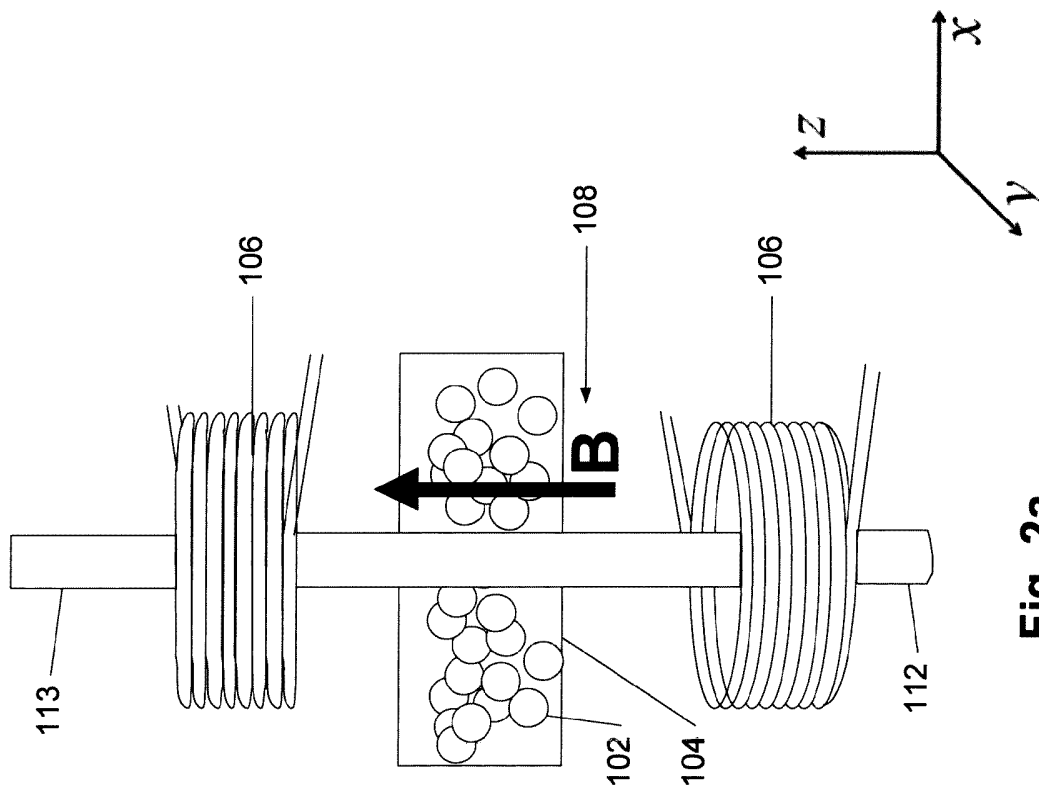

Fig. 2a

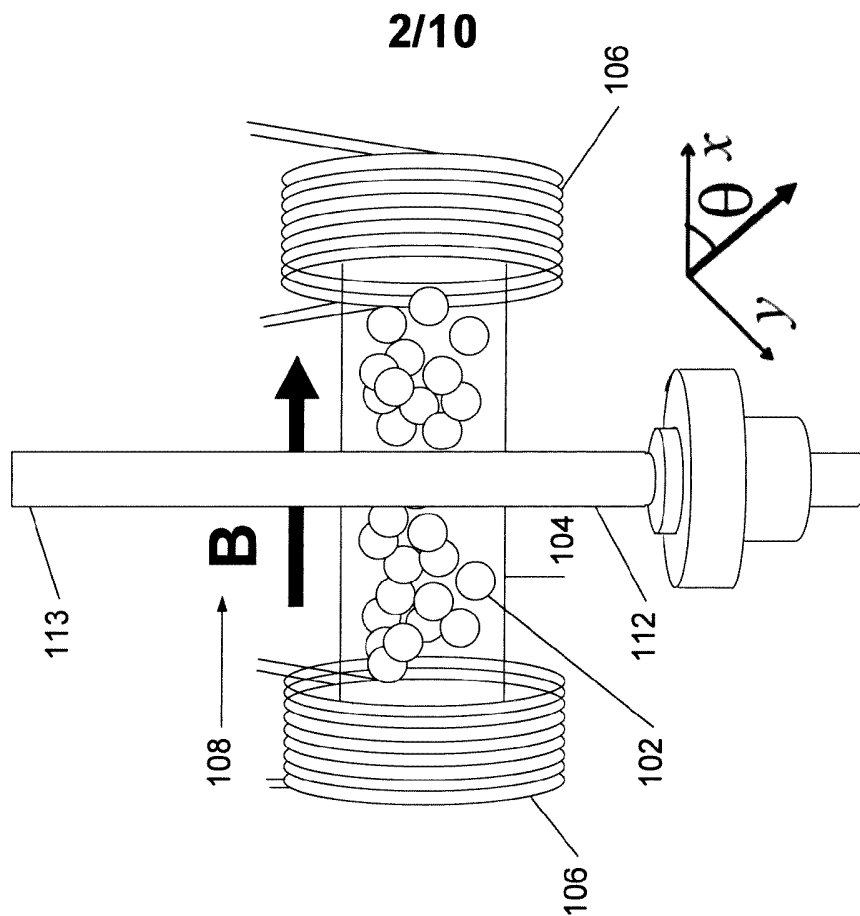

Fig. 2b

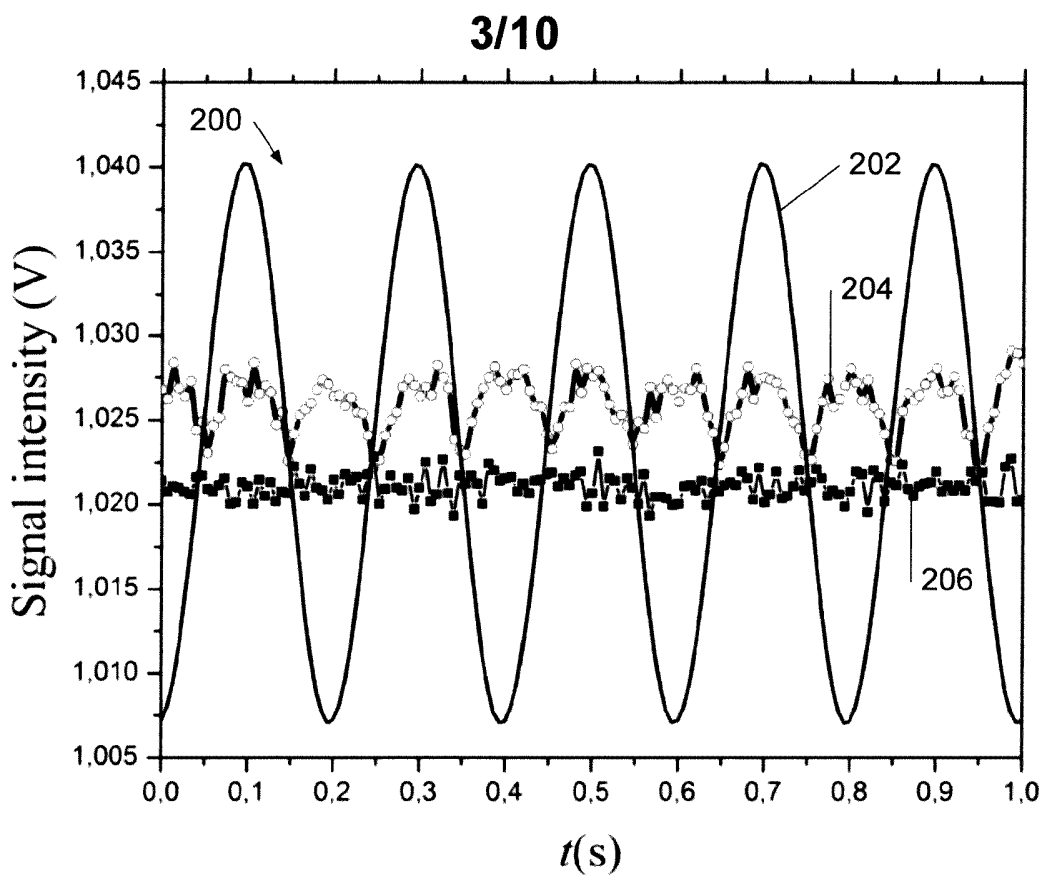

Fig. 3a

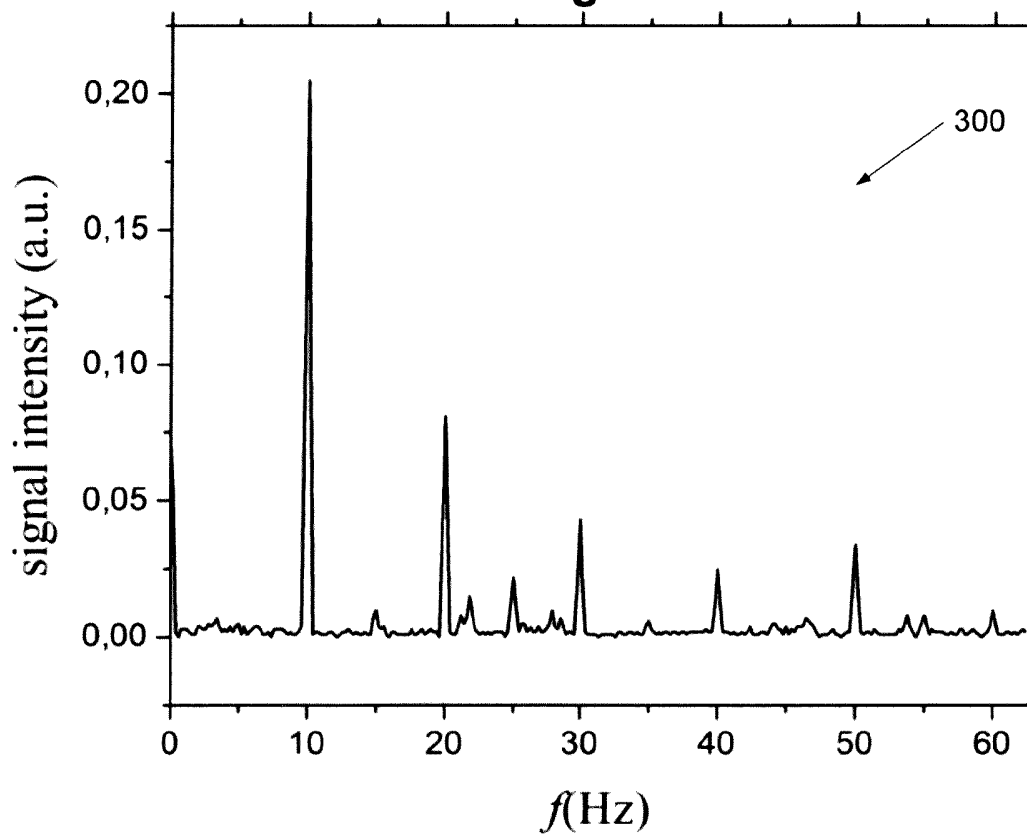
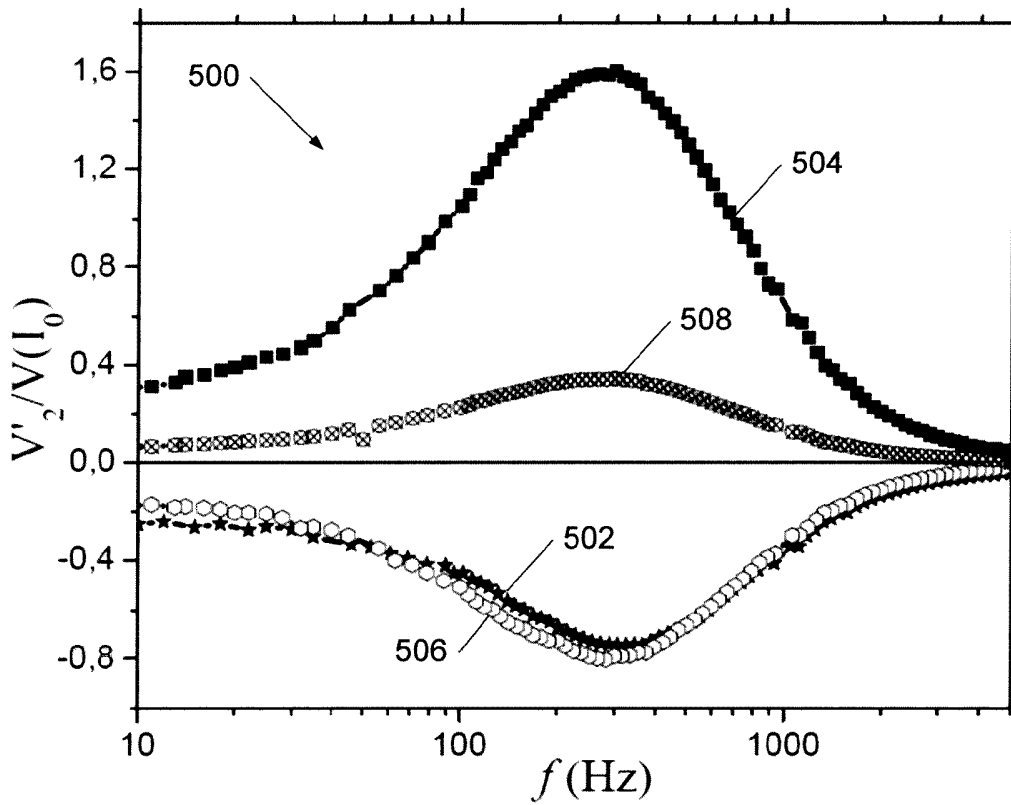
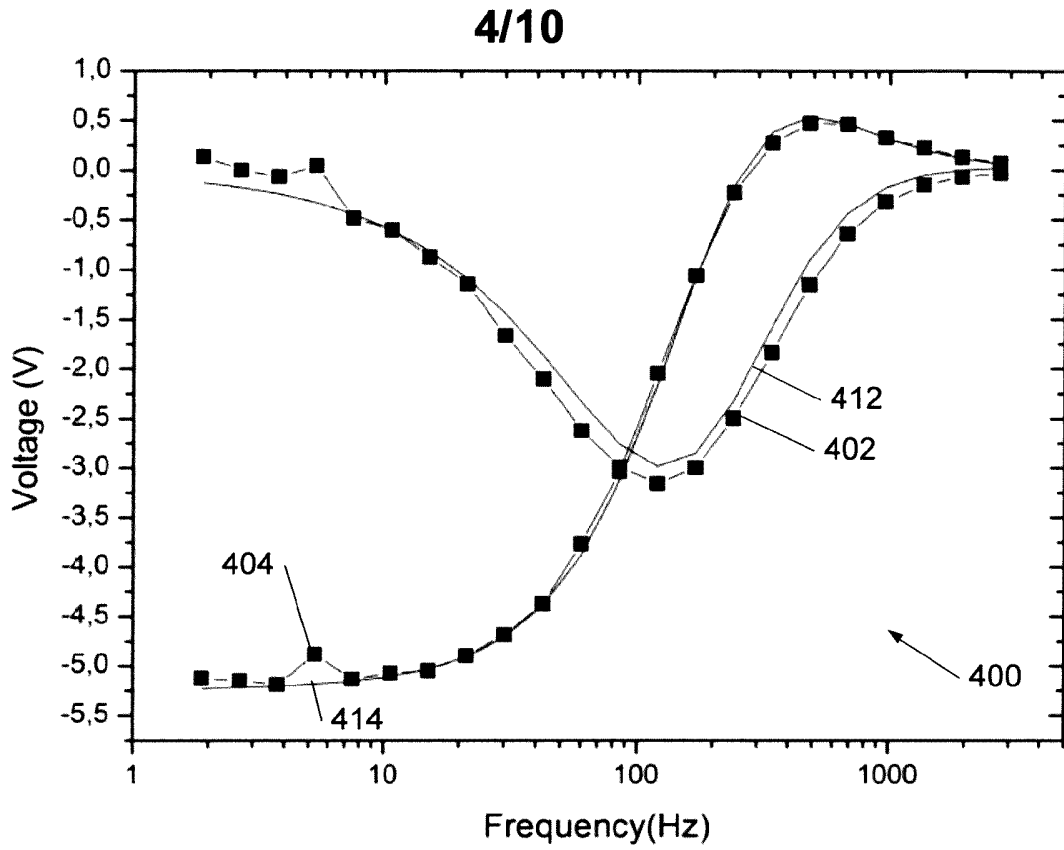

Fig. 3b



5/10

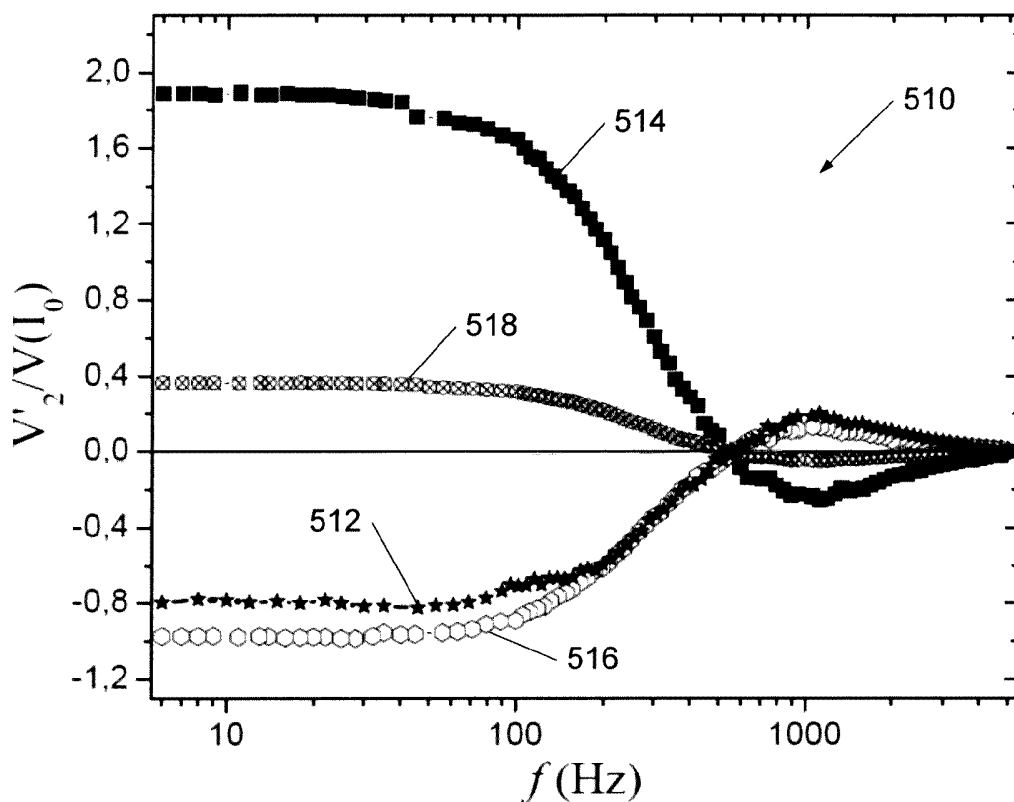

Fig. 5b

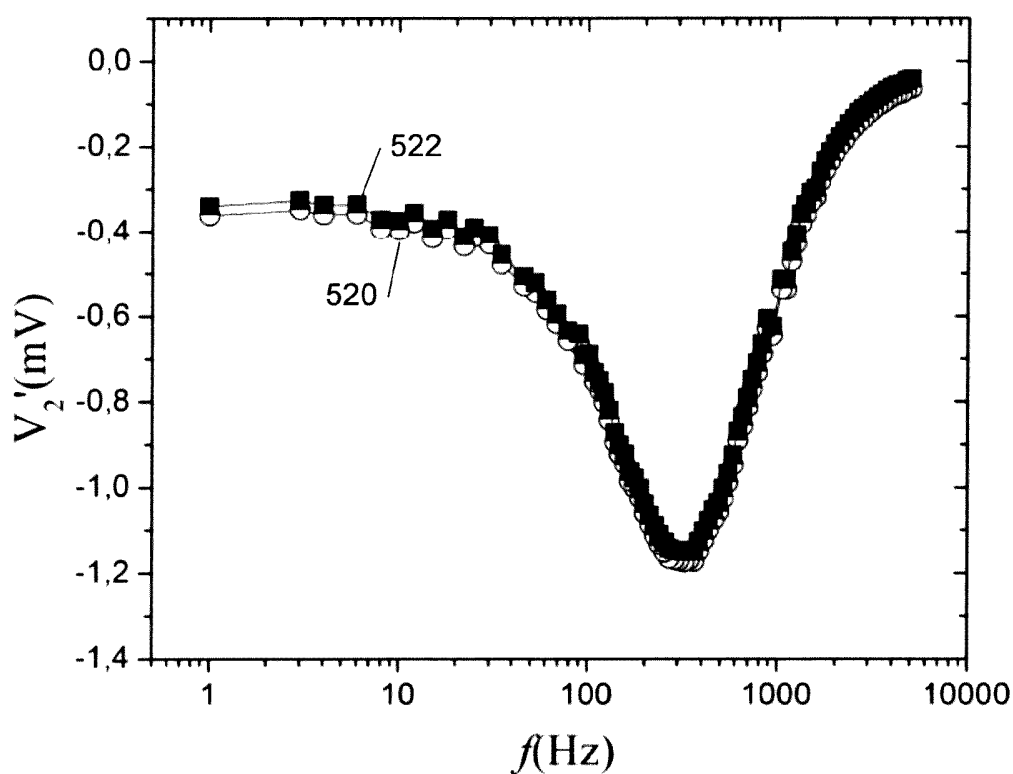

Fig. 5c

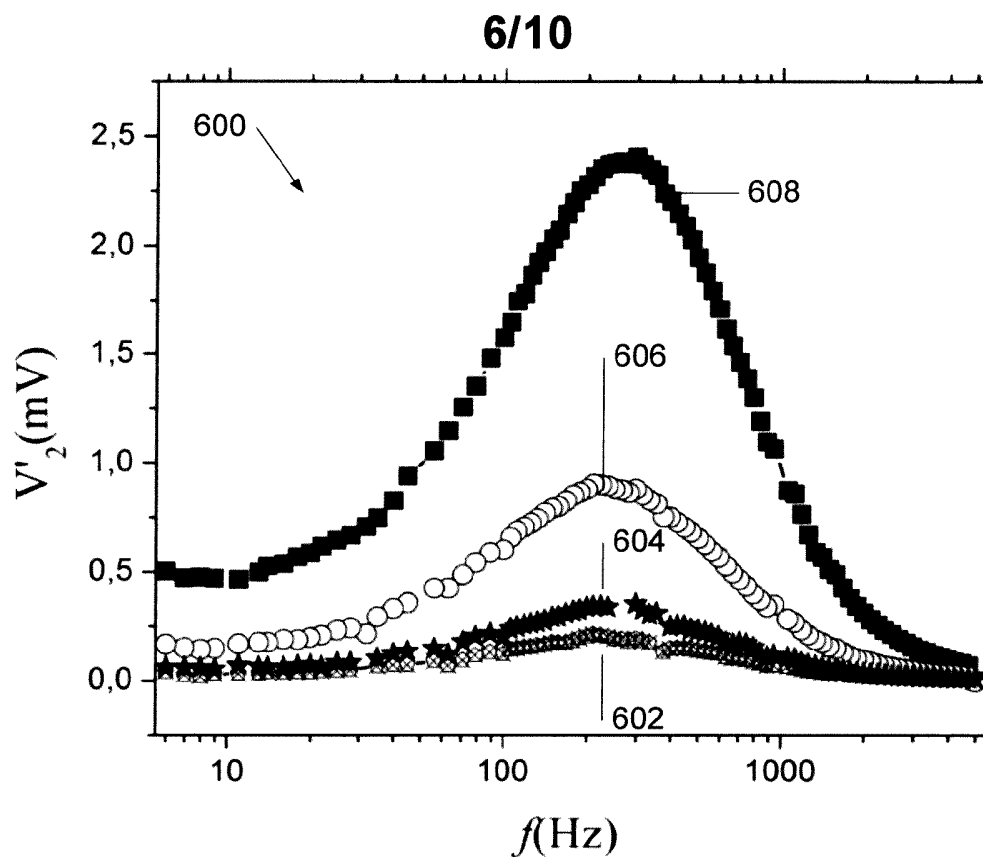

Fig. 6

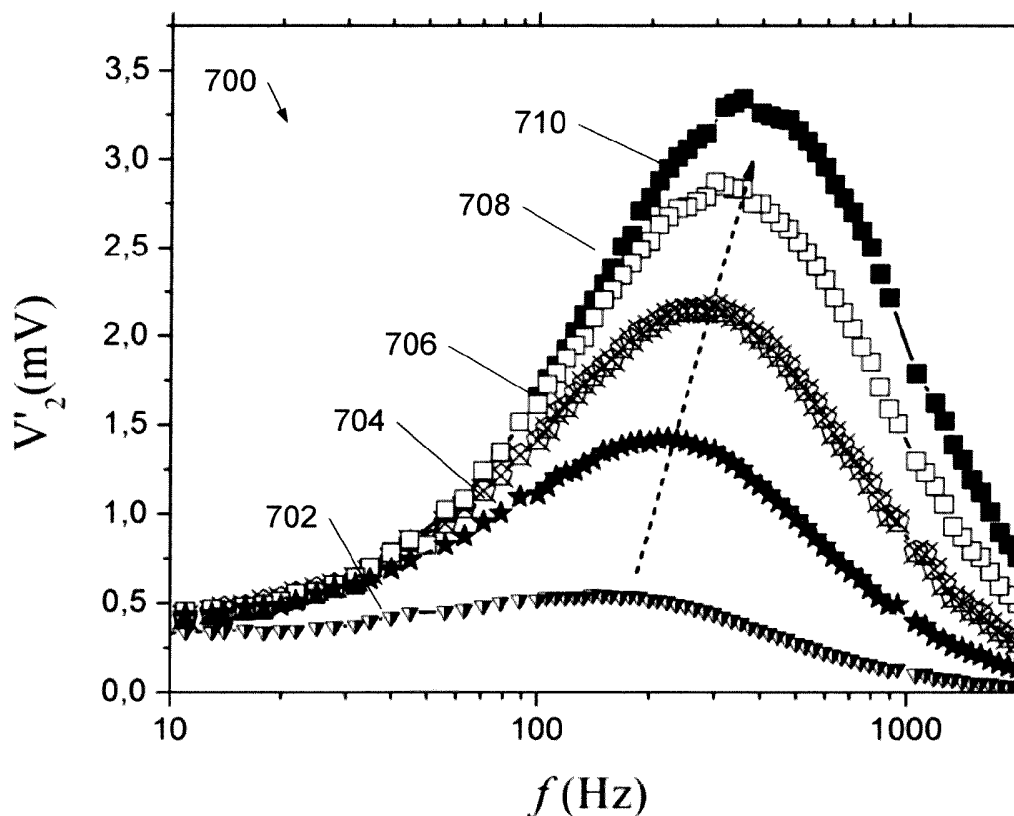

Fig. 7

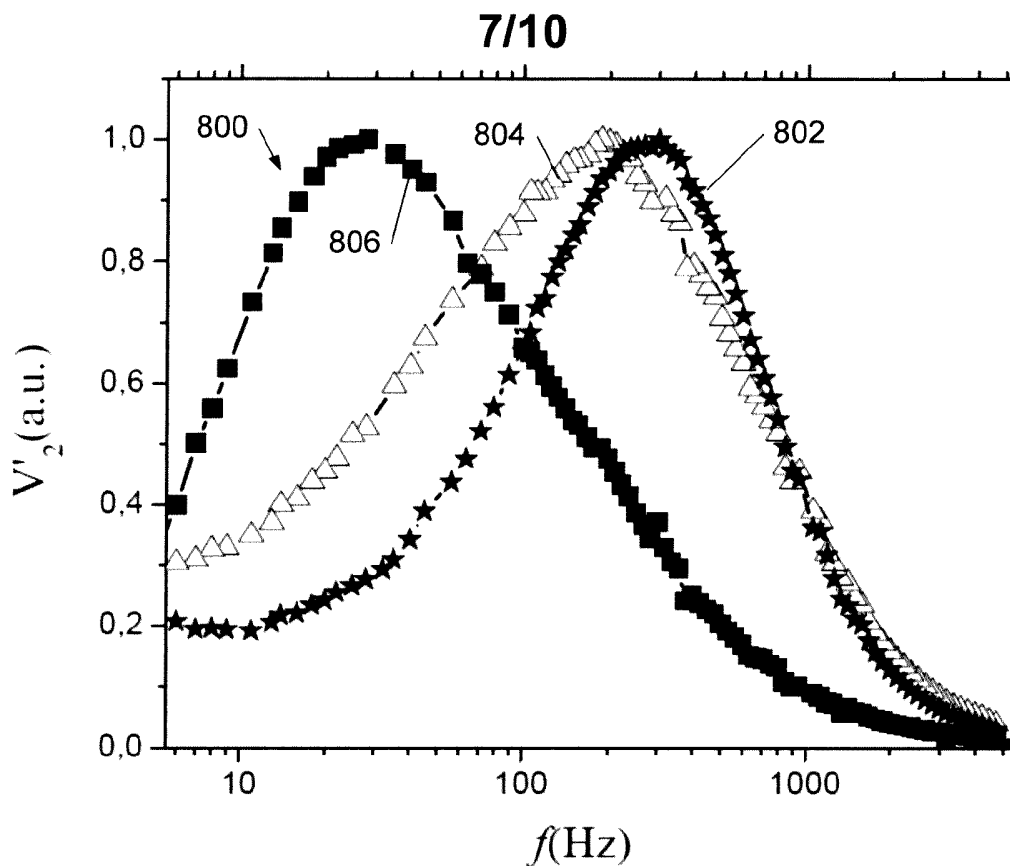

Fig. 8

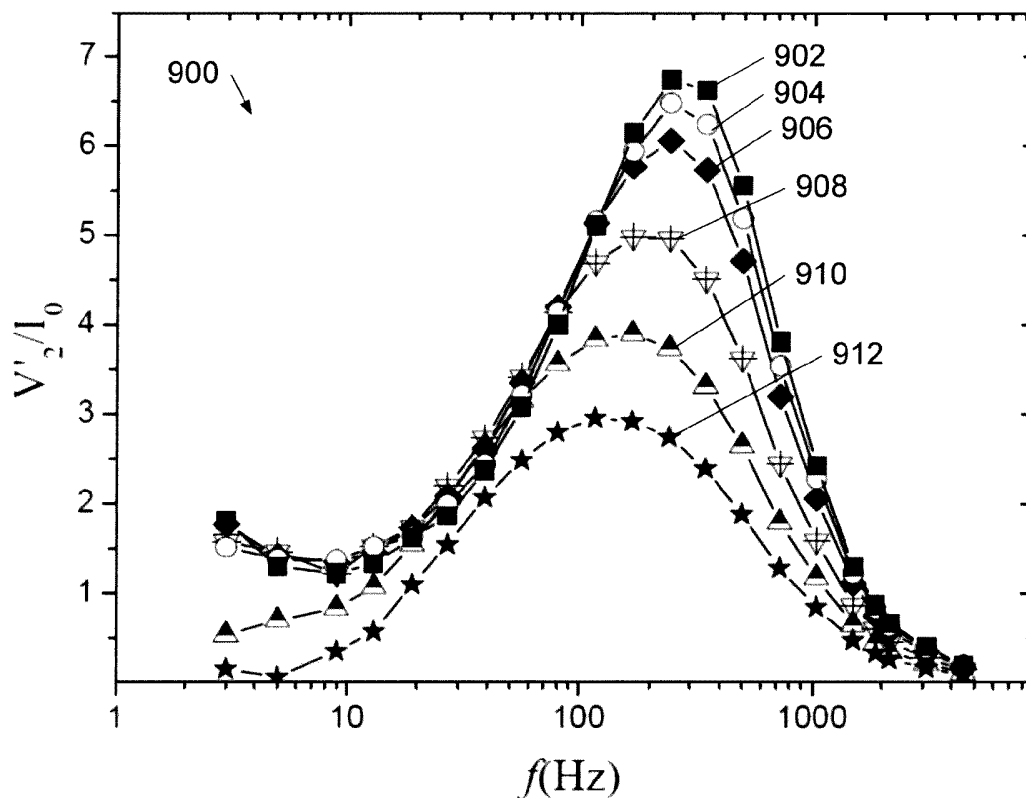

Fig. 9a

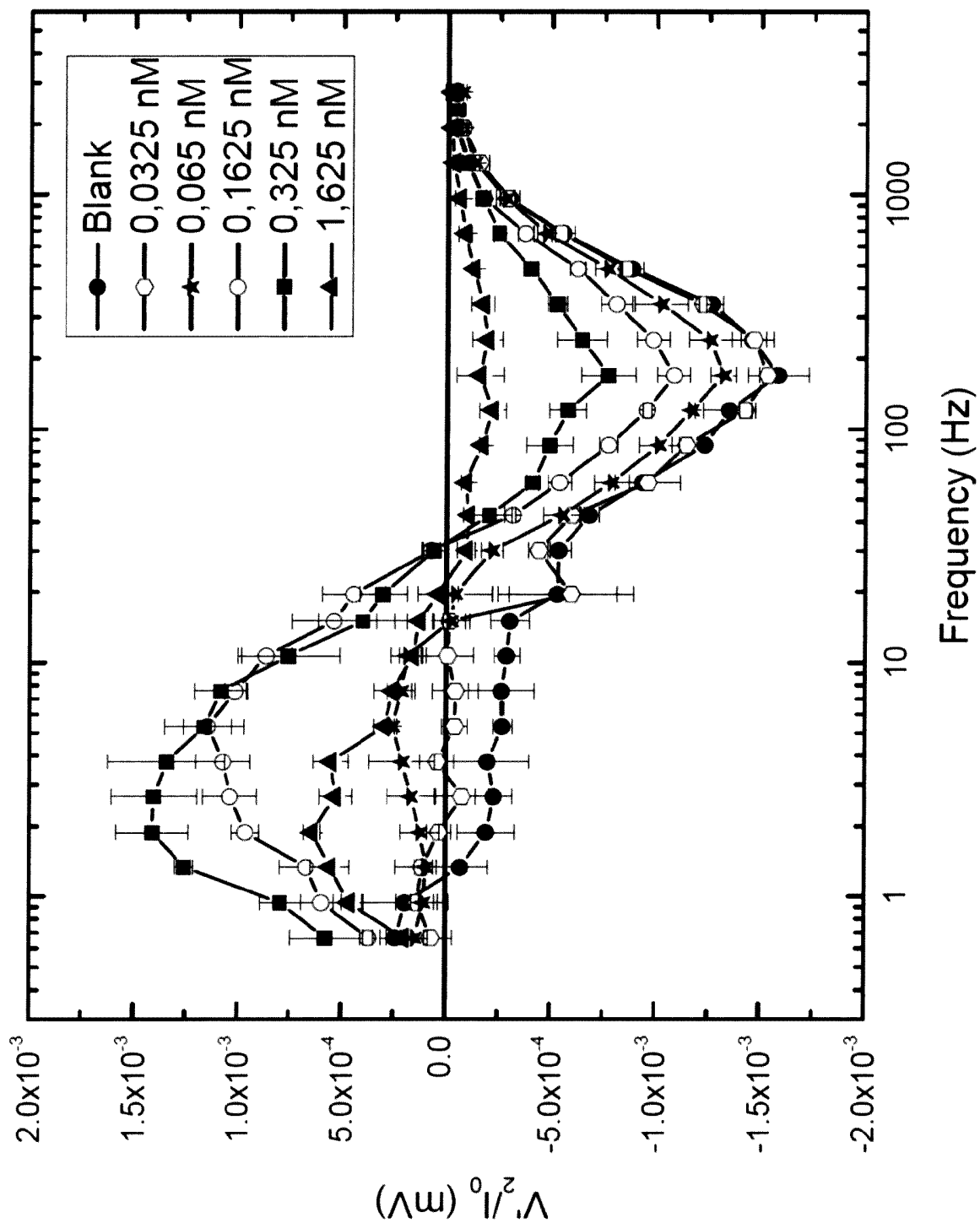

Fig. 9b

9/10

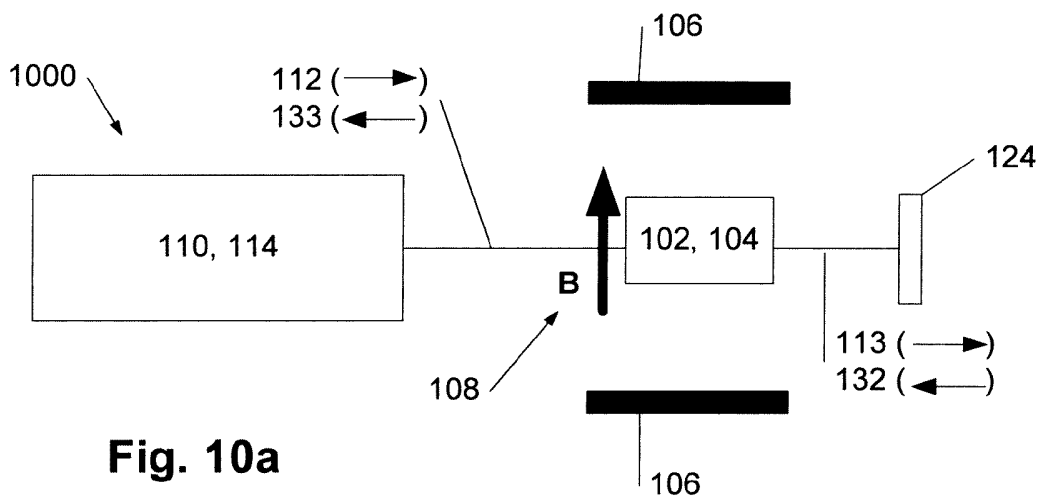

Fig. 10a

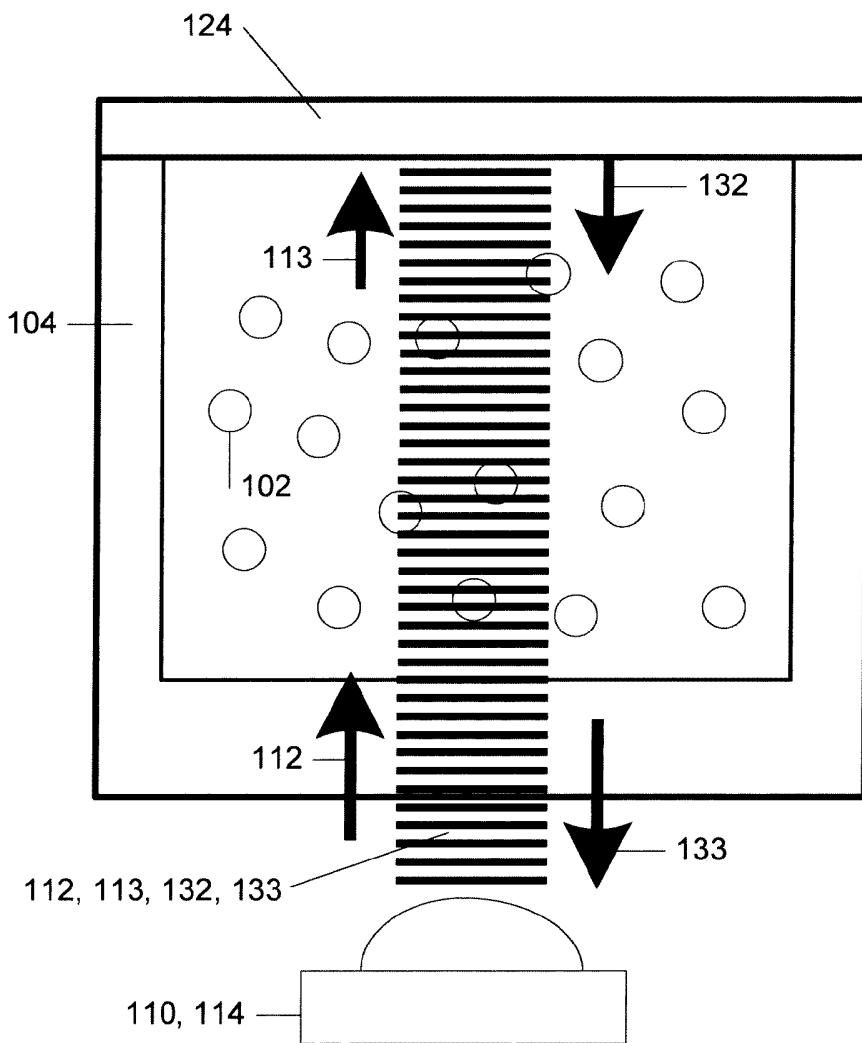

Fig. 10b

10/10

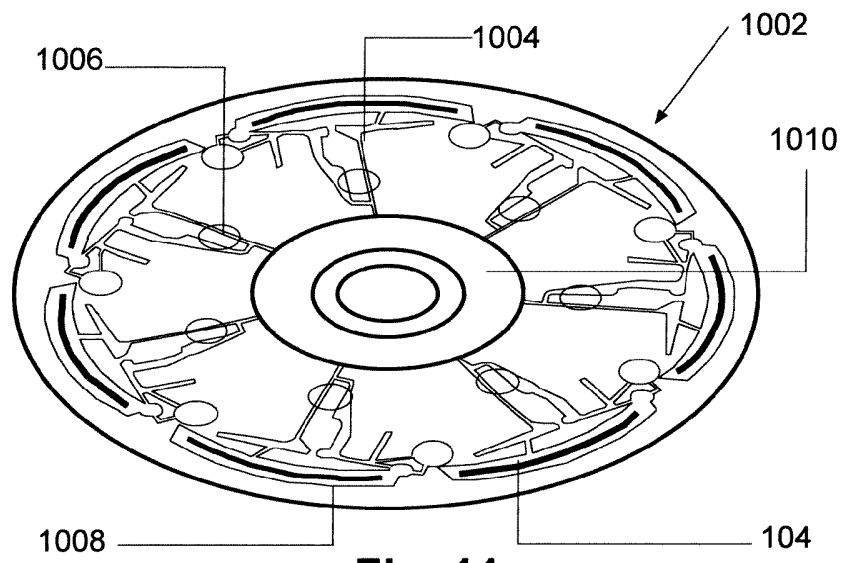

Fig. 11

INTERNATIONAL SEARCH REPORT

International application No PCT/EP2014/055883

A. CLASSIFICATION OF SUBJECT MATTER INV. G01N21/17 G01N33/543 ADD.		
According to International Patent Classification (IPC) or to both national classification and IPC		
B. FIELDS SEARCHED		
Minimum documentation searched (classification system followed by classification symbols) G01N		
Documentation searched other than minimum documentation to the extent that such documents are included in the fields searched		
Electronic data base consulted during the international search (name of data base and, where practicable, search terms used) EPO-Internal		
C. DOCUMENTS CONSIDERED TO BE RELEVANT		
Category*	Citation of document, with indication, where appropriate, of the relevant passages	Relevant to claim No.
Y	US 7 639 359 B2 (CHUNG SEOK-HWAN [US] ET AL) 29 December 2009 (2009-12-29) cited in the application column 3, line 27 - column 5, line 42 figure 2	1-18
Y	----- US 4 725 140 A (MUSHA TOSHIMITSU [JP]) 16 February 1988 (1988-02-16) column 3, lines 4-68 column 8, lines 2-11 figures 1, 6B	1-18
Y	----- US 2003/003464 A1 (PHAN BRIGITTE C [US] ET AL) 2 January 2003 (2003-01-02) paragraphs [0060] - [0062]; figure 4 -----	13,14
<input type="checkbox"/> Further documents are listed in the continuation of Box C.		
<input checked="" type="checkbox"/> See patent family annex.		
* Special categories of cited documents :		
"A" document defining the general state of the art which is not considered to be of particular relevance "E" earlier application or patent but published on or after the international filing date "L" document which may throw doubts on priority claim(s) or which is cited to establish the publication date of another citation or other special reason (as specified) "O" document referring to an oral disclosure, use, exhibition or other means "P" document published prior to the international filing date but later than the priority date claimed	"T" later document published after the international filing date or priority date and not in conflict with the application but cited to understand the principle or theory underlying the invention "X" document of particular relevance; the claimed invention cannot be considered novel or cannot be considered to involve an inventive step when the document is taken alone "Y" document of particular relevance; the claimed invention cannot be considered to involve an inventive step when the document is combined with one or more other such documents, such combination being obvious to a person skilled in the art "&" document member of the same patent family	
Date of the actual completion of the international search	Date of mailing of the international search report	
6 June 2014	16/06/2014	
Name and mailing address of the ISA/ European Patent Office, P.B. 5818 Patentlaan 2 NL - 2280 HV Rijswijk Tel. (+31-70) 340-2040, Fax: (+31-70) 340-3016	Authorized officer Hoogen, Ricarda	

INTERNATIONAL SEARCH REPORT

Information on patent family members

International application No

PCT/EP2014/055883

Patent document cited in search report	Publication date	Patent family member(s)	Publication date
US 7639359	B2	29-12-2009	NONE
US 4725140	A	16-02-1988	DE 3639352 A1 25-06-1987
			JP H054021 B2 19-01-1993
			JP S62118255 A 29-05-1987
			US 4725140 A 16-02-1988
US 2003003464	A1	02-01-2003	NONE