



Determining the Velocity Fine Structure by a Laser Anemometer in VAD operation

Kristensen, Leif; Kirkegaard, Peter; Mikkelsen, Torben

Publication date:
2012

Document Version
Publisher's PDF, also known as Version of record

[Link back to DTU Orbit](#)

Citation (APA):
Kristensen, L., Kirkegaard, P., & Mikkelsen, T. (2012). *Determining the Velocity Fine Structure by a Laser Anemometer in VAD operation*. DTU Wind Energy. DTU Wind Energy E No. 0008

General rights

Copyright and moral rights for the publications made accessible in the public portal are retained by the authors and/or other copyright owners and it is a condition of accessing publications that users recognise and abide by the legal requirements associated with these rights.

- Users may download and print one copy of any publication from the public portal for the purpose of private study or research.
- You may not further distribute the material or use it for any profit-making activity or commercial gain
- You may freely distribute the URL identifying the publication in the public portal

If you believe that this document breaches copyright please contact us providing details, and we will remove access to the work immediately and investigate your claim.

Determining the Velocity Fine Structure by a Laser Anemometer in VAD operation

DTU Vindenergi
E Rapport 2012

Leif Kristensen, Peter Kirkegaard, and Torben Mikkelsen

DTU Wind Energy E-0008(EN)

August 2012

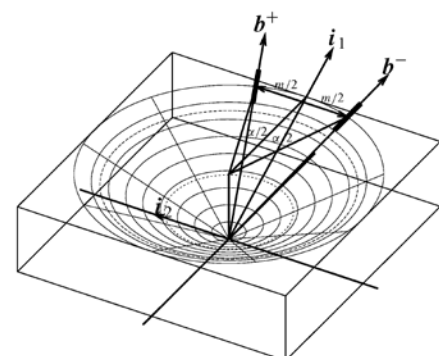
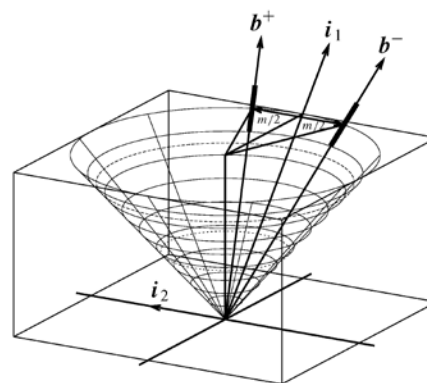

Forfatter(e): Leif Kristensen, Peter Kirkegaard, and Torben Mikkelsen
Titel: Determining the Velocity Fine Structure by a Laser Anemometer in VAD operation

Institut: Institut for Vindenergi

Resume:

The theoretical basis for determining the dissipation ϵ , by measuring the velocity structure function with a CW-laser anemometer has been derived in the case of calm wind conditions.

If there is a well defined mean wind speed the structure function can be obtained by having the laser beam pointing in one direction and measure a time series of the Doppler wind velocity component along the beam. Applying Taylor's hypothesis the structure function can be calculated. This technique was discussed by Kristensen et al. (2011).

Taylor's hypothesis cannot, however, be used if there is no mean wind. Then it is necessary to "create" a mean wind by turning the laser beam. Since the instrument is not moved the beam will describe a cone which could be a VAD-scanning.

In any case the measured velocity components will not be parallel and this implies that the measured structure function will contain a term which is proportional to the total variance.

The theoretical expression for the line-filtered structure function is derived in two equivalent ways, one in physical space and one in wave-number space, of which the last can be reliably evaluated by numerical integration.

Also a practical approximate equation, derived in the physical space, is presented.

August 31. 2012

Kontrakt nr.: FI Grant No. 2136-08-0022.

Projektnr.:
43065, x-1

Sponsorship: Danish Agency for Science-Technology and Innovation: Research Infrastructure 2009

Forside:

Sketch of a VAD lidars scanning geometry seen from two different points of view, cf. Figure 1 for details.

Sider: 40

Tabeller: 0

Referencer: 6

Danmarks Tekniske Universitet
DTU Vindenergi
Nils Koppels Allé
Bygning 403
2800 Kgs. Lyngby
Telefon (+45) 45 25 25 25
dtic@dtic.dtu.dk
www.vindenergi.dtu.dk

ISBN 978-87-92896-14-5

Forord

I denne rapport præsenteres en teori samt en praktisk metode til fjernmåling af turbulens i det atmosfæriske grænselag.

Metoden baserer sig på målinger med en jordbaseret vind lidar.

Vind lidaren er i dette tilfælde udstyret med et scannende prisme hvorved lidaren kan opereres i den såkaldte "Velocity Azimuth Display" (VAD) scanning mode, det vil sige, lidaren kan med sin laserstråle fokuseret på den ønskede målehøjde scanne vinden rundt på en cirkel over jorden. Samtidig registrerer vind lidaren den i målepunktet øjeblikkelige vindvektors projektion i den skannende laserstråles retning.

Med udgangspunkt i lidarens Doppler-skift bestemte radiale vindhastighedskomponenter udvikles en metode til bestemmelse af "Dissipation-rate" af turbulensen fra målehøjden.

Resultat har praktisk betydning for remote sensing baseret måling af atmosfærisk turbulens (dissipation rate), især for tilfælde hvor vindhastigheden i målehøjden er for lav til at "Taylors frozen turbulence hypothesis" kan bringes i anvendelse til omregning mellem tid og rum, eller frekvens og bølgetal.

DTU Risø Campus, August 2012

Torben Mikkelsen
Professor in Remote Sensing for Wind Energy

Summary

This report presents a theory and a practical method for remote measurement of turbulence in the atmospheric boundary layer.

The method is based on measurements from a single ground-based scanning wind lidar.

The wind lidar is equipped with a scanning prism device by which the lidar may be operated in the so-called "velocity azimuth display" (VAD) scan mode, that is, the lidar is able to move or scan its laser beam focused to the desired measuring height on a full circle or a part hereof above the ground. While scanning the wind lidar measures the projection of the instantaneous wind vector at the focus point along the scanning laser beams direction.

A theory including a practical approximation is derived that relates the lidars measured radial wind speed between two small-displaced arc-scans to the dissipation rate of the turbulence at the measurement height.

The findings have practical implications for remote sensing-based measurements of atmospheric turbulence (dissipation rate) for cases where the mean wind speed at the measurement height is too low to for Taylor's frozen turbulence hypothesis to apply for conversion between time and space, or frequency and wave number.

Determining the Velocity Fine Structure by a Laser Anemometer in VAD operation

Leif Kristensen, Peter Kirkegaard, and Torben Mikkelsen

**Technical University of Denmark,
Department of Wind Energy
Roskilde**

August 2012

Abstract The theoretical basis for determining the dissipation ε , by measuring the velocity structure function with a CW-laser anemometer has been derived in the case of calm wind conditions. If there is a well defined mean wind speed the structure function can be obtained by having the laser beam pointing in one direction and measure a time series of the Doppler wind velocity component along the beam. Applying Taylor's hypothesis the structure function can be calculated. This technique was discussed by Kristensen et al. (2011). Taylor's hypothesis cannot, however, be used if there is no mean wind. Then it is necessary to "create" a mean wind by turning the laser beam. Since the instrument is not moved the beam will describe a cone which could be a VAD-scanning. In any case the measured velocity components will not be parallel and this implies that the measured structure function will contain a term which is proportional to the total variance. The theoretical expression for the line-filtered structure function is derived in two equivalent ways, one in physical space and one in wave-number space, of which the last can be reliably evaluated by numerical integration. Also a practical approximate equation, derived in the physical space, is presented.

Contents

1	Introduction	<i>5</i>
2	VAD geometry	<i>5</i>
3	The Line Filtered Velocity Field	<i>7</i>
4	Physical Space	<i>9</i>
5	Wave-Number Space	<i>12</i>
6	Discussion	<i>18</i>
7	Results	<i>19</i>
8	Conclusion	<i>21</i>
A	Physical Space, Details	<i>23</i>
B	Wave-Number Formulation, Details	<i>34</i>
	Acknowledgements	<i>39</i>
	References	<i>40</i>

1 Introduction

In a previous study (Kristensen et al. 2011) we discussed the theory for determining the velocity structure function by means of a CW-laser anemometer with its beam pointing in one particular direction. This was a slight generalization of the work by Smalikho (1995). The basic idea is to determine a time series of the Doppler velocity component along the direction of the beam. Assuming Taylor’s hypothesis we may then obtain the structure function and, in turn, the rate of dissipation ε of specific kinetic energy. The condition for a successful application of Taylor’s hypothesis is that there is a mean-wind speed which is sufficiently large. Under calm or nearly calm conditions this hypothesis does not lead to satisfactory results. In this case the beam must move in order to “create” a mean wind. Here we discuss the VAD (Velocity Azimuth Display) technique for obtaining a constant velocity flow through the measuring volume. Figure 1 shows the setup. The laser beam forms the angle φ with the ground and moves to describe a cone with a vertical axis. A point on the beam at a fixed distance from the laser describes a circle. On the base of the cone is shown an isosceles triangle with the vertex α defined by the laser beams at two different times. On each beam the measuring volume is indicated. The distance from the laser to the center of this volume is R . In the following we may safely assume that the wind speed U is much smaller than $R\dot{\alpha} \cos \varphi$. The same basic approach was suggested by Banakh et al. (1999). Their theoretical derivation is outlined in much less detail than we will present in the following.

2 VAD geometry

Inspection of Fig. 1 shows that the distance between the measuring centers of the two beams is the chord

$$m = 2R \cos \varphi \sin(\alpha/2). \quad (1)$$

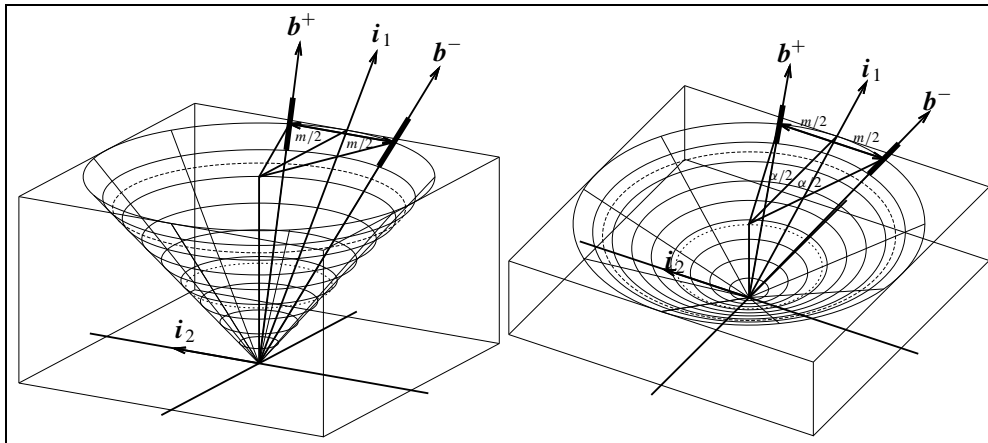

Figure 1. Sketch of the VAD geometry from two different points of view. The directions of the two beams are defined by the unit vectors \mathbf{b}^- and \mathbf{b}^+ . The chord m between the centers of the measuring volumes is shown. On the base of the cone is shown an isosceles triangle with the vertex α and the base with the length m . We use a Cartesian coordinate system defined by the orthogonal unit vectors (4)–(6). The two vectors \mathbf{i}_1 and \mathbf{i}_2 are shown.

We may simplify the derivation of the structure function for the VAD measurement by working in the plane, defined by two laser beams. Figure 2 is a plane figure defined by the two generators defined by \mathbf{b}^- and \mathbf{b}^+ .

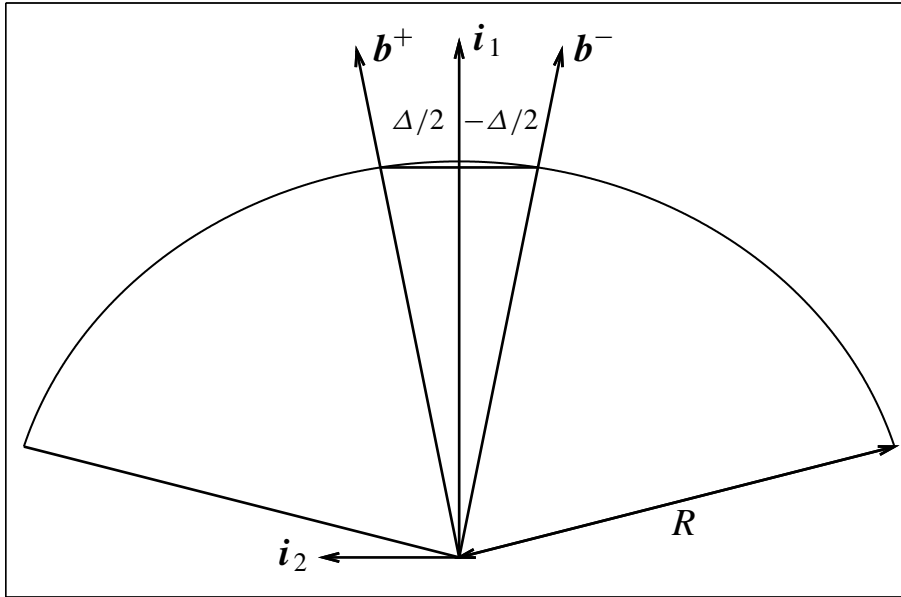

Figure 2. The geometry in the plane defined by \mathbf{b}^- and \mathbf{b}^+ . The chord m is shown.

The angle Δ between them is given by the equation

$$m = 2R \sin(\Delta/2). \quad (2)$$

so that

$$\Delta = 2 \arcsin(\cos \varphi \sin(\alpha/2)). \quad (3)$$

A Cartesian coordinate system is then defined by \mathbf{b}^- and \mathbf{b}^+ as follows

$$\mathbf{i}_1 = \frac{\mathbf{b}^- + \mathbf{b}^+}{|\mathbf{b}^- + \mathbf{b}^+|}, \quad (4)$$

$$\mathbf{i}_3 = \frac{\mathbf{b}^- \times \mathbf{b}^+}{|\mathbf{b}^- \times \mathbf{b}^+|}, \quad (5)$$

and

$$\mathbf{i}_2 = \mathbf{i}_3 \times \mathbf{i}_1. \quad (6)$$

In the coordinate system defined by (4), (6) and (5) we have

$$\mathbf{b}^- = \cos(\Delta/2) \mathbf{i}_1 - \sin(\Delta/2) \mathbf{i}_2 \quad (7)$$

$$\mathbf{b}^+ = \cos(\Delta/2) \mathbf{i}_1 + \sin(\Delta/2) \mathbf{i}_2. \quad (8)$$

3 The Line Filtered Velocity Field

We consider only isotropic turbulence with zero mean velocity. The velocity field in the point

$$\mathbf{x} = x_1 \mathbf{i}_1 + x_2 \mathbf{i}_2 + x_3 \mathbf{i}_3 \quad (9)$$

is

$$\mathbf{u}(\mathbf{x}) = u_1(\mathbf{x}) \mathbf{i}_1 + u_2(\mathbf{x}) \mathbf{i}_2 + u_3(\mathbf{x}) \mathbf{i}_3. \quad (10)$$

The laser anemometer measures the Doppler velocity component v along its beam direction \mathbf{b} with the line weighting function (Smalikho 1995)

$$h(\mu, \lambda) = \frac{1}{\pi R} \frac{\mu}{\mu^2 \left(1 - \frac{\lambda}{R}\right)^2 + 1}, \quad (11)$$

which has its maximum at the distance $\lambda = R$ from the laser and the full width half maximum (FWHM)

$$\ell = 2 \frac{R}{\mu}. \quad (12)$$

Moreover

$$\mu = k_0 a_0^2 / R \quad (13)$$

is a dimensionless parameter expressed in terms of R , the wave number k_0 of the laser light and the exit radius a_0 of the laser aperture. Typical values are $R \sim 100$ m, $k_0 \sim 4 \times 10^6$ m⁻¹, and $a_0 \sim 2 \times 10^{-2}$ m. We thus consider μ to be about 15. In order to be able to carry out the calculations in the following, we replace the range $0 < \lambda < \infty$ by $-\infty < \lambda < \infty$. Indeed the filter (11) is normalized over the latter interval. Kristensen et al. (2011) outlined tools to estimate the normalization error by this approximation. They found it to be about 2% for $\mu = 15$. The width ℓ in (12) can be assumed small compared to R . In fact ℓ is assumed smaller than the velocity integral scale which, in turn, is about the measuring height $R \sin \varphi$ (Kristensen et al. 1989). Therefore the velocity turbulence may be considered locally isotropic. The line filtered velocity is in our approximation

$$v = \int_{-\infty}^{\infty} h(\mu, \lambda) v_0(\lambda) d\lambda, \quad (14)$$

where

$$v_0(\lambda) = \mathbf{b} \cdot \mathbf{u}(\lambda \mathbf{b}), \quad (15)$$

with \mathbf{b} representing \mathbf{b}^- or \mathbf{b}^+ .

In the limit $\mu \rightarrow \infty$ where the filter function is so narrow that the averaging line reduces to a point, we have

$$h(\infty, \lambda) = \delta(\lambda - R) \quad (16)$$

For the two laser-anemometer beams we have

$$v^- = \int_{-\infty}^{\infty} h(\mu, \lambda) v_0^-(\lambda) d\lambda, \quad (17)$$

$$v^+ = \int_{-\infty}^{\infty} h(\mu, \lambda) v_0^+(\lambda) d\lambda, \quad (18)$$

where

$$v_0^-(\lambda) = \mathbf{b}^- \cdot \mathbf{u}(\lambda \mathbf{b}^-) = \cos(\Delta/2) u_1(\lambda \mathbf{b}^-) - \sin(\Delta/2) u_2(\lambda \mathbf{b}^-) \quad (19)$$

$$v_0^+(\lambda) = \mathbf{b}^+ \cdot \mathbf{u}(\lambda \mathbf{b}^+) = \cos(\Delta/2) u_1(\lambda \mathbf{b}^+) + \sin(\Delta/2) u_2(\lambda \mathbf{b}^+). \quad (20)$$

Following Banakh et al. (1999) we want to derive an expression for the line filtered structure function

$$D = \langle (v^+ - v^-)^2 \rangle. \quad (21)$$

This quantity can be written

$$D = \langle v^{-2} \rangle + \langle v^{+2} \rangle - 2\langle v^- v^+ \rangle. \quad (22)$$

We must therefore evaluate

$$\langle v^{-2} \rangle = \int_{-\infty}^{\infty} h(\mu, \lambda') d\lambda' \int_{-\infty}^{\infty} h(\mu, \lambda'') d\lambda'' \langle v_0^-(\lambda') v_0^-(\lambda'') \rangle, \quad (23)$$

$$\langle v^{+2} \rangle = \int_{-\infty}^{\infty} h(\mu, \lambda') d\lambda' \int_{-\infty}^{\infty} h(\mu, \lambda'') d\lambda'' \langle v_0^+(\lambda') v_0^+(\lambda'') \rangle, \quad (24)$$

and

$$\langle v^- v^+ \rangle = \int_{-\infty}^{\infty} h(\mu, \lambda') d\lambda' \int_{-\infty}^{\infty} h(\mu, \lambda'') d\lambda'' \langle v_0^-(\lambda') v_0^+(\lambda'') \rangle. \quad (25)$$

in terms of the maximum point R of $h(\mu, \lambda)$ and the dimensionless filter parameter μ . Defining

$$D_0(\Delta, \lambda', \lambda'') = \langle v_0^-(\lambda') v_0^-(\lambda'') \rangle + \langle v_0^+(\lambda') v_0^+(\lambda'') \rangle - 2\langle v_0^-(\lambda') v_0^+(\lambda'') \rangle, \quad (26)$$

we have

$$D = D(\mu, \Delta) = \int_{-\infty}^{\infty} h(\mu, \lambda') d\lambda' \int_{-\infty}^{\infty} h(\mu, \lambda'') d\lambda'' D_0(\Delta, \lambda', \lambda''). \quad (27)$$

4 Physical Space

We can evaluate (23) – (25) in terms of the covariance tensor $R_{ij}(\mathbf{r}) = \langle u_i(\mathbf{x})u_j(\mathbf{x} + \mathbf{r}) \rangle$ which, in the case of isotropy, can be written

$$R_{ij}(\mathbf{r}) = [R_L(r) - R_T(r)] \frac{r_i r_j}{r^2} + R_T(r) \delta_{ij}, \quad (28)$$

where $r = |\mathbf{r}|$ and $R_L(r)$ and $R_T(r)$ are the longitudinal and lateral covariance, respectively. The relation (28) implies

$$R_{ij}(-\mathbf{r}) = R_{ij}(\mathbf{r}) \quad (29)$$

$$R_{ji}(\mathbf{r}) = R_{ij}(\mathbf{r}) \quad (30)$$

From the relations (19) and (20) it follows that

$$\begin{aligned} \langle v_0^-(\lambda')v_0^-(\lambda'') \rangle &= \cos^2(\Delta/2) R_{11}((\lambda'' - \lambda')\mathbf{b}^-) + \sin^2(\Delta/2) R_{22}((\lambda'' - \lambda')\mathbf{b}^-) \\ &\quad - 2 \cos(\Delta/2) \sin(\Delta/2) R_{12}((\lambda'' - \lambda')\mathbf{b}^-), \end{aligned} \quad (31)$$

$$\begin{aligned} \langle v_0^+(\lambda')v_0^+(\lambda'') \rangle &= \cos^2(\Delta/2) R_{11}((\lambda'' - \lambda')\mathbf{b}^+) + \sin^2(\Delta/2) R_{22}((\lambda'' - \lambda')\mathbf{b}^+) \\ &\quad + 2 \cos(\Delta/2) \sin(\Delta/2) R_{12}((\lambda'' - \lambda')\mathbf{b}^+), \end{aligned} \quad (32)$$

and

$$\begin{aligned} \langle v_0^-(\lambda')v_0^+(\lambda'') \rangle \\ &= \cos^2(\Delta/2) R_{11}(\lambda''\mathbf{b}^+ - \lambda'\mathbf{b}^-) - \sin^2(\Delta/2) R_{22}(\lambda''\mathbf{b}^+ - \lambda'\mathbf{b}^-). \end{aligned} \quad (33)$$

Using (28) we obtain

$$\langle v_0^-(\lambda')v_0^-(\lambda'') \rangle = \langle v_0^+(\lambda')v_0^+(\lambda'') \rangle = R_L(|\lambda'' - \lambda'|). \quad (34)$$

It takes a little more effort to evaluate (33). We note that the argument in R_{11} and R_{22} is

$$\mathbf{r}(\lambda', \lambda'') \equiv \lambda''\mathbf{b}^+ - \lambda'\mathbf{b}^- = (\lambda'' - \lambda') \cos(\Delta/2) \mathbf{i}_1 + (\lambda' + \lambda'') \sin(\Delta/2) \mathbf{i}_2 \quad (35)$$

and, consequently,

$$r^2(\lambda', \lambda'') = (\lambda'' - \lambda')^2 + 4\lambda'\lambda'' \sin^2(\Delta/2). \quad (36)$$

By use of (28) and (35) we get

$$\begin{aligned}
\langle v_0^-(\lambda')v_0^+(\lambda'') \rangle = & \\
& [R_L(r(\lambda', \lambda'')) - R_T(r(\lambda', \lambda''))] \frac{(\lambda'' - \lambda')^2 \cos^4(\Delta/2) - (\lambda' + \lambda'')^2 \sin^4(\Delta/2)}{r^2(\lambda', \lambda'')} \\
& + R_T(r(\lambda', \lambda''))[\cos^2(\Delta/2) - \sin^2(\Delta/2)]. \tag{37}
\end{aligned}$$

This equation can be re-arranged to become

$$\begin{aligned}
\langle v_0^-(\lambda')v_0^+(\lambda'') \rangle = R_L(r(\lambda', \lambda'')) \cos \Delta - & \\
& [R_L(r(\lambda', \lambda'')) - R_T(r(\lambda', \lambda''))] \frac{\lambda'\lambda'' \sin^2 \Delta}{(\lambda'' - \lambda')^2 + 4\lambda'\lambda'' \sin^2(\Delta/2)}. \tag{38}
\end{aligned}$$

Inserting (34) and (38) in (26) we get

$$\begin{aligned}
D_0(\Delta, \lambda', \lambda'') = & 2[R_L(|\lambda'' - \lambda'|) - R_L(r(\lambda', \lambda'')) \cos \Delta] \\
& + 2[R_L(r(\lambda', \lambda'')) - R_T(r(\lambda', \lambda''))] \frac{\lambda'\lambda'' \sin^2 \Delta}{(\lambda'' - \lambda')^2 + 4\lambda'\lambda'' \sin^2(\Delta/2)}. \tag{39}
\end{aligned}$$

We wish to express (39) in terms of the structure functions

$$D_L(\rho) = 2[R_L(0) - R_L(\rho)] \tag{40}$$

and

$$D_T(\rho) = 2[R_T(0) - R_T(\rho)], \tag{41}$$

where $R_L(0) = R_T(0)$ are the variance of one velocity component. The equivalent to (39) then becomes

$$\begin{aligned}
D_0(\Delta, \lambda', \lambda'') = & 2(1 - \cos \Delta) R_L(0) + D_L(r(\lambda', \lambda'')) \cos \Delta - D_L(|\lambda'' - \lambda'|) \\
& + [D_T(r(\lambda', \lambda'')) - D_L(r(\lambda', \lambda''))] \frac{\lambda'\lambda'' \sin^2 \Delta}{(\lambda'' - \lambda')^2 + 4\lambda'\lambda'' \sin^2(\Delta/2)}. \tag{42}
\end{aligned}$$

We may now apply the standard expressions for the structure function for locally isotropic turbulence. They are

$$D_L(r) = \frac{27}{55} \Gamma\left(\frac{1}{3}\right) \alpha \varepsilon^{2/3} r^{2/3} \tag{43}$$

and

$$D_T(r) = \frac{36}{55} \Gamma\left(\frac{1}{3}\right) \alpha \varepsilon^{2/3} r^{2/3}, \quad (44)$$

where ε is the rate of destruction of specific kinetic energy, also just called the dissipation, and α the Kolmogorov constant. According to Kristensen et al. (1989) this constant is approximately 1.7. Inserting (43) and (44) with r given by (36), (42) can be written

$$\begin{aligned} D_0(\Delta, \lambda', \lambda'') &= 2(1 - \cos \Delta) R_L(0) \\ &+ \frac{9}{55} \Gamma\left(\frac{1}{3}\right) \alpha \varepsilon^{2/3} \left\{ 3 \left[[(\lambda'' - \lambda')^2 + 4 \lambda' \lambda'' \sin^2(\Delta/2)]^{1/3} \cos \Delta - |\lambda'' - \lambda'|^{2/3} \right] \right. \\ &\left. + \frac{\lambda' \lambda'' \sin^2 \Delta}{[(\lambda'' - \lambda')^2 + 4 \lambda' \lambda'' \sin^2(\Delta/2)]^{2/3}} \right\}. \end{aligned} \quad (45)$$

Introducing the dimensionless integration variables $\xi' = \lambda'/R$ and $\xi'' = \lambda''/R$ in (27) we get

$$\begin{aligned} D(\mu, \Delta) &= 2(1 - \cos \Delta) R_L(0) \\ &+ \frac{9}{55} \Gamma\left(\frac{1}{3}\right) \alpha (\varepsilon R)^{2/3} \int_{-\infty}^{\infty} h^*(\mu, \xi') d\xi' \int_{-\infty}^{\infty} h^*(\mu, \xi'') d\xi'' \\ &\times \left\{ 3 \left[[(\xi'' - \xi')^2 + 4 \xi' \xi'' \sin^2(\Delta/2)]^{1/3} \cos \Delta - |\xi'' - \xi'|^{2/3} \right] \right. \\ &\left. + \frac{\xi' \xi'' \sin^2 \Delta}{[(\xi'' - \xi')^2 + 4 \xi' \xi'' \sin^2(\Delta/2)]^{2/3}} \right\}, \end{aligned} \quad (46)$$

where

$$h^*(\mu, x) \equiv Rh(\mu, Rx) = \frac{1}{\pi} \frac{\mu}{\mu^2(1-x)^2 + 1}. \quad (47)$$

In the point limit $\mu \rightarrow \infty$ we can use (16) in the form $h^*(\infty, \xi) = \delta(\xi - 1)$ which gives

$$\begin{aligned} D(\infty, \Delta) &= 2(1 - \cos \Delta) R_L(0) \\ &+ \frac{36}{55} \Gamma\left(\frac{1}{3}\right) \alpha \varepsilon^{2/3} (2R \sin(\Delta/2))^{2/3} \frac{1 + 7 \cos \Delta}{8} \end{aligned} \quad (48)$$

When $\Delta \ll 1$ the second term on the right-hand side approaches

$$D_T(R\Delta) = \frac{36}{55} \Gamma\left(\frac{1}{3}\right) \alpha \varepsilon^{2/3} (R\Delta)^{2/3} \quad (49)$$

which is just the structure function of the velocity component perpendicular to the displacement vector given by (44). This part is not surprising. The first term is a correction for the two displaced velocity components for not being quite parallel, but forming the angle Δ with one another.

There is no simple and general theory for the determination of the variance $R_L(0)$. It can only be estimated empirically on basis of experimental field observations e.g., data from the so-called Minnesota experiment (Haugen et al. 1971). We return to this subject in section 6.

It is practical to introduce the normalized structure function

$$D^*(\mu, \Delta) = \frac{D(\mu, \Delta) - 2(1 - \cos \Delta) R_L(0)}{\alpha(\varepsilon R)^{2/3}}. \quad (50)$$

We showed in Kristensen et al. (2011) that if the laser beams were parallel the structure function would up to second order in Δ be a sum of a term proportional to $\Delta^{5/3}$ and of a term proportional to Δ^2 . This leads us to the conjecture that (50) up to second order in Δ^2 can be written

$$D^*(\mu, \Delta) = a(\mu)\Delta^{5/3} + b(\mu)\Delta^2. \quad (51)$$

This conjecture is confirmed in appendix A. Here it is shown that $D^*(\mu, \Delta)$ for small Δ has this asymptotic expansion with the coefficients given by

$$a(\mu) = \frac{\Gamma^2(1/6) (1 + \mu^2)^{1/3}}{50\pi (2\mu)^{2/3}} [(2\sqrt{3} + 9\mu)\cos(v(\mu)) - 3(\sqrt{3}\mu - 2)\sin(v(\mu))], \quad (52)$$

where

$$v(\mu) = \frac{2}{3} \operatorname{arccot}(\mu) \quad (53)$$

and

$$b(\mu) = -\frac{9}{55} \Gamma(1/3) \frac{4 + \mu^2}{(\mu/2)^{2/3}}. \quad (54)$$

When μ is large the following applies to (52)

$$a(\mu) \approx \frac{9\Gamma^2(1/6)}{50\pi 2^{2/3}} \mu. \quad (55)$$

For $\mu = 16$ the error by using (55) instead of (52) is about 0.2 %.

5 Wave-Number Space

Our main result (46) is a complicated double integral and its evaluation is, from a practical point of view, rather problematic. However, we shall formulate the same result as integration in wave-number space with the advantage that the final numerical integration is essentially just a single integral. This admits a much faster and more reliable evaluation of $D^*(\mu, \Delta)$. First we note that

$$R_{ij}(\boldsymbol{\rho}) = \int_{-\infty}^{\infty} dk_1 \int_{-\infty}^{\infty} dk_2 \int_{-\infty}^{\infty} dk_3 \Phi_{ij}(\mathbf{k}) e^{i\mathbf{k}\cdot\boldsymbol{\rho}}, \quad (56)$$

where

$$\Phi_{ij}(\mathbf{k}) = \frac{E(k)}{4\pi k^4} [k^2 \delta_{ij} - k_i k_j] \quad (57)$$

is the spectral tensor for isotropic turbulence. Here we cannot use the common expression for the streamwise velocity spectrum, pertaining to local isotropy,

$$F_L(k) = \frac{9}{55} \alpha \varepsilon^{2/3} k^{-5/3} \quad (58)$$

because it is not bounded when $k \rightarrow 0$. Instead we shall use the von Kármán spectrum (von Kármán 1948)

$$F_L(k) = \frac{9}{55} \frac{\alpha \varepsilon^{2/3}}{(q^2 + k^2)^{5/6}}, \quad (59)$$

where q is a wave number characterizing the integral turbulence scale. This spectrum is not based on physical observations but is used only for mathematical convenience. It is finite for all wave numbers and coincides with (58) in the inertial subrange, and this is all what is needed for the following analysis. We use the relation

$$E(k) = k^3 \frac{d}{dk} \left(\frac{1}{k} \frac{dF_L}{dk} \right) \quad (60)$$

to obtain the corresponding energy spectrum

$$E(k) = \alpha \varepsilon^{2/3} \frac{k^4}{(q^2 + k^2)^{17/6}}. \quad (61)$$

We note that the variance of the longitudinal velocity component $R_L(0)$ is obtained by integrating (59) with the result

$$R_L(0) = \int_{-\infty}^{\infty} F_L(k) dk = \frac{9}{55} B(1/2, 1/3) \frac{\alpha \varepsilon^{2/3}}{q^{2/3}}, \quad (62)$$

where $B(m, n) = \Gamma(m)\Gamma(n)/\Gamma(m+n)$ is the beta function.

We go back to (31)–(33) and note that we need to consider only the combinations $(i, j) = (1, 1)$ and $(i, j) = (2, 2)$. Further, we need not to consider k_3 in the exponential since neither \mathbf{b}^- nor \mathbf{b}^+ contains \mathbf{i}_3 . This means that the triple integral (56) can be reduced to a double integral for $R_{11}(\boldsymbol{\rho})$, $R_{22}(\boldsymbol{\rho})$, and $R_{12}(\boldsymbol{\rho})$. In other words,

$$\begin{aligned} R_{11}(\boldsymbol{\rho}) &= \frac{\alpha \varepsilon^{2/3}}{4\pi} \int_{-\infty}^{\infty} dk_1 \int_{-\infty}^{\infty} dk_2 e^{i\mathbf{k}\cdot\boldsymbol{\rho}} \int_{-\infty}^{\infty} \frac{k_2^2 + k_3^2}{(q^2 + k_1^2 + k_2^2 + k_3^2)^{17/6}} dk_3 \\ &= \frac{2}{55} B(1/2, 1/3) \frac{\alpha \varepsilon^{2/3}}{4\pi} \int_{-\infty}^{\infty} dk_1 \int_{-\infty}^{\infty} dk_2 \frac{3q^2 + 3k_1^2 + 11k_2^2}{(q^2 + k_1^2 + k_2^2)^{7/3}} e^{i\mathbf{k}\cdot\boldsymbol{\rho}}, \end{aligned} \quad (63)$$

$$\begin{aligned}
R_{22}(\boldsymbol{\rho}) &= \frac{\alpha \varepsilon^{2/3}}{4\pi} \int_{-\infty}^{\infty} dk_1 \int_{-\infty}^{\infty} dk_2 e^{i\mathbf{k}\cdot\boldsymbol{\rho}} \int_{-\infty}^{\infty} \frac{k_1^2 + k_3^2}{(q^2 + k_1^2 + k_2^2 + k_3^2)^{17/6}} dk_3 \\
&= \frac{2}{55} B(1/2, 1/3) \frac{\alpha \varepsilon^{2/3}}{4\pi} \int_{-\infty}^{\infty} dk_1 \int_{-\infty}^{\infty} dk_2 \frac{3q^2 + 11k_1^2 + 3k_2^2}{(q^2 + k_1^2 + k_2^2)^{7/3}} e^{i\mathbf{k}\cdot\boldsymbol{\rho}}, \quad (64)
\end{aligned}$$

and

$$\begin{aligned}
R_{12}(\boldsymbol{\rho}) &= -\frac{\alpha \varepsilon^{2/3}}{4\pi} \int_{-\infty}^{\infty} dk_1 \int_{-\infty}^{\infty} dk_2 e^{i\mathbf{k}\cdot\boldsymbol{\rho}} \int_{-\infty}^{\infty} \frac{k_1 k_2}{(q^2 + k_1^2 + k_2^2 + k_3^2)^{17/6}} dk_3 \\
&= -\frac{16}{55} B(1/2, 1/3) \frac{\alpha \varepsilon^{2/3}}{4\pi} \int_{-\infty}^{\infty} dk_1 \int_{-\infty}^{\infty} dk_2 \frac{k_1 k_2}{(q^2 + k_1^2 + k_2^2)^{7/3}} e^{i\mathbf{k}\cdot\boldsymbol{\rho}}. \quad (65)
\end{aligned}$$

Details in the derivation are given in Appendix B.

Introducing the dimensionless parameters

$$Q = qR \quad (66)$$

and

$$K = \kappa R \quad (67)$$

(B 29) and (B 30), in view of $\ell = 2R/\mu$, become

$$\begin{aligned}
\langle v^2 \rangle &= \alpha (\varepsilon R)^{2/3} \frac{4}{55} B(1/2, 1/3) \int_0^{\infty} \frac{K dK}{(Q^2 + K^2)^{7/3}} \\
&\quad \times \frac{1}{2\pi} \int_0^{\pi/2} (3Q^2 + 7K^2 - 4K^2 \cos(2\theta)) \exp\left(-\frac{2K}{\mu} \cos\theta\right) d\theta, \quad (68)
\end{aligned}$$

and

$$\begin{aligned}
\langle v^- v^+ \rangle &= \alpha (\varepsilon R)^{2/3} \frac{4}{55} B(1/2, 1/3) \int_0^{\infty} \frac{K dK}{(Q^2 + K^2)^{7/3}} \\
&\quad \times \frac{1}{2\pi} \int_0^{\pi/2} ((3Q^2 + 7K^2) \cos \Delta - 4K^2 \cos(2\theta)) \cos(2K \sin \theta \sin(\Delta/2))
\end{aligned}$$

$$\exp\left(-\frac{K}{\mu} \{|\cos(\theta + \Delta/2)| + |\cos(\theta - \Delta/2)|\}\right) d\theta. \quad (69)$$

It would be informative to check if the equations (B 27)–(B 30), combined by (22) to the final result, in the case of point measurements are consistent with (48). In other words, we let $\ell \rightarrow 0$ and $\mu\ell = 2R$. The variances (B 27) and (B 28) become, not surprisingly,

$$\begin{aligned} \lim_{\mu \rightarrow \infty} \langle v^2 \rangle &= \alpha(\varepsilon R)^{2/3} \frac{4}{55} B(1/2, 1/3) \int_0^\infty \frac{K dK}{(Q^2 + K^2)^{7/3}} \frac{1}{2\pi} \int_0^{\pi/2} (3Q^2 + 7K^2) d\theta \\ &= \frac{9}{55} B(1/2, 1/3) \frac{\alpha(\varepsilon R)^{2/3}}{Q^{2/3}} = \frac{9}{55} B(1/2, 1/3) \frac{\alpha \varepsilon^{2/3}}{q^{2/3}} = R_L(0) \end{aligned} \quad (70)$$

according to (62). We can now write

$$\begin{aligned} \langle v^2 \rangle &= \lim_{\mu \rightarrow \infty} \langle v^2 \rangle + (\langle v^2 \rangle - \lim_{\mu \rightarrow \infty} \langle v^2 \rangle) \\ &= R_L(0) - \alpha(\varepsilon R)^{2/3} \frac{4}{55} B(1/2, 1/3) \int_0^\infty \frac{K dK}{(Q^2 + K^2)^{7/3}} \\ &\quad \times \frac{1}{2\pi} \int_0^{\pi/2} [3Q^2 + 7K^2 - 4K^2 \cos(2\theta)] \left[1 - \exp\left(-\frac{2K}{\mu} \cos \theta\right)\right] d\theta \end{aligned} \quad (71)$$

The last term pertains to the small-scale, locally isotropic turbulence and we then let Q , which is a dimensionless wave-number measure of the large-scale turbulence, be zero. We thus conclude that

$$\langle v^2 \rangle = R_L(0) - \alpha(\varepsilon R)^{2/3} \frac{27}{55} \Gamma\left(\frac{1}{3}\right) \left(\frac{\mu}{2}\right)^{-2/3}. \quad (72)$$

The corresponding result for (69) is

$$\begin{aligned} \lim_{\mu \rightarrow \infty} \langle v^- v^+ \rangle &= \alpha(\varepsilon R)^{2/3} \frac{4}{55} B(1/2, 1/3) \int_0^\infty \frac{K dK}{(Q^2 + K^2)^{7/3}} \\ &\quad \times \frac{1}{2\pi} \int_0^{\pi/2} ((3Q^2 + 7K^2) \cos \Delta - 4K^2 \cos(2\theta)) \cos(2K \sin \theta \sin(\Delta/2)) d\theta = \\ &\quad \alpha(\varepsilon R)^{2/3} \frac{2}{55} \frac{B(1/2, 1/3)}{\Gamma(7/3)} Q^{-1/3} \sin^{1/3}(\Delta/2) \\ &\quad \times \{4K_{1/3}(2Q \sin(\Delta/2)) \cos \Delta - Q[\sin(\Delta/2) + \sin(3\Delta/2)] K_{2/3}(2Q \sin(\Delta/2))\}. \end{aligned} \quad (73)$$

Here $K_\nu(x)$ is the modified Bessel Function of the second kind. For assumed small values of Q and finite values of Δ we can expand (73) in a power series in Q . This results in the following expression

$$\begin{aligned} \lim_{\mu \rightarrow \infty} \langle v^- v^+ \rangle &= \frac{9}{55} B\left(\frac{1}{2}, \frac{1}{3}\right) \alpha \varepsilon^{2/3} \cos \Delta q^{-2/3} \\ &- \frac{18}{55} \Gamma\left(\frac{1}{3}\right) \alpha \varepsilon^{2/3} (2R \sin(\Delta/2))^{2/3} \frac{1+7 \cos \Delta}{8} + \mathcal{O}(q^{4/3}). \end{aligned} \quad (74)$$

We use (62) on the first term on the right-hand side and clear the $\mathcal{O}(q^{4/3})$ -term to zero:

$$\begin{aligned} \lim_{\mu \rightarrow \infty} \langle v^- v^+ \rangle &= R_L(0) \cos \Delta \\ &- \alpha (\varepsilon R)^{2/3} \frac{18}{55} \Gamma\left(\frac{1}{3}\right) (2R \sin(\Delta/2))^{2/3} \frac{1+7 \cos \Delta}{8} \end{aligned} \quad (75)$$

Inserting (75) together with (70) in (22), we retrieve the formula (48) for point measurements.

We may now evaluate $\langle v^- v^+ \rangle$ by determining the residual $\lim_{\mu \rightarrow \infty} \langle v^- v^+ \rangle - \langle v^- v^+ \rangle$. We have from (69) and the first equation of (73)

$$\begin{aligned} \lim_{\mu \rightarrow \infty} \langle v^- v^+ \rangle - \langle v^- v^+ \rangle &= \alpha (\varepsilon R)^{2/3} \frac{4}{55} B(1/2, 1/3) \int_0^\infty \frac{K dK}{(Q^2 + K^2)^{7/3}} \\ &\times \frac{1}{2\pi} \int_0^{\pi/2} ((3Q^2 + 7K^2) \cos \Delta - 4K^2 \cos(2\theta)) \cos(2K \sin \theta \sin(\Delta/2)) \\ &\left\{ 1 - \exp\left(-\frac{K}{\mu} \{|\cos(\theta + \Delta/2)| + |\cos(\theta - \Delta/2)|\}\right) \right\} d\theta. \end{aligned} \quad (76)$$

This double integral is convergent in the limit $Q = 0$, corresponding to local isotropy, and it can be shown that in this case it can be reduced to a single integral over θ . We have

$$\lim_{\mu \rightarrow \infty} \langle v^- v^+ \rangle - \langle v^- v^+ \rangle = \alpha (\varepsilon R)^{2/3} \frac{3}{55} \Gamma\left(\frac{1}{3}\right) \mu^{-2/3} \frac{1}{2\pi} \int_0^{\pi/2} G(\mu, \Delta, \theta) d\theta, \quad (77)$$

where

$$\begin{aligned}
G(\mu, \Delta, \theta) &= B(1/2, 1/3) (7 \cos \Delta - 4 \cos(2\theta)) \\
&\times \left\{ 2 \cos \left(\frac{2}{3} \arctan \left(\frac{2\mu \sin(\Delta/2) \sin \theta}{|\cos(\theta + \Delta/2)| + |\cos(\theta - \Delta/2)|} \right) \right) \right. \\
&\times \left[(|\cos(\theta + \Delta/2)| + |\cos(\theta - \Delta/2)|)^2 + 4\mu^2 \sin^2(\Delta/2) \sin^2 \theta \right]^{1/3} \\
&\left. - [2\mu \sin(\Delta/2) \sin \theta]^{2/3} \right\}. \tag{78}
\end{aligned}$$

We can now obtain an expression for $D(\mu, \Delta)$ by collecting terms as follows. First we rewrite (22) to

$$D = 2(\langle v^2 \rangle - \langle v^- v^+ \rangle). \tag{79}$$

The first term inside the parenthesis is given by (72). The second is determined by reformulating (77) as

$$\langle v^- v^+ \rangle = \lim_{\mu \rightarrow \infty} \langle v^- v^+ \rangle - \alpha(\varepsilon R)^{2/3} \frac{3}{55} \Gamma(1/3) \mu^{-2/3} \frac{1}{2\pi} \int_0^{\pi/2} G(\mu, \Delta, \theta) d\theta. \tag{80}$$

Here the first term on the right-hand side is given by (75) so that

$$\begin{aligned}
\langle v^- v^+ \rangle &= R_L(0) \cos \Delta - \alpha(\varepsilon R)^{2/3} \frac{3}{55} \Gamma(1/3) \left\{ \frac{3}{2^{4/3}} (1 + 7 \cos \Delta) \sin^{2/3}(\Delta/2) \right. \\
&\left. + \frac{\mu^{-2/3}}{2\pi} \int_0^{\pi/2} G(\mu, \Delta, \theta) d\theta \right\}. \tag{81}
\end{aligned}$$

Finally we get

$$\begin{aligned}
D(\mu, \Delta) &= 2(1 - \cos \Delta) R_L(0) + \alpha(\varepsilon R)^{2/3} \frac{3}{55} \Gamma\left(\frac{1}{3}\right) \\
&\times \left\{ \frac{3}{2^{1/3}} (1 + 7 \cos \Delta) \sin^{2/3}(\Delta/2) - 18 \left(\frac{\mu}{2}\right)^{-2/3} + \frac{\mu^{-2/3}}{\pi} \int_0^{\pi/2} G(\mu, \Delta, \theta) d\theta \right\} \tag{82}
\end{aligned}$$

or, reformulated by (50),

$$D^*(\mu, \Delta) = \frac{3}{55} \Gamma\left(\frac{1}{3}\right) \times \left\{ \frac{3}{2^{1/3}} (1 + 7 \cos \Delta) \sin^{2/3}(\Delta/2) - 18 \left(\frac{\mu}{2}\right)^{-2/3} + \frac{\mu^{-2/3}}{\pi} \int_0^{\pi/2} G(\mu, \Delta, \theta) d\theta \right\}. \quad (83)$$

Again, the limiting result to the second order in Δ and $\ell \rightarrow 0$ becomes identical to (48). Numerical experiments confirm that (83) with (78) and $D^*(\mu, \Delta)$ derived from (46) and (50) are indeed equivalent. For computational purposes use of (78) and (83) is the better choice, since the single integral gives faster and more reliable numerical results. However, a certain computational precision is needed because there is a good deal of cancellation among the terms in (83).

6 Discussion

The one-component variance $R_L(0)$ must be estimated separately because the structure-function formulation implies that $R_L(0)$ relates to eddies larger than those which can be considered locally isotropic. Consequently, we must use semi-empirical equations based on observational studies and consider the variance of the vertical velocity as representing $R_L(0)$. For calm conditions with no mean wind the atmosphere is very convective in which case the convective velocity scale w_* can be related to the variance and the dissipation. Following Kristensen et al. (1989) we have

$$w_* = \left\{ \frac{g}{T} \langle w\vartheta \rangle_0 h \right\}^{1/3}. \quad (84)$$

Here g/T , combining the acceleration of gravity and the atmospheric temperature (in $^\circ K$), is the buoyancy parameter, $\langle w\vartheta \rangle_0$ the vertical turbulent flux of potential temperature, and h the height of the convective boundary layer. Kristensen et al. (1989) have compiled the relevant empirical relations. Assuming that the measuring height z is much smaller than h we find that

$$\varepsilon \simeq 0.75 \frac{w_*^3}{h} \quad (85)$$

and

$$R_L(0) \simeq 1.44 w_*^2 \left(\frac{z}{h}\right)^{2/3} \simeq 1.3 w_*^2 \left(\frac{R}{h}\right)^{2/3}. \quad (86)$$

Here we have assumed that the inclination angle is $\varphi = 60^\circ$ so that $z = R \sin \varphi \simeq 0.87R$. Combining (85) and (86) we get

$$R_L(0) \simeq 1.6 (\varepsilon R)^{2/3}. \quad (87)$$

Banakh et al. (1999) arrived at an expression corresponding to (46). Their result for $\Delta \ll 1$ can, in the notation used here, be written

$$D(\mu, \Delta) = \sigma_e^2 + C_K(\varepsilon R)^{2/3} \int_0^\infty h^*(\mu, \xi') d\xi' \int_0^\infty h^*(\mu, \xi'') d\xi''$$

$$\times \left\{ ((\xi'' - \xi')^2 + \xi' \xi'' \Delta^2)^{1/3} - |\xi'' - \xi'|^{2/3} + \frac{1}{3} \frac{\xi' \xi'' \Delta^2}{((\xi'' - \xi')^2 + \xi' \xi'' \Delta^2)^{2/3}} \right\}, \quad (88)$$

where Banakh et al. (1999) identify $C_K = 2$ as the Kolmogorov constant*.

By a suitable reformulation in the case $\Delta \ll 1$ our result (46) can be written (Appendix A)

$$D(\mu, \Delta) = R_L(0) \Delta^2$$

$$+ \frac{27}{55} \Gamma\left(\frac{1}{3}\right) \alpha(\varepsilon R)^{2/3} \int_{-\infty}^\infty h^*(\mu, \xi') d\xi' \int_{-\infty}^\infty h^*(\mu, \xi'') d\xi''$$

$$\times \left\{ ((\xi'' - \xi')^2 + \xi' \xi'' \Delta^2)^{1/3} - |\xi'' - \xi'|^{2/3} + \frac{1}{3} \frac{(\xi' \xi'' - \frac{3}{2} (\xi'' - \xi')^2) \Delta^2}{((\xi'' - \xi')^2 + \xi' \xi'' \Delta^2)^{2/3}} \right\}, \quad (89)$$

Comparing (88) to (89), where in both cases $h^*(\mu, \xi)$ is given by (47), there is one significant difference: Banakh et al. (1999) have neglected the term $R_L(0) \Delta^2$ which is zero only when Δ is zero. They have included, however, a term σ_e^2 which is an estimate of the random error of the measured wind speed due to fluctuations of the photo current in the detector. We have not included a similar term. Another difference is that in the integrand they have missed the term $-\frac{3}{2} (\xi'' - \xi')^2$ in the parenthesis in the numerator of the last term. Also, a more detailed comparison would require that we in (89) correctly replace the lower limits $-\infty$ in the integrals by zero. This would be relevant if μ is very small so that the integrand stretches far into second and fourth quadrant in the $\xi' - \xi''$ plane thus causing $D^*(\mu, \Delta)$, defined by (50), to become negative. For example, Fig. 6 in the last section shows that for $\Delta = 0.4 \simeq 23^\circ$ $D^*(\mu, \Delta)$ is negative when $\mu < 2$.

7 Results

We have determined $D^*(\mu, \Delta)$ by inserting 4 typical values of μ in (83). The one-dimensional integral is in each case carried out in a range of Δ from 0.001 to 0.1. The result is shown in Fig. 3 together with the asymptotic result (51). We note that this result falls slightly below $D^*(\mu, \Delta)$ given by (83) for the larger values of Δ . To illustrate this more directly we have determined the relative deviation defined as

$$\chi(\mu, \Delta) = [D^*(\mu, \Delta)_{\text{eq.83}} - D^*(\mu, \Delta)_{\text{eq.51}}] / D^*(\mu, \Delta)_{\text{eq.83}}, \quad (90)$$

which is displayed as functions of Δ for $\mu = 5, 10, 15,$ and 20 . We note that $\chi(\mu, \Delta)$ increases with both μ and Δ . A contour plot of $\chi(\mu, \Delta)$ is shown in Fig. 5.

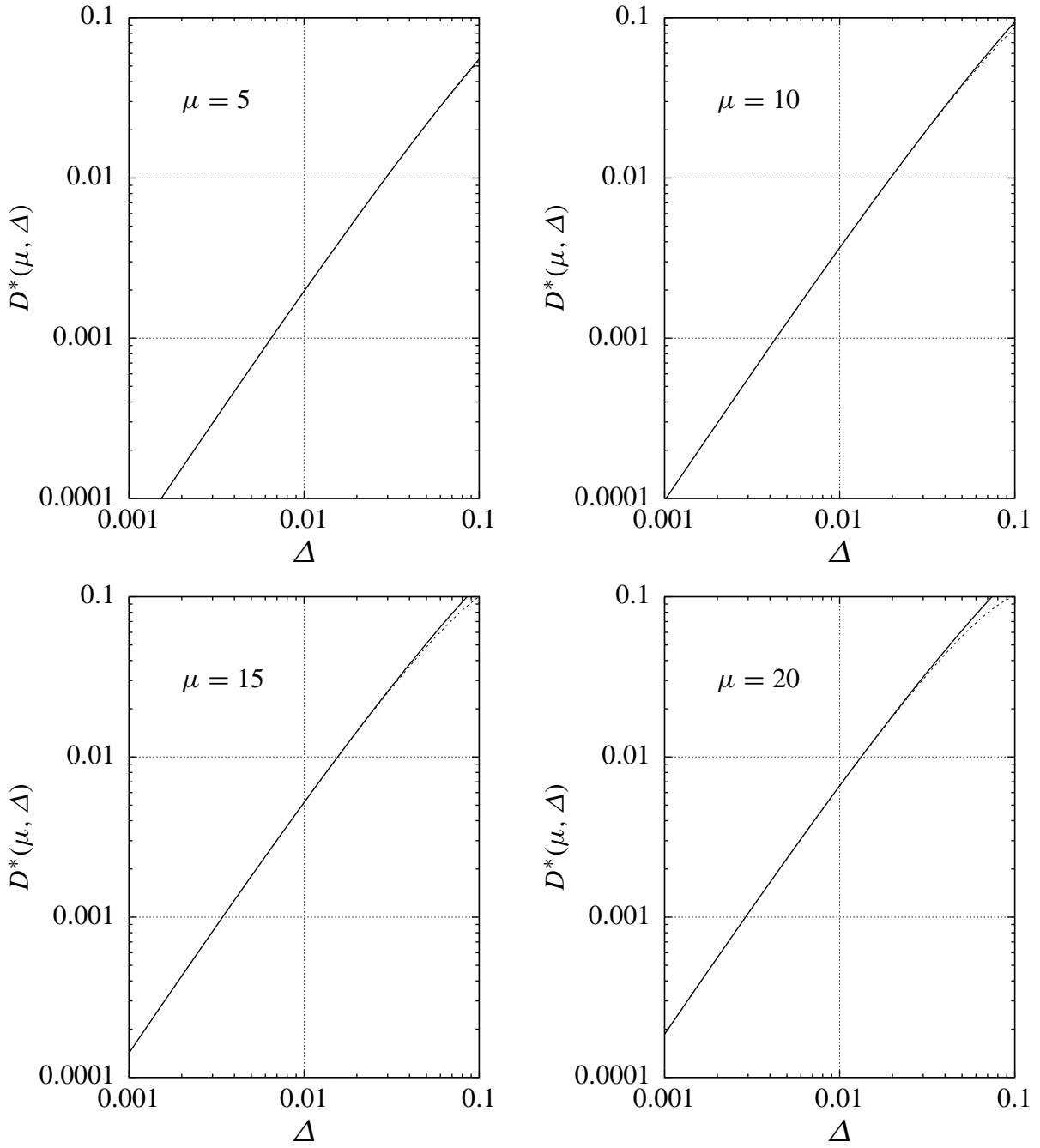

Figure 3. $D^*(\mu, \Delta)$ defined by (50) for four values of μ . The solid line corresponds to (83) and the dotted lines to (51).

A more detailed study of (83) shows that this expression can become negative when μ is sufficiently small. It is worthwhile remembering, as shown by (12), that small values of μ means that the width of the filter ℓ is larger than the distance R to the center of the measuring volume. So this peculiarity is hardly of any practical importance. However, we illustrate in Fig. 6 where in the μ - Δ plane the zero line is. We see that for a given small value of μ there is an upper limit for Δ to obtain meaningful results. In this connection it should be emphasized that the structure function cannot be negative, as the definition (21) shows.

*We maintain that the Kolmogorov constant $\alpha \simeq 1.7$ pertains to the energy spectrum for locally isotropic turbulence and suspect that they also find $C_K = 27/55 \Gamma(1/3) \alpha \simeq 2.2$.

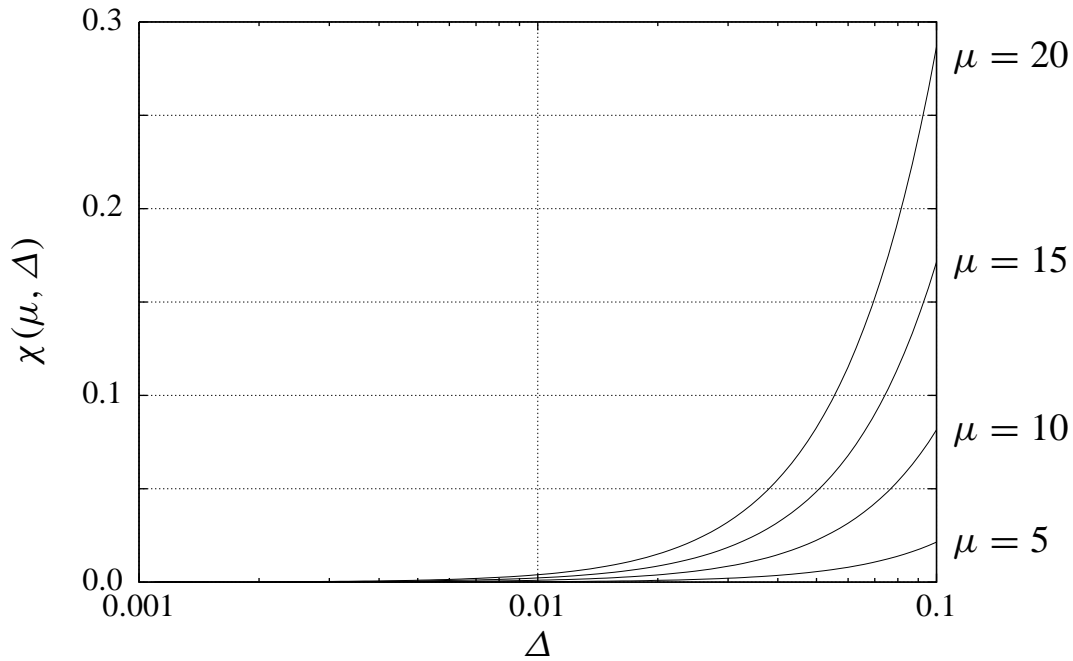

Figure 4. The relative deviation $(D^*(\mu, \Delta)_{\text{eq.83}} - D^*(\mu, \Delta)_{\text{eq.51}})/D^*(\mu, \Delta)_{\text{eq.83}}$ for selected values of μ .

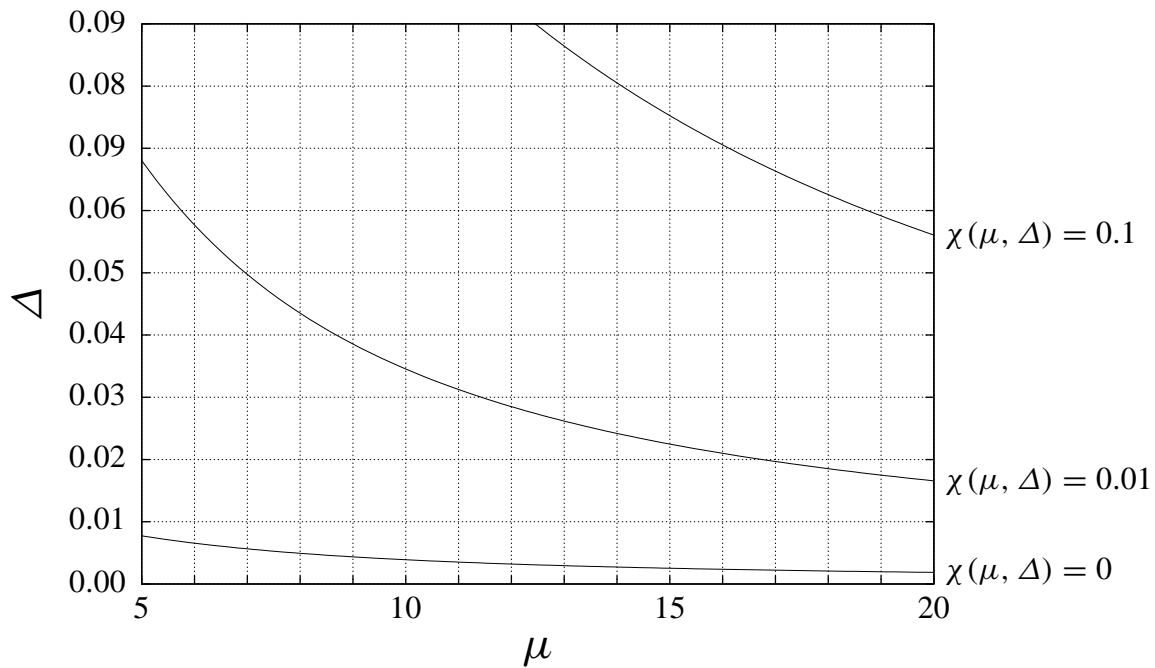

Figure 5. Contour plot of $\chi(\mu, \Delta)$.

8 Conclusion

We have, in much detail, derived equations for the determination of the velocity structure function as measured by one CW-laser anemometer operating in VAD-mode. This method is useful when the mean-wind speed is zero or very small which may occur un-

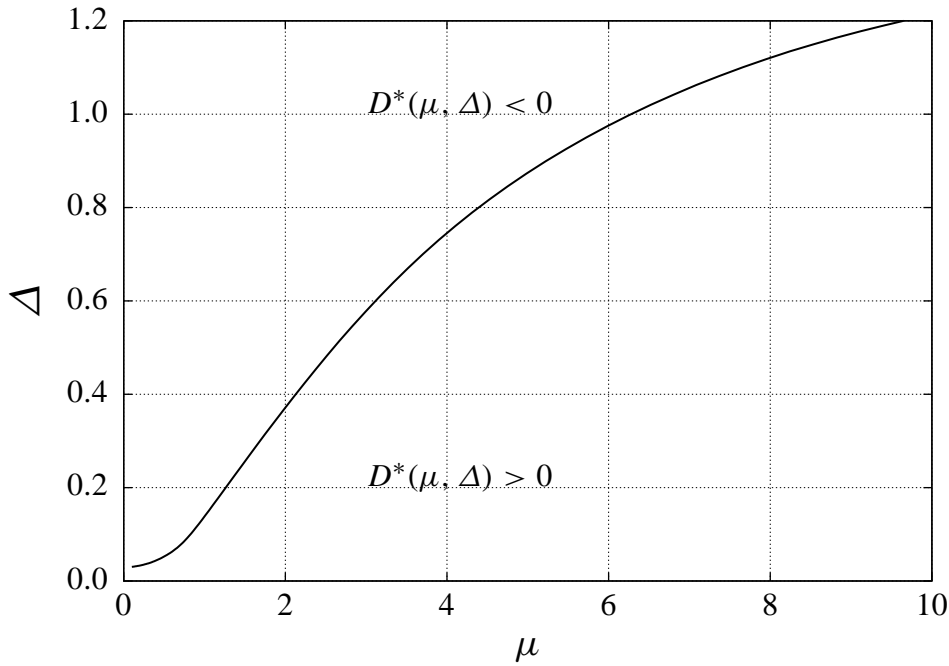

Figure 6. Zero line for $D^*(\mu, \Delta)$ determined from the numerical calculation of (83).

der very convective situations. One very important point is that the measured structure function consists of two terms, one containing the large scale turbulence, namely the total variance, and the small scale term. The first term must be determined separately by other means. We have derived two equivalent expressions for this small-scale structure function, which have the important dimensionless parameter $\mu = 2R/\ell$, where R is the distance from the laser to the center of the weighing function and ℓ is the width (FWHM) of this function. The first involves a double integration in physical space. However, it is difficult to obtain accurate integration results. By transforming the equations to wave-number space by a simple Fourier transform we obtained an alternative formulation which essentially consists of a single integration. The numerical integration in this case leads to accurate and reliable results. It was shown that for an angle Δ between the two beams smaller than about $0.02 \simeq 1^\circ$ it is possible to use a simple equation for the small-scale part of the structure function. It is given as the sum of two terms, one proportional to $\Delta^{2/3}$ and one proportional to Δ^2 . The corresponding coefficients are simple functions of $\mu = 2R/\ell$.

Appendices

A Physical Space, Details

We shall first give a justification of how (89) is obtained from (27) and (45), assuming $\Delta \ll 1$. It would not work just to expand $D_0(\Delta, \lambda', \lambda'')$ in a Taylor series in Δ because certain expansion coefficients would be unbounded when $\lambda'' - \lambda' \rightarrow 0$, thus impeding the subsequent integration. In order to construct a useful approximation to (45) the idea is to rewrite it as a sum

$$D_0(\Delta, \lambda', \lambda'') = d_{\text{reg}} + d_{\text{irreg}}, \quad (\text{A } 1)$$

where d_{reg} contains the terms with bounded Δ expansion coefficients i.e.

$$d_{\text{reg}} = 2(1 - \cos \Delta) R_L(0) - \frac{27}{55} \Gamma\left(\frac{1}{3}\right) \alpha \varepsilon^{\frac{2}{3}} |\lambda'' - \lambda'|^{\frac{2}{3}}. \quad (\text{A } 2)$$

The remaining terms in (45) are irregular since they contain $r^2(\lambda', \lambda'')$ in fractional powers. We find

$$d_{\text{irreg}} = \frac{F}{G}, \quad (\text{A } 3)$$

where

$$F = \frac{9}{110} \Gamma\left(\frac{1}{3}\right) \alpha \varepsilon^{\frac{2}{3}} \{6(\lambda'^2 + \lambda''^2) \cos \Delta - \lambda' \lambda'' (5 + 7 \cos(2\Delta))\} \quad (\text{A } 4)$$

and

$$G = \left\{ (\lambda'' - \lambda')^2 + 4\lambda' \lambda'' \sin^2\left(\frac{\Delta}{2}\right) \right\}^{\frac{2}{3}} = (\lambda'^2 + \lambda''^2 - 2\lambda' \lambda'' \cos \Delta)^{\frac{2}{3}}. \quad (\text{A } 5)$$

By expanding d_{reg} and F to the second order in Δ and replacing G with the approximation

$$G_{\text{approx}} = \{(\lambda'' - \lambda')^2 + \lambda' \lambda'' \Delta^2\}^{\frac{2}{3}}. \quad (\text{A } 6)$$

we may construct the approximation

$$D_0(\Delta, \lambda', \lambda'') = R_L(0) \Delta^2 + \frac{27}{55} \Gamma\left(\frac{1}{3}\right) \alpha \varepsilon^{2/3} \times \left\{ \left[(\lambda'' - \lambda')^2 + \lambda' \lambda'' \Delta^2 \right]^{1/3} - |\lambda'' - \lambda'|^{2/3} + \frac{1}{3} \frac{\left[\lambda' \lambda'' - \frac{3}{2} (\lambda'' - \lambda')^2 \right] \Delta^2}{\left[(\lambda'' - \lambda')^2 + \lambda' \lambda'' \Delta^2 \right]^{2/3}} \right\}, \quad (\text{A } 7)$$

from which (89) follows immediately. Numerical experiments and theoretical analysis show that the impact of the error committed in the approximation (A 6) on the double integral (27) is $\mathcal{O}(\Delta^{\frac{11}{3}})$. The mathematical and computational merits of (45) and (A 7)

are equivalent for small Δ and $\lambda' \neq \lambda''$; they agree up to but not including the 4th order in Δ . Moreover they both satisfy the relation

$$\lim_{\Delta \rightarrow 0} D_0(\Delta, \lambda', \lambda'') = 0, \quad (\text{A } 8)$$

and both give the correct point limit $D_0(\Delta, R, R)$ in the ‘‘diagonal case’’ $\lambda' = \lambda'' = R$, cf. (48).

Next we shall give an asymptotic analysis of $D(\mu, \Delta)$, or rather $D^*(\mu, \Delta)$, which is valid in the limit $\Delta \rightarrow 0$. The analysis becomes simpler when we retain the exact denominator (A 5). If we take (45)), subtract the $R_L(0)$ term, and divide by $\alpha \varepsilon^{\frac{2}{3}}$, the resulting expression can be written

$$D_0^*(\Delta, \xi, \eta) = -\frac{9}{110} \Gamma\left(\frac{1}{3}\right) \left\{ 6|\xi - \eta|^{\frac{2}{3}} - \frac{6(\xi - \eta)^2 + (14\xi\eta - 3\xi^2 - 3\eta^2)\Delta^2}{(\xi^2 + \eta^2 - 2\xi\eta \cos \Delta)^{\frac{2}{3}}} \right\}. \quad (\text{A } 9)$$

The corresponding double integral is

$$D^*(\mu, \Delta) = \int_{-\infty}^{\infty} \int_{-\infty}^{\infty} h^*(\mu, \xi) h^*(\mu, \eta) D_0^*(\Delta, \xi, \eta) d\xi d\eta, \quad (\text{A } 10)$$

where h^* is the scaled and normalized filtering function defined in (47). We shall derive the following asymptotic expansion applying to $D^*(\mu, \Delta)$ for small Δ ,

$$D^*(\mu, \Delta) \sim c_{5/3}(\mu) \Delta^{\frac{5}{3}} + c_2(\mu) \Delta^2 + c_{11/3}(\mu) \Delta^{\frac{11}{3}} + c_4(\mu) \Delta^4 + \dots, \quad (\text{A } 11)$$

and we shall find formulas for $c_{5/3}(\mu)$ and $c_2(\mu)$. To accomplish this task we shall work in the complex domain \mathbb{C} and split the components of (A 9)–(A 10) and h^* as far as possible in ‘‘atoms’’, in a way that we shall now describe. The complex decomposition of h^* in partial fractions is

$$h^*(\mu, z) = \frac{1}{\pi \mu} \frac{1}{(z - c)(z - \bar{c})} = \frac{1}{2\pi i} \left(\frac{1}{z - c} - \frac{1}{z - \bar{c}} \right), \quad (\text{A } 12)$$

where

$$c = 1 + \frac{i}{\mu}, \quad \mu > 0. \quad (\text{A } 13)$$

An important building block for performing the first integration in (A 10) is the integral

$$I = \int_{-\infty}^{+\infty} \frac{\phi(z)}{z - c} dz, \quad (\text{A } 14)$$

where

$$\phi(z) = (z^2 + \eta^2 - 2z\eta \cos \Delta)^{\nu-1}. \quad (\text{A } 15)$$

We want to use (A 14) with $c = 1 \pm i/\mu$ but first it will be taken as a general complex constant satisfying $\Im(c) \neq 0$. We assume $\eta \in \mathbb{R}$ and consider general real values of ν

although we are particularly interested in $\nu = \frac{1}{3}$. We make a complex factorization of the quadratic polynomial in (A 15):

$$z^2 + \eta^2 - 2z\eta \cos \Delta = (z - a)(z - b), \quad (\text{A } 16)$$

where

$$(a, b) = \eta(e^{i\Delta}, e^{-i\Delta}). \quad (\text{A } 17)$$

By deflecting the contour in (A 14) we can write

$$I = I_m + I_p, \quad (\text{A } 18)$$

where

$$I_m = \int_{-\infty}^a \frac{\phi(z)}{z - c} dz \quad (\text{A } 19)$$

and

$$I_p = \int_a^{+\infty} \frac{\phi(z)}{z - c} dz. \quad (\text{A } 20)$$

Beginning with (A 20) we have

$$I_p = \int_a^{+\infty} \frac{(z - a)^{\nu-1} (z - b)^{\nu-1}}{z - c} dz. \quad (\text{A } 21)$$

We make the substitution $z = c - (c - a)/u$ and obtain

$$I_p = (a - c)^{2\nu-2} \int_0^1 u^{1-2\nu} (1 - u)^{\nu-1} \left(1 - u \frac{c - b}{c - a}\right)^{\nu-1} du, \quad (\text{A } 22)$$

which is a hypergeometric integral. Indeed it can be shown that

$$I_p = \frac{\Gamma(2 - 2\nu)\Gamma(\nu)}{\Gamma(2 - \nu)} (a - c)^{2\nu-2} F\left(1 - \nu, 2 - 2\nu; 2 - \nu; \frac{c - b}{c - a}\right), \quad (\text{A } 23)$$

where $F = {}_2F_1$ is the usual Gaussian hypergeometric function. Applying the $z \mapsto 1 - z$ transform (A 23) becomes after reduction,

$$I_p = \pi \csc(2\pi\nu) \left(\frac{\Gamma(\nu)}{\Gamma(1 - \nu)\Gamma(2\nu)} \frac{(a - b)^{2\nu-1}}{a - c} F\left(1, \nu; 2\nu; \frac{a - b}{a - c}\right) - (a - c)^{\nu-1} (b - c)^{\nu-1} \right). \quad (\text{A } 24)$$

Next we consider I_m given by (A 19). We have

$$I_m = \int_{-\infty}^a \frac{(z - a)^{\nu-1} (z - b)^{\nu-1}}{z - c} dz. \quad (\text{A } 25)$$

By substituting $z = -u$ and making the branch interpretation $(-1)^{2\nu} = 1$ we get

$$I_m = - \int_{-a}^{+\infty} \frac{(u+a)^{\nu-1}(u+b)^{\nu-1}}{u+c} du. \quad (\text{A } 26)$$

Thus, if we write $I_m = I_m(\nu, a, b, c)$ and $I_p = I_p(\nu, a, b, c)$ we have obtained the formula

$$I_m(\nu, a, b, c) = -I_p(\nu, -a, -b, -c). \quad (\text{A } 27)$$

From (A 18), (A 24), (A 27) we deduce that

$$\begin{aligned} I = I(\nu, a, b, c) &= \frac{\pi \csc(2\pi\nu)}{(a-b)(a-c)(b-c)\Gamma(1-\nu)} \\ &\times \left(-(a-b)[(a-c)^\nu(b-c)^\nu - (c-a)^\nu(c-b)^\nu] \Gamma(1-\nu) \right. \\ &\left. + [(a-b)^{2\nu} - (b-a)^{2\nu}](b-c) \frac{\Gamma(\nu)}{\Gamma(2\nu)} F\left(1, \nu; 2\nu; \frac{a-b}{a-c}\right) \right). \end{aligned} \quad (\text{A } 28)$$

We shall also need the integral

$$I_1 = \int_{-\infty}^{+\infty} z \frac{\phi(z)}{z-c} dz. \quad (\text{A } 29)$$

By writing $z = c + (z-c)$ we see that this becomes

$$I_1 = cI + I_0, \quad (\text{A } 30)$$

where I was given in (A 28) and

$$I_0 = \int_{-\infty}^{+\infty} \phi(z) dz. \quad (\text{A } 31)$$

Clearly we have

$$I_0 = - \lim_{c \rightarrow \infty} (cI(\nu, a, b, c)) \quad \left(\nu < \frac{1}{2} \right), \quad (\text{A } 32)$$

which results in

$$I_0 = I_0(\nu, a, b) = \frac{2^{1-2\nu} \pi^{\frac{3}{2}} \csc(2\pi\nu) ((a-b)^{2\nu} - (b-a)^{2\nu})}{(a-b)\Gamma(1-\nu)\Gamma(\frac{1}{2} + \nu)}. \quad (\text{A } 33)$$

It can be shown that

$$I_0\left(\frac{1}{3}, \eta e^{i\Delta}, \eta e^{-i\Delta}\right) = \frac{1}{2} \sqrt{\frac{3}{\pi}} \Gamma\left(\frac{1}{3}\right) \Gamma\left(\frac{1}{6}\right) \sin^{-\frac{1}{3}} \Delta |\eta|^{-\frac{1}{3}}. \quad (\text{A } 34)$$

We shall here need the expansion formula

$$\sin^{-\frac{1}{3}} \Delta = \Delta^{-\frac{1}{3}} + \frac{1}{18} \Delta^{\frac{5}{3}} + \mathcal{O}(\Delta^{\frac{11}{3}}). \quad (\text{A } 35)$$

The next step is to expand the first-integral components I in (A 14) and I_1 in (A 29) in power series in Δ , where we take $\nu = \frac{1}{3}$ and (a, b) from (A 17). Beginning with I we multiply by $1/(2\pi i)$ and thus define

$$J(\Delta, c, \eta) = \frac{1}{2\pi i} I\left(\frac{1}{3}, \eta e^{i\Delta}, \eta e^{-i\Delta}, c\right) \quad (\text{A } 36)$$

cf. expression (A 28). We see from this that

$$J(\Delta, c, \eta) = \frac{A_1 + A_2 F}{A_3} \quad (\text{A } 37)$$

where

$$A_1 = \Gamma^2(2/3)(-1 + e^{2i\Delta})\eta \\ \times \{(c - e^{-i\Delta}\eta)^{\frac{1}{3}}(c - e^{i\Delta}\eta)^{\frac{1}{3}} - (-c + e^{-i\Delta}\eta)^{\frac{1}{3}}(-c + e^{i\Delta}\eta)^{\frac{1}{3}}\}, \quad (\text{A } 38)$$

$$A_2 = 2^{\frac{2}{3}}\sqrt{3}\Gamma\left(\frac{1}{3}\right)i(-ce^{i\Delta} + \eta)\sin^{\frac{2}{3}}\Delta\eta|\eta|^{-\frac{1}{3}}, \quad (\text{A } 39)$$

$$A_3 = 2\sqrt{3}\Gamma^2\left(\frac{2}{3}\right)\sin\Delta(ce^{i\Delta} - \eta)(-c + e^{i\Delta}\eta)\eta, \quad (\text{A } 40)$$

and

$$F = F\left(\frac{1}{3}, 1; \frac{2}{3}; \frac{2\eta\sin\Delta}{i(c - \eta\cos\Delta) + \eta\sin\Delta}\right). \quad (\text{A } 41)$$

Here we have used the identity

$$i^{\frac{2}{3}} - (-i)^{\frac{2}{3}} = i\sqrt{3}. \quad (\text{A } 42)$$

By expanding $J(\Delta, c, \eta)$ in powers of Δ up to the second order we obtain

$$J(\Delta, c, \eta) = a_{-1/3}\Delta^{-\frac{1}{3}} + a_0 + a_{5/3}\Delta^{\frac{5}{3}} + a_2\Delta^2 + \mathcal{O}(\Delta^{\frac{11}{3}}), \quad (\text{A } 43)$$

where

$$a_{-1/3} = -\frac{\Gamma(\frac{1}{6})i}{2\sqrt{\pi}\Gamma(\frac{2}{3})}\frac{|\eta|^{-\frac{1}{3}}}{\eta - c}, \quad (\text{A } 44)$$

$$a_0 = -\frac{i}{\sqrt{3}}\frac{(c - \eta)^{\frac{2}{3}} - (\eta - c)^{\frac{2}{3}}}{(\eta - c)^2} \quad (\text{A } 45)$$

$$a_{5/3} = \frac{\Gamma(\frac{1}{6})i}{180\sqrt{\pi}\Gamma(\frac{2}{3})}\frac{4\eta^2 + 55c\eta - 5c^2}{(\eta - c)^3}|\eta|^{-\frac{1}{3}}, \quad (\text{A } 46)$$

and

$$a_2 = \frac{2ic\eta}{3\sqrt{3}}\frac{(c - \eta)^{\frac{2}{3}} - (\eta - c)^{\frac{2}{3}}}{(\eta - c)^4}. \quad (\text{A } 47)$$

Similarly we have

$$J_1(\Delta, c, \eta) = \frac{1}{2\pi i} I_1\left(\frac{1}{3}, \eta e^{i\Delta}, \eta e^{-i\Delta}, c\right). \quad (\text{A } 48)$$

By using (A 30), (A 34)–(A 35), and (A 44)–(A 47) we get the expansion

$$J_1(\Delta, c, \eta) = b_{-1/3} \Delta^{-\frac{1}{3}} + b_0 + b_{5/3} \Delta^{\frac{5}{3}} + b_2 \Delta^2 + \mathcal{O}(\Delta^{\frac{11}{3}}), \quad (\text{A } 49)$$

where

$$b_{-1/3} = -\frac{\Gamma(\frac{1}{6}) i}{2\sqrt{\pi}\Gamma(\frac{2}{3})} \frac{\eta|\eta|^{-\frac{1}{3}}}{\eta - c}, \quad (\text{A } 50)$$

and

$$b_0 = -\frac{i c (c - \eta)^{\frac{2}{3}} - (\eta - c)^{\frac{2}{3}}}{\sqrt{3} (\eta - c)^2}, \quad (\text{A } 51)$$

$$b_{5/3} = -\frac{\Gamma(\frac{1}{6}) i (5\eta^2 - 19c\eta - 40c^2)}{180\sqrt{\pi}\Gamma(\frac{2}{3})} \frac{\eta|\eta|^{-\frac{1}{3}}}{(\eta - c)^3}, \quad (\text{A } 52)$$

and

$$b_2 = \frac{2 i c^2 \eta (c - \eta)^{\frac{2}{3}} - (\eta - c)^{\frac{2}{3}}}{3\sqrt{3} (\eta - c)^4}. \quad (\text{A } 53)$$

Proceeding to the second integration in (A 10) we shall use (A 44)–(A 47) and (A 50)–(A 53) to evaluate various expansion coefficients related to individual parts of the expression (A 9). We begin with the coefficient c_0^{yy} of Δ^0 in the filtered double integral of

$$u(\xi, \eta; \Delta) = \frac{\eta^2}{(\xi^2 + \eta^2 - 2\xi\eta \cos \Delta)^{\frac{2}{3}}}. \quad (\text{A } 54)$$

By (A 12) we have

$$c_0^{yy} = \frac{1}{\pi\mu} \int_{-\infty}^{+\infty} \{a_0(\eta) + \bar{a}_0(\eta)\} \frac{\eta^2}{(\eta - c)(\eta - \bar{c})} d\eta \quad (\text{A } 55)$$

with a_0 given in (A 45). We need the identity

$$(c - \eta)^{\frac{2}{3}} - (\eta - c)^{\frac{2}{3}} = \left(-\frac{3}{2} + \frac{\sqrt{3}}{2} i\right) (\eta - c)^{\frac{2}{3}}, \quad (\text{A } 56)$$

which is valid when $\eta \in \mathbb{R}$, $\Im(c) > 0$. This gives

$$a_0(\eta) = \frac{1}{2} (1 + i\sqrt{3})(\eta - c)^{-\frac{4}{3}}. \quad (\text{A } 57)$$

We shall evaluate the auxiliary integral

$$I(\alpha, n) = \int_{-\infty}^{+\infty} \eta^n \frac{(\eta - c)^\alpha}{\eta - \bar{c}} d\eta, \quad (\text{A } 58)$$

where $n \in \mathbb{N}$, $\alpha + n < 0$, and $\Im(c) > 0$ as in (A 13). The integration path from $-\infty$ to $+\infty$ is augmented with an infinite semicircle below the real axis going from $+\infty$ back to $-\infty$. In this way we avoid the irregular singularity c . The contour only encloses the simple pole $\eta = \bar{c}$. Hence by the Cauchy and Jordan theorems we obtain

$$I(\alpha, n) = -2\pi i (-2i)^\alpha \mu^{-n-\alpha} (\mu - i)^n. \quad (\text{A } 59)$$

We obtain by using (A 55), (A 57), (A 58):

$$c_0^{yy} = \frac{1}{\pi\mu} \left(\frac{1}{2} (1 + i\sqrt{3}) I\left(-\frac{7}{3}, 2\right) + \frac{1}{2} (1 - i\sqrt{3}) \bar{I}\left(-\frac{7}{3}, 2\right) \right). \quad (\text{A } 60)$$

By inserting (A 59) we get after reduction

$$c_0^{yy} = -2^{-\frac{1}{3}} \mu^{-\frac{2}{3}} (\mu^2 - 1). \quad (\text{A } 61)$$

By the same method we evaluate

$$c_2^{yy} = \frac{1}{\pi\mu} \int_{-\infty}^{+\infty} \{a_2(\eta) + \bar{a}_2(\eta)\} \frac{\eta^2}{(\eta - c)(\eta - \bar{c})} d\eta \quad (\text{A } 62)$$

with a_2 given in (A 47). By (A 56) this can be written

$$a_2(\eta) = -\frac{1}{3} (1 + i\sqrt{3}) c \eta (\eta - c)^{-\frac{10}{3}}. \quad (\text{A } 63)$$

Then

$$c_2^{yy} = \frac{1}{\pi\mu} \left(-\frac{1}{3} (1 + i\sqrt{3}) c I\left(-\frac{13}{3}, 3\right) - \frac{1}{3} (1 - i\sqrt{3}) \bar{c} \bar{I}\left(-\frac{13}{3}, 3\right) \right), \quad (\text{A } 64)$$

which reduces to

$$c_2^{yy} = -\frac{1}{2} 2^{-\frac{1}{3}} \mu^{-\frac{2}{3}} (\mu^4 - 1). \quad (\text{A } 65)$$

Now we replace the model function (A 54) with

$$u(\xi, \eta; \Delta) = \frac{\xi \eta}{(\xi^2 + \eta^2 - 2\xi\eta \cos \Delta)^{\frac{2}{3}}}. \quad (\text{A } 66)$$

In analogy with (A 55) we want to determine

$$c_0^{xy} = \frac{1}{\pi\mu} \int_{-\infty}^{+\infty} \{b_0(\eta) + \bar{b}_0(\eta)\} \frac{\eta}{(\eta - c)(\eta - \bar{c})} d\eta \quad (\text{A } 67)$$

with b_0 given by (A 51). By (A 56) this can be written

$$b_0(\eta) = \frac{1}{2} (1 + i\sqrt{3}) c (\eta - c)^{-\frac{4}{3}}. \quad (\text{A } 68)$$

Then

$$c_0^{xy} = \frac{1}{\pi\mu} \left(\frac{1}{2} (1 + i\sqrt{3}) c I\left(-\frac{7}{3}, 1\right) + \frac{1}{2} (1 - i\sqrt{3}) \bar{c} \bar{I}\left(-\frac{7}{3}, 1\right) \right), \quad (\text{A } 69)$$

which reduces to

$$c_0^{xy} = -2^{-\frac{1}{3}}\mu^{-\frac{2}{3}}(\mu^2 + 1). \quad (\text{A } 70)$$

Proceeding to the coefficient c_2^{xy} of Δ^2 we get similarly:

$$c_2^{xy} = \frac{1}{\pi\mu} \int_{-\infty}^{+\infty} \{b_2(\eta) + \bar{b}_2(\eta)\} \frac{\eta}{(\eta - c)(\eta - \bar{c})} d\eta \quad (\text{A } 71)$$

with

$$b_2(\eta) = -\frac{1}{3}(1 + i\sqrt{3})c^2\eta(\eta - c)^{-\frac{10}{3}}. \quad (\text{A } 72)$$

We get

$$c_2^{xy} = \frac{1}{\pi\mu} \left(-\frac{1}{3}(1 + i\sqrt{3})c^2 I\left(-\frac{13}{3}, 2\right) - \frac{1}{3}(1 - i\sqrt{3})\bar{c}^2 \bar{I}\left(-\frac{13}{3}, 2\right) \right) \quad (\text{A } 73)$$

which reduces to

$$c_2^{xy} = -\frac{1}{6}2^{-\frac{1}{3}}\mu^{-\frac{2}{3}}(\mu^2 + 1)^2. \quad (\text{A } 74)$$

In completion we note that we of course have the identities

$$c_0^{xx} = c_0^{yy}, \quad c_2^{xx} = c_2^{yy}. \quad (\text{A } 75)$$

Now we determine the coefficients associated with the fractional powers of Δ and begin with some auxiliary integrals. We have

$$I_n(\alpha, c) = \int_0^{+\infty} \frac{t^{\alpha-1}}{(t-c)^n} dt = \frac{\Gamma(n-\alpha)}{\Gamma(1-\alpha)(n-1)!} (-c)^{\alpha-n} \pi \csc(\pi\alpha) \quad (\text{A } 76)$$

$(n \in \mathbb{N}, 0 < \alpha < n, c \notin \mathbb{R}).$

From this we can derive the integral

$$\phi_n(\alpha, c) = \int_{-\infty}^{+\infty} \frac{|t|^{\alpha-1}}{(t-c)^n} dt \quad (\text{A } 77)$$

by treating the intervals $(-\infty, 0)$ and $(0, \infty)$ separately. We find

$$\phi_n(\alpha, c) = \frac{(-1)^n \Gamma(n-\alpha)}{\Gamma(1-\alpha)(n-1)! c^n} ((-c)^\alpha + c^\alpha) \pi \csc(\pi\alpha) \quad (\text{A } 78)$$

$(n \in \mathbb{N}, 0 < \alpha < n, c \notin \mathbb{R}).$

Moreover we need the integrals

$$\psi_n(\alpha, c, d) = \int_{-\infty}^{+\infty} \frac{|t|^{\alpha-1}}{(t-c)^n (t-d)} dt \quad (\text{A } 79)$$

$(n \in \mathbb{N}, 0 < \alpha < n+1, c \notin \mathbb{R}, d \notin \mathbb{R}, c \neq d)$

for $n = 1, 2, 3$. We have

$$\psi_1(\alpha, c, d) = \frac{\pi \csc(\pi\alpha)}{cd(c-d)} (c((-d)^\alpha + d^\alpha) - d((-c)^\alpha + c^\alpha)) \quad (\text{A } 80)$$

$$\begin{aligned} \psi_2(\alpha, c, d) &= -\frac{\pi \csc(\pi\alpha)}{c^2 d(c-d)^2} \\ &\times \left\{ c^2((-d)^\alpha + d^\alpha) + (-c)^\alpha cd(\alpha-2) + c^{\alpha+1} d(\alpha-2) \right. \\ &\quad \left. - (-c)^\alpha d^2(\alpha-1) - c^\alpha d^2(\alpha-1) \right\} \end{aligned} \quad (\text{A } 81)$$

$$\begin{aligned} \psi_3(\alpha, c, d) &= \frac{\pi \csc(\pi\alpha)}{2c^3 d(c-d)^3} \left\{ 2c^3((-d)^\alpha + d^\alpha) \right. \\ &\quad + (-c)^{\alpha+1} cd(\alpha-3)(\alpha-2) - c^{\alpha+2} d(\alpha-3)(\alpha-2) \\ &\quad + 2(-c)^\alpha cd^2(\alpha-3)(\alpha-1) + 2c^{\alpha+1} d^2(\alpha-3)(\alpha-1) \\ &\quad \left. - (-c)^\alpha d^3(\alpha-2)(\alpha-1) - c^\alpha d^3(\alpha-2)(\alpha-1) \right\}. \end{aligned} \quad (\text{A } 82)$$

Our first goal is to compute the coefficient $c_{-1/3}^{yy}$ for $\Delta^{-\frac{1}{3}}$ in the filtered double integral of (A 54). Indeed we have from (A 12)–(A 13):

$$c_{-1/3}^{yy} = \frac{1}{2\pi i} \int_{-\infty}^{+\infty} \{a_{-1/3}(\eta) + \bar{a}_{-1/3}(\eta)\} \eta^2 \left(\frac{1}{\eta-c} - \frac{1}{\eta-\bar{c}} \right) d\eta \quad (\text{A } 83)$$

where $a_{-1/3}(\eta)$ was given in (A 44). We express $c_{-1/3}^{yy}$ in terms of the functions ϕ_2 and ψ_1 ,

$$\begin{aligned} c_{-1/3}^{yy} &= -\frac{\Gamma(\frac{1}{6}) i}{2\sqrt{\pi}\Gamma(\frac{2}{3})} \frac{1}{2\pi i} \\ &\times \left\{ \phi_2\left(\frac{8}{3}, c\right) - \psi_1\left(\frac{8}{3}, c, \bar{c}\right) - \psi_1\left(\frac{8}{3}, \bar{c}, c\right) + \phi_2\left(\frac{8}{3}, \bar{c}\right) \right\}, \end{aligned} \quad (\text{A } 84)$$

which evaluates to

$$\begin{aligned} c_{-1/3}^{yy} &= \frac{\Gamma(1/6)}{6\sqrt{3}\pi\Gamma(2/3)\mu^{2/3}} \\ &\times \left\{ 3i\mu((-i-\mu)^{\frac{2}{3}} - (i-\mu)^{\frac{2}{3}} - (-i+\mu)^{\frac{2}{3}} + (i+\mu)^{\frac{2}{3}}) \right. \\ &\quad \left. + 2((-i-\mu)^{\frac{2}{3}} + (i-\mu)^{\frac{2}{3}} + (-i+\mu)^{\frac{2}{3}} + (i+\mu)^{\frac{2}{3}}) \right\}. \end{aligned} \quad (\text{A } 85)$$

By defining

$$v = \frac{2}{3} \operatorname{arccot} \mu \quad (\text{A } 86)$$

we can reduce (A 85) to

$$c_{-1/3}^{yy} = \frac{(1 + \mu^2)^{\frac{1}{3}} \Gamma(\frac{1}{6})}{6\sqrt{3}\pi \Gamma(\frac{2}{3}) \mu^{\frac{2}{3}}} ((2 + 3\sqrt{3}\mu) \cos v + (2\sqrt{3} - 3\mu) \sin v) \quad (\text{A } 87)$$

Next we evaluate the corresponding coefficient $c_{5/3}^{yy}$ of $\Delta^{\frac{5}{3}}$, i.e.

$$c_{5/3}^{yy} = \frac{1}{2\pi i} \int_{-\infty}^{+\infty} \{a_{5/3}(\eta) + \bar{a}_{5/3}(\eta)\} \eta^2 \left(\frac{1}{\eta - c} - \frac{1}{\eta - \bar{c}} \right) d\eta \quad (\text{A } 88)$$

Here $a_{5/3}(\eta)$ was given by (A 46) and can be reformulated as

$$a_{5/3}(\eta) = \frac{\Gamma(\frac{1}{6}) i}{180\sqrt{\pi} \Gamma(\frac{2}{3})} \left(\frac{4}{\eta - c} + \frac{63c}{(\eta - c)^2} + \frac{54c^2}{(\eta - c)^3} \right) |\eta|^{-\frac{1}{3}} \quad (\text{A } 89)$$

Let us write

$$a_{5/3}(\eta) + \bar{a}_{5/3}(\eta) = p_1 + p_2 + p_3 \quad (\text{A } 90)$$

where

$$p_1 = 4k |\eta|^{-\frac{1}{3}} \left(\frac{1}{\eta - c} - \frac{1}{\eta - \bar{c}} \right) \quad (\text{A } 91)$$

$$p_2 = 63k |\eta|^{-\frac{1}{3}} \left(\frac{c}{(\eta - c)^2} - \frac{\bar{c}}{(\eta - \bar{c})^2} \right) \quad (\text{A } 92)$$

$$p_3 = 54k |\eta|^{-\frac{1}{3}} \left(\frac{c^2}{(\eta - c)^3} - \frac{\bar{c}^2}{(\eta - \bar{c})^3} \right) \quad (\text{A } 93)$$

$$k = \frac{\Gamma(\frac{1}{6}) i}{180\sqrt{\pi} \Gamma(\frac{2}{3})} \quad (\text{A } 94)$$

Then

$$c_{5/3}^{yy} = \frac{k}{2\pi i} (P_1 + P_2 + P_3) \quad (\text{A } 95)$$

where

$$P_1 = 4 \left(\phi_2 \left(\frac{8}{3}, c \right) - \psi_1 \left(\frac{8}{3}, c, \bar{c} \right) - \psi_1 \left(\frac{8}{3}, \bar{c}, c \right) + \phi_2 \left(\frac{8}{3}, \bar{c} \right) \right) \quad (\text{A } 96)$$

$$P_2 = 63 \left(c \phi_3 \left(\frac{8}{3}, c \right) - c \psi_2 \left(\frac{8}{3}, c, \bar{c} \right) - \bar{c} \psi_2 \left(\frac{8}{3}, \bar{c}, c \right) + \bar{c} \phi_3 \left(\frac{8}{3}, \bar{c} \right) \right) \quad (\text{A } 97)$$

$$P_3 = 54 \left(c^2 \phi_4 \left(\frac{8}{3}, c \right) - c^2 \psi_3 \left(\frac{8}{3}, c, \bar{c} \right) - \bar{c}^2 \psi_3 \left(\frac{8}{3}, \bar{c}, c \right) + \bar{c}^2 \phi_4 \left(\frac{8}{3}, \bar{c} \right) \right) \quad (\text{A } 98)$$

We can reformulate this in the same way as we did for $c_{-1/3}^{yy}$. The result is

$$c_{5/3}^{yy} = \frac{(1 + \mu^2)^{1/3} \Gamma(1/6) \Gamma(1/3)}{2160 \pi^{3/2} \mu^{2/3}} \times \left((-44 - 51\sqrt{3}\mu + 54\mu^2 + 81\sqrt{3}\mu^3) \cos v \right. \\ \left. + (-44\sqrt{3} + 51\mu + 54\sqrt{3}\mu^2 - 81\mu^3) \sin v \right). \quad (\text{A } 99)$$

Now we replace the model function with (A 66) in order to determine the coefficients $c_{-1/3}^{xy}$ for $\Delta^{-\frac{1}{3}}$ and $c_{5/3}^{xy}$ for $\Delta^{\frac{5}{3}}$. By making $\Delta \rightarrow \infty$ in (A 9) we infer that

$$c_{-1/3}^{xy} = c_{-1/3}^{yy}. \quad (\text{A } 100)$$

The coefficient $c_{5/3}^{xy}$ is given by

$$c_{5/3}^{xy} = \frac{1}{2\pi i} \int_{-\infty}^{+\infty} \{b_{5/3}(\eta) + \bar{b}_{5/3}(\eta)\} \eta \left(\frac{1}{\eta - c} - \frac{1}{\eta - \bar{c}} \right) d\eta \quad (\text{A } 101)$$

with $b_{5/3}(\eta)$ as given in (A 52). The evaluation of (A 101) follows the same pattern as for $c_{5/3}^{yy}$ and the result becomes

$$c_{5/3}^{xy} = \frac{(1 + \mu^2)^{\frac{1}{3}} \Gamma(1/6) \Gamma(1/3)}{2160 \pi^{\frac{3}{2}} \mu^{\frac{2}{3}}} \times \left\{ (64 + 111\sqrt{3}\mu + 54\mu^2 + 81\sqrt{3}\mu^3) \cos v \right. \\ \left. + (64\sqrt{3} - 111\mu + 54\sqrt{3}\mu^2 - 81\mu^3) \sin v \right\}. \quad (\text{A } 102)$$

Finally, we have of course the identities

$$c_{-1/3}^{xx} = c_{-1/3}^{yy}, \quad c_{5/3}^{xx} = c_{5/3}^{yy}. \quad (\text{A } 103)$$

We are now ready to assemble all the necessary pieces in order to determine the coefficients $a(\mu) = c_{5/3}(\mu)$ and $b(\mu) = c_2(\mu)$ in the asymptotic expansion (A 11). Conferring with (A 9) we obtain

$$a(\mu) = \frac{9}{110} \Gamma\left(\frac{1}{3}\right) \times (6c_{5/3}^{xx} - 12c_{5/3}^{xy} + 6c_{5/3}^{yy} + 14c_{-1/3}^{xy} - 3c_{-1/3}^{xx} - 3c_{-1/3}^{yy}) \quad (\text{A } 104)$$

and

$$b(\mu) = \frac{9}{110} \Gamma\left(\frac{1}{3}\right) (6c_2^{xx} - 12c_2^{xy} + 6c_2^{yy} + 14c_0^{xy} - 3c_0^{xx} - 3c_0^{yy}), \quad (\text{A } 105)$$

which evaluate to (52)–(54). The final asymptotic formula is then

$$D^*(\mu, \Delta) \sim a(\mu)\Delta^{\frac{5}{3}} + b(\mu)\Delta^2. \quad (\text{A } 106)$$

The relative error of this expression tends to zero as $\Delta \rightarrow 0$. However, the convergence is not uniform with respect to $\mu \in (0, \infty)$ since we have

$$|a(\mu)| \rightarrow \infty \text{ as } \mu \rightarrow 0, \quad |b(\mu)| \rightarrow \infty \text{ as } \mu \rightarrow 0, \quad (\text{A } 107)$$

and

$$|a(\mu)| \rightarrow \infty \text{ as } \mu \rightarrow \infty, \quad |b(\mu)| \rightarrow \infty \text{ as } \mu \rightarrow \infty. \quad (\text{A } 108)$$

The best precision of (A 106) is obtained when $\mu \approx 1$. By a heuristic argument it can be shown that (A 106) with the coefficients (52)–(54) also holds good for the model (89) where we have used the approximation $\sin(\Delta/2) \approx \Delta/2$.

B Wave-Number Formulation, Details

We see from (31)–(33) that there are three different vector arguments $\boldsymbol{\rho}$ which are listed here for convenience

$$\boldsymbol{\rho} = \begin{cases} (\lambda'' - \lambda') \mathbf{b}^- & = (\lambda'' - \lambda') (\mathbf{i}_1 \cos(\Delta/2) - \mathbf{i}_2 \sin(\Delta/2)). \\ (\lambda'' - \lambda') \mathbf{b}^+ & = (\lambda'' - \lambda') (\mathbf{i}_1 \cos(\Delta/2) + \mathbf{i}_2 \sin(\Delta/2)). \\ \lambda'' \mathbf{b}^+ - \lambda' \mathbf{b}^- & = (\lambda'' - \lambda') \mathbf{i}_1 \cos(\Delta/2) + (\lambda' + \lambda'') \mathbf{i}_2 \sin(\Delta/2). \end{cases} \quad (\text{B } 1)$$

The evaluation of (23)–(25) requires the determination of

$$\int_{-\infty}^{\infty} h(\mu, \lambda') d\lambda' \int_{-\infty}^{\infty} h(\mu, \lambda'') d\lambda'' e^{i\mathbf{k} \cdot \boldsymbol{\rho}}, \quad (\text{B } 2)$$

with $h(\mu, \lambda)$ given by (11), in all three cases (B 1). We use the relation for real x

$$\int_{-\infty}^{\infty} h(\mu, \lambda) e^{ix\lambda} d\lambda = e^{ixR} \exp\left(-\frac{R}{\mu}|x|\right). \quad (\text{B } 3)$$

Inserting each of the three types of $\boldsymbol{\rho}$ (B 1) into (B 2) we get

$$\begin{aligned} & \int_{-\infty}^{\infty} h(\mu, \lambda') d\lambda' \int_{-\infty}^{\infty} h(\mu, \lambda'') d\lambda'' \exp(i(\lambda'' - \lambda') \mathbf{k} \cdot \mathbf{b}^-) = \\ & \int_{-\infty}^{\infty} h(\mu, \lambda') d\lambda' \int_{-\infty}^{\infty} h(\mu, \lambda'') d\lambda'' \exp(i(\lambda'' - \lambda') [k_1 \cos(\Delta/2) - k_2 \sin(\Delta/2)]) = \end{aligned}$$

$$\left| \int_{-\infty}^{\infty} h(\mu, \lambda) d\lambda \exp(i \lambda [k_1 \cos(\Delta/2) - k_2 \sin(\Delta/2)]) \right|^2 =$$

$$\exp(-\ell |k_1 \cos(\Delta/2) - k_2 \sin(\Delta/2)|), \quad (\text{B } 4)$$

$$\int_{-\infty}^{\infty} h(\mu, \lambda') d\lambda' \int_{-\infty}^{\infty} h(\mu, \lambda'') d\lambda'' \exp(i (\lambda'' - \lambda') \mathbf{k} \cdot \mathbf{b}^+) =$$

$$\int_{-\infty}^{\infty} h(\mu, \lambda') d\lambda' \int_{-\infty}^{\infty} h(\mu, \lambda'') d\lambda'' \exp(i (\lambda'' - \lambda') [k_1 \cos(\Delta/2) + k_2 \sin(\Delta/2)]) =$$

$$\left| \int_{-\infty}^{\infty} h(\mu, \lambda) d\lambda \exp(i \lambda [k_1 \cos(\Delta/2) + k_2 \sin(\Delta/2)]) \right|^2 =$$

$$\exp(-\ell |k_1 \cos(\Delta/2) + k_2 \sin(\Delta/2)|), \quad (\text{B } 5)$$

and

$$\int_{-\infty}^{\infty} h(\mu, \lambda') d\lambda' \int_{-\infty}^{\infty} h(\mu, \lambda'') d\lambda'' \exp(i [\lambda'' \mathbf{k} \cdot \mathbf{b}^+ - \lambda' \mathbf{k} \cdot \mathbf{b}^-]) =$$

$$\int_{-\infty}^{\infty} h(\mu, \lambda') d\lambda' \int_{-\infty}^{\infty} h(\mu, \lambda'') d\lambda'' \exp(i [(\lambda'' - \lambda') k_1 \cos(\Delta/2) + (\lambda' + \lambda'') k_2 \sin(\Delta/2)])$$

$$= \int_{-\infty}^{\infty} h(\mu, \lambda') d\lambda' \exp(-i \lambda' [k_1 \cos(\Delta/2) - k_2 \sin(\Delta/2)])$$

$$\times \int_{-\infty}^{\infty} h(\mu, \lambda'') d\lambda'' \exp(i \lambda'' [k_1 \cos(\Delta/2) + k_2 \sin(\Delta/2)]) =$$

$$\exp(2i R k_2 \sin(\Delta/2))$$

$$\times \exp\left(-\frac{\ell}{2} [|k_1 \cos(\Delta/2) - k_2 \sin(\Delta/2)| + |k_1 \cos(\Delta/2) + k_2 \sin(\Delta/2)|]\right), \quad (\text{B } 6)$$

where the filter length-scale is given by (12).

To determine D as given by (22) we must, according to (23)–(25) and (31)–(33), evaluate eight integrals:

$$I_{11}^- = \int_{-\infty}^{\infty} h(\mu, \lambda') d\lambda' \int_{-\infty}^{\infty} h(\mu, \lambda'') d\lambda'' R_{11}((\lambda'' - \lambda')\mathbf{b}^-), \quad (\text{B } 7)$$

$$I_{22}^- = \int_{-\infty}^{\infty} h(\mu, \lambda') d\lambda' \int_{-\infty}^{\infty} h(\mu, \lambda'') d\lambda'' R_{22}((\lambda'' - \lambda')\mathbf{b}^-), \quad (\text{B } 8)$$

$$I_{12}^- = \int_{-\infty}^{\infty} h(\mu, \lambda') d\lambda' \int_{-\infty}^{\infty} h(\mu, \lambda'') d\lambda'' R_{12}((\lambda'' - \lambda')\mathbf{b}^-), \quad (\text{B } 9)$$

$$I_{11}^+ = \int_{-\infty}^{\infty} h(\mu, \lambda') d\lambda' \int_{-\infty}^{\infty} h(\mu, \lambda'') d\lambda'' R_{11}((\lambda'' - \lambda')\mathbf{b}^+), \quad (\text{B } 10)$$

$$I_{22}^+ = \int_{-\infty}^{\infty} h(\mu, \lambda') d\lambda' \int_{-\infty}^{\infty} h(\mu, \lambda'') d\lambda'' R_{22}((\lambda'' - \lambda')\mathbf{b}^+), \quad (\text{B } 11)$$

$$I_{12}^+ = \int_{-\infty}^{\infty} h(\mu, \lambda') d\lambda' \int_{-\infty}^{\infty} h(\mu, \lambda'') d\lambda'' R_{12}((\lambda'' - \lambda')\mathbf{b}^+), \quad (\text{B } 12)$$

$$I_{11}^{+/-} = \int_{-\infty}^{\infty} h(\mu, \lambda') d\lambda' \int_{-\infty}^{\infty} h(\mu, \lambda'') d\lambda'' R_{11}(\lambda''\mathbf{b}^+ - \lambda'\mathbf{b}^-), \quad (\text{B } 13)$$

and

$$I_{22}^{+/-} = \int_{-\infty}^{\infty} h(\mu, \lambda') d\lambda' \int_{-\infty}^{\infty} h(\mu, \lambda'') d\lambda'' R_{22}(\lambda''\mathbf{b}^+ - \lambda'\mathbf{b}^-). \quad (\text{B } 14)$$

Using (B 4)–(B 6), we get

$$I_{11}^- = \frac{2}{55} B(1/2, 1/3) \frac{\alpha \varepsilon^{2/3}}{4\pi} \int_{-\infty}^{\infty} dk_1 \int_{-\infty}^{\infty} dk_2 \frac{3q^2 + 3k_1^2 + 11k_2^2}{(q^2 + k_1^2 + k_2^2)^{7/3}} \\ \times \exp(-\ell |k_1 \cos(\Delta/2) - k_2 \sin(\Delta/2)|), \quad (\text{B } 15)$$

$$I_{22}^- = \frac{2}{55} B(1/2, 1/3) \frac{\alpha \varepsilon^{2/3}}{4\pi} \int_{-\infty}^{\infty} dk_1 \int_{-\infty}^{\infty} dk_2 \frac{3q^2 + 11k_1^2 + 3k_2^2}{(q^2 + k_1^2 + k_2^2)^{7/3}} \\ \times \exp(-\ell |k_1 \cos(\Delta/2) - k_2 \sin(\Delta/2)|), \quad (\text{B } 16)$$

$$I_{12}^- = -\frac{16}{55} B(1/2, 1/3) \frac{\alpha \varepsilon^{2/3}}{4\pi} \int_{-\infty}^{\infty} dk_1 \int_{-\infty}^{\infty} dk_2 \frac{k_1 k_2}{(q^2 + k_1^2 + k_2^2)^{7/3}}$$

$$\times \exp(-\ell |k_1 \cos(\Delta/2) - k_2 \sin(\Delta/2)|), \quad (\text{B } 17)$$

$$I_{11}^+ = \frac{2}{55} B(1/2, 1/3) \frac{\alpha \varepsilon^{2/3}}{4\pi} \int_{-\infty}^{\infty} dk_1 \int_{-\infty}^{\infty} dk_2 \frac{3q^2 + 3k_1^2 + 11k_2^2}{(q^2 + k_1^2 + k_2^2)^{7/3}}$$

$$\times \exp(-\ell |k_1 \cos(\Delta/2) + k_2 \sin(\Delta/2)|), \quad (\text{B } 18)$$

$$I_{22}^+ = \frac{2}{55} B(1/2, 1/3) \frac{\alpha \varepsilon^{2/3}}{4\pi} \int_{-\infty}^{\infty} dk_1 \int_{-\infty}^{\infty} dk_2 \frac{3q^2 + 11k_1^2 + 3k_2^2}{(q^2 + k_1^2 + k_2^2)^{7/3}}$$

$$\times \exp(-\ell |k_1 \cos(\Delta/2) + k_2 \sin(\Delta/2)|), \quad (\text{B } 19)$$

$$I_{12}^+ = -\frac{16}{55} B(1/2, 1/3) \frac{\alpha \varepsilon^{2/3}}{4\pi} \int_{-\infty}^{\infty} dk_1 \int_{-\infty}^{\infty} dk_2 \frac{k_1 k_2}{(q^2 + k_1^2 + k_2^2)^{7/3}}$$

$$\times \exp(-\ell |k_1 \cos(\Delta/2) + k_2 \sin(\Delta/2)|), \quad (\text{B } 20)$$

$$I_{11}^{+/-} = \frac{2}{55} B(1/2, 1/3) \frac{\alpha \varepsilon^{2/3}}{4\pi} \int_{-\infty}^{\infty} dk_1 \int_{-\infty}^{\infty} dk_2 \frac{3q^2 + 3k_1^2 + 11k_2^2}{(q^2 + k_1^2 + k_2^2)^{7/3}} \exp(2i R k_2 \sin(\Delta/2))$$

$$\times \exp\left(-\frac{\ell}{2} [|k_1 \cos(\Delta/2) - k_2 \sin(\Delta/2)| + |k_1 \cos(\Delta/2) + k_2 \sin(\Delta/2)|]\right), \quad (\text{B } 21)$$

and

$$I_{22}^{+/-} = \frac{2}{55} B(1/2, 1/3) \frac{\alpha \varepsilon^{2/3}}{4\pi} \int_{-\infty}^{\infty} dk_1 \int_{-\infty}^{\infty} dk_2 \frac{3q^2 + 11k_1^2 + 3k_2^2}{(q^2 + k_1^2 + k_2^2)^{7/3}} \exp(2i R k_2 \sin(\Delta/2))$$

$$\times \exp\left(-\frac{\ell}{2} [|k_1 \cos(\Delta/2) - k_2 \sin(\Delta/2)| + |k_1 \cos(\Delta/2) + k_2 \sin(\Delta/2)|]\right). \quad (\text{B } 22)$$

We may now reformulate (23)–(25) in terms of double integrals over wave numbers. We get by (31)–(33) and (B 7)–(B 22)

$$\begin{aligned} \langle v^{-2} \rangle &= I_{11}^- \cos^2(\Delta/2) + I_{22}^- \sin^2(\Delta/2) - 2I_{12}^- \cos(\Delta/2) \sin(\Delta/2) = \\ &\frac{2}{55} B(1/2, 1/3) \frac{\alpha \varepsilon^{2/3}}{4\pi} \int_{-\infty}^{\infty} dk_1 \int_{-\infty}^{\infty} dk_2 \frac{3q^2 + 7(k_1^2 + k_2^2) + 4(k_2^2 - k_1^2) \cos \Delta + 8k_1 k_2 \sin \Delta}{(q^2 + k_1^2 + k_2^2)^{7/3}} \\ &\times \exp(-\ell |k_1 \cos(\Delta/2) - k_2 \sin(\Delta/2)|), \end{aligned} \quad (\text{B 23})$$

$$\begin{aligned} \langle v^{+2} \rangle &= I_{11}^+ \cos^2(\Delta/2) + I_{22}^+ \sin^2(\Delta/2) + 2I_{12}^+ \cos(\Delta/2) \sin(\Delta/2) = \\ &\frac{2}{55} B(1/2, 1/3) \frac{\alpha \varepsilon^{2/3}}{4\pi} \int_{-\infty}^{\infty} dk_1 \int_{-\infty}^{\infty} dk_2 \frac{3q^2 + 7(k_1^2 + k_2^2) + 4(k_2^2 - k_1^2) \cos \Delta - 8k_1 k_2 \sin \Delta}{(q^2 + k_1^2 + k_2^2)^{7/3}} \\ &\times \exp(-\ell |k_1 \cos(\Delta/2) + k_2 \sin(\Delta/2)|), \end{aligned} \quad (\text{B 24})$$

and

$$\begin{aligned} \langle v^- v^+ \rangle &= I_{11}^{+/-} \cos^2(\Delta/2) - I_{22}^{+/-} \sin^2(\Delta/2) = \frac{2}{55} B(1/2, 1/3) \frac{\alpha \varepsilon^{2/3}}{4\pi} \\ &\times \int_{-\infty}^{\infty} dk_1 \int_{-\infty}^{\infty} dk_2 \frac{(3q^2 + 7(k_1^2 + k_2^2)) \cos \Delta + 4(k_2^2 - k_1^2)}{(q^2 + k_1^2 + k_2^2)^{7/3}} \cos(\mu \ell k_2 \sin(\Delta/2)) \\ &\times \exp\left(-\frac{\ell}{2} [|k_1 \cos(\Delta/2) - k_2 \sin(\Delta/2)| + |k_1 \cos(\Delta/2) + k_2 \sin(\Delta/2)|]\right), \end{aligned} \quad (\text{B 25})$$

where we have used the relation $2R = \mu \ell$. The quantity D in (22) is determined by (B 23), (B 24), (B 25).

We may reformulate (B 23), (B 24), (B 25) by transforming the double integrals by using plane polar coordinate as integration variables. The transformation is

$$\begin{Bmatrix} k_1 \\ k_2 \end{Bmatrix} = \kappa \begin{Bmatrix} \cos \theta \\ \sin \theta \end{Bmatrix}. \quad (\text{B 26})$$

We get

$$\langle v^{-2} \rangle = \frac{2}{55} B(1/2, 1/3) \frac{\alpha \varepsilon^{2/3}}{4\pi} \int_0^{\infty} \frac{\kappa d\kappa}{(q^2 + \kappa^2)^{7/3}}$$

$$\times \int_0^{2\pi} (3q^2 + 7\kappa^2 - 4\kappa^2 \cos(\Delta + 2\theta)) \exp(-\ell\kappa |\cos(\theta + \Delta/2)|) d\theta \quad (\text{B } 27)$$

and

$$\langle v^{+2} \rangle = \frac{2}{55} B(1/2, 1/3) \frac{\alpha \varepsilon^{2/3}}{4\pi} \int_0^\infty \frac{\kappa d\kappa}{(q^2 + \kappa^2)^{7/3}} \\ \times \int_0^{2\pi} (3q^2 + 7\kappa^2 - 4\kappa^2 \cos(\Delta - 2\theta)) \exp(-\ell\kappa |\cos(\theta - \Delta/2)|) d\theta \quad (\text{B } 28)$$

or, in a simpler form,

$$\langle v^{-2} \rangle = \langle v^{+2} \rangle \equiv \langle v^2 \rangle = \alpha \varepsilon^{2/3} \frac{4}{55} B(1/2, 1/3) \int_0^\infty \frac{\kappa d\kappa}{(q^2 + \kappa^2)^{7/3}} \\ \times \frac{1}{2\pi} \int_0^{\pi/2} (3q^2 + 7\kappa^2 - 4\kappa^2 \cos(2\theta)) \exp(-\ell\kappa \cos\theta) d\theta, \quad (\text{B } 29)$$

and

$$\langle v^- v^+ \rangle = \alpha \varepsilon^{2/3} \frac{4}{55} B(1/2, 1/3) \int_0^\infty \frac{\kappa d\kappa}{(q^2 + \kappa^2)^{7/3}} \\ \times \frac{1}{2\pi} \int_0^{\pi/2} ((3q^2 + 7\kappa^2) \cos \Delta - 4\kappa^2 \cos(2\theta)) \cos(\mu \ell \kappa \sin \theta \sin(\Delta/2)) \\ \exp\left(-\frac{\ell\kappa}{2} \{|\cos(\theta + \Delta/2)| + |\cos(\theta - \Delta/2)|\}\right) d\theta. \quad (\text{B } 30)$$

Acknowledgements

This work has been conducted in connection with the establishment of the new Danish research infrastructure facility WindScanner.dk with support from the Danish Agency for Science-Technology and Innovation: Research Infrastructure 2009, Grant No. 2136-08-0022.

References

- Banakh, V. A., Smalikho, I. N., Köpp, F. & Werner, C. (1999), 'Measurements of turbulent energy dissipation rate with a cw doppler lidar in the atmospheric boundary layer', *J. Atmos. Ocean. Technol.* **16**, 1044–1061.
- Haugen, D. A., Kaimal, J. C. & Bradley, E. F. (1971), 'An experimental study of Reynolds stress and heat flux in the atmospheric surface layer', *Quart. J. Roy. Meteorol. Soc.* **97**, 168–180.
- Kristensen, L., Kirkegaard, P. & Mikkelsen, T. (2011), Determining the velocity fine structure by a laser anemometer with fixed orientation, Technical Report R-1762(EN), Risø DTU National Laboratory for Sustainable Energy.
- Kristensen, L., Lenschow, D. H., Kirkegaard, P. & Courtney, M. S. (1989), 'The spectral velocity tensor for homogeneous boundary-layer turbulence', *Boundary-Layer Meteorol.* **47**, 149–193.
- Smalikho, I. N. (1995), 'On measurement of the dissipation rate of the turbulent energy with a CW lidar', *Atmos. Oceanic Opt.* **8**, 788–793.
- von Kármán, T. (1948), 'Progress in the statistical theory of turbulence', *Proc. Nat. Acad. Sci.* **34**, 530–539.

DTU Vindenergi er et institut under Danmarks Tekniske Universitet med en unik integration af forskning, uddannelse, innovation og offentlige/private konsulentopgaver inden for vindenergi. Vores aktiviteter bidrager til nye muligheder og teknologier inden for udnyttelse af vindenergi, både globalt og nationalt. Forskningen har fokus på specifikke tekniske og videnskabelige områder, der er centrale for udvikling, innovation og brug af vindenergi, og som danner grundlaget for højt kvalificerede uddannelser på universitetet.

Vi har mere end 230 ansatte og heraf er ca. 60 ph.d. studerende. Forskningen tager udgangspunkt i 9 forskningsprogrammer, der er organiseret i tre hovedgrupper: vindenergisystemer, vindmølleteknologi og grundlag for vindenergi.

Danmarks Tekniske Universitet

DTU Vindenergi

Nils Koppels Allé

Bygning 403

2800 Kgs. Lyngby

Telefon 45 25 25 25

dtic@dtu.dk

www.vindenergi.dtu.dk

ISBN 978-87-92896-14-5