



## Linear discrete-time state space realization of a modified quadruple tank system with state estimation using Kalman filter

**Mohd. Azam, Sazuan Nazrah**

*Published in:*  
Journal of Physics: Conference Series

*Link to article, DOI:*  
[10.1088/1742-6596/783/1/012013](https://doi.org/10.1088/1742-6596/783/1/012013)

*Publication date:*  
2017

*Document Version*  
Publisher's PDF, also known as Version of record

[Link back to DTU Orbit](#)

*Citation (APA):*  
Mohd. Azam, S. N. (2017). Linear discrete-time state space realization of a modified quadruple tank system with state estimation using Kalman filter. *Journal of Physics: Conference Series*, 783, Article 012013 .  
<https://doi.org/10.1088/1742-6596/783/1/012013>

---

### General rights

Copyright and moral rights for the publications made accessible in the public portal are retained by the authors and/or other copyright owners and it is a condition of accessing publications that users recognise and abide by the legal requirements associated with these rights.

- Users may download and print one copy of any publication from the public portal for the purpose of private study or research.
- You may not further distribute the material or use it for any profit-making activity or commercial gain
- You may freely distribute the URL identifying the publication in the public portal

If you believe that this document breaches copyright please contact us providing details, and we will remove access to the work immediately and investigate your claim.

## Linear Discrete-time State Space Realization of a Modified Quadruple Tank System with State Estimation using Kalman Filter

This content has been downloaded from IOPscience. Please scroll down to see the full text.

2017 J. Phys.: Conf. Ser. 783 012013

(<http://iopscience.iop.org/1742-6596/783/1/012013>)

View [the table of contents for this issue](#), or go to the [journal homepage](#) for more

Download details:

IP Address: 192.38.67.116

This content was downloaded on 23/03/2017 at 13:22

Please note that [terms and conditions apply](#).

# Linear Discrete-time State Space Realization of a Modified Quadruple Tank System with State Estimation using Kalman Filter

**Sazuan N M Azam**

Department of Applied Mathematics and Computer Science, Technical University of Denmark, DK-2800 Kgs. Lyngby, Denmark

E-mail: snaz@dtu.dk

**Abstract.** In this paper, we used the modified quadruple tank system that represents a multi-input-multi-output (MIMO) system as an example to present the realization of a linear discrete-time state space model and to obtain the state estimation using Kalman filter in a methodical manner. First, an existing dynamics of the system of stochastic differential equations is linearized to produce the deterministic-stochastic linear transfer function. Then the linear transfer function is discretized to produce a linear discrete-time state space model that has a deterministic and a stochastic component. The filtered part of the Kalman filter is used to estimate the current state, based on the model and the measurements. The static and dynamic Kalman filter is compared and all results is demonstrated through simulations.

## 1. Introduction

A dynamic model of a system can be described in a various way. From the derivation of the mathematical model it is possible to obtain the underlying information of the system and implement a control algorithm to the system. Most of the systems or processes are usually described by state-space system and by investigating the state of a system at certain time and its present and future inputs, it is possible to predict the output in the future [1]. State space models can be either non-linear or linear form and usually a real system or process is described by a non-linear models whereas in order to estimate and control the system, most mathematical tools are more accessible to a linear models. Therefore, in this paper we want to demonstrate the transformation of a non-linear continuous model of a modified quadruple tank system described as deterministic-stochastic differential equations into a linear discrete-time state space model.

Throughout this work, we will fully utilize the Modified Quadruple Tank System, based on [2] to assimilate the fundamental theory of model realization and state estimation to an exemplification of MIMO system, illustration of the real-world complex system applications which is widely used for education in modeling and demonstrating advanced control strategies [3], [4].

Several works have been done on four tanks system regarding the modeling the dynamic of the system. A full description of linearization of the model for four tank system is presented in [5], [6] and [7]. In [7] the linearization is described in detail using the Jacobian matrix formation to represent the system in state space model while in [8] establishes the linearized model based on the non-linear mechanism of the system. Another method is shown in [9] where the model is



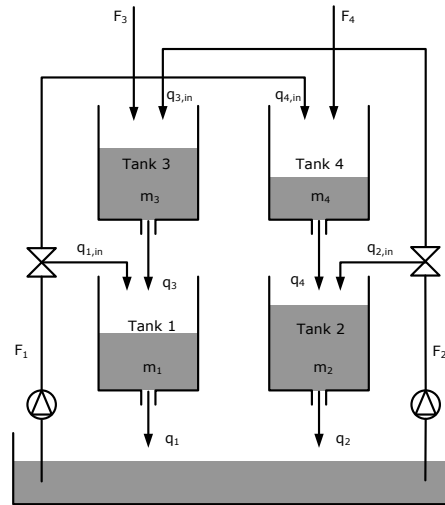

**Figure 1.** Schematic diagram of the modified quadruple tank process

developed from input and output data resulting an empirical linear state space model using a sub-space identification and can be used effectively for a non-linear system.

As for the state estimation, we want to estimates all the variables which represents the internal condition or the status of the system at a specific given time [1] so as to allow for future output prediction and to design the control algorithms. A Kalman's state estimator for a non-linear multivariable process such as the four tanks system is shown in [10] using a linear state space model solved by the algebraic Ricatti equation. Meanwhile the usage of the estimation of the Kalman filter with full derivation can also be found in [11]. In this work we use the Kalman filter in order to estimates the current state of the modified quadruple tank system and evaluate the response of dynamic and static Kalman filter.

This paper is structured as follows. A brief description of modified quadruple tank system is presented and the realization of the linear discrete-time state space model is shown in detail in Section 2. Then the state estimation using Kalman filter is discussed in Section 3. The following section is where all the results is discussed in Section 4. Finally, we conclude this work in the last section.

## 2. Linear Discrete-time State Space Model Realization

The first part of this paper is to transform the non-linear continuous state space model of a modified quadruple tank system to a linear discrete state space model through linearization and discretization. A brief description of the system is presented below and followed by the linearization and discretization.

### 2.1. The Modified Quadruple Tank System

The modified quadruple tank system is a simple process, consist of four identical tanks and two pumping system as shown in Figure 1 but yet illustrates a system that is non-linear with multiple inputs and outputs (MIMO) and complicated interactions between manipulated and controlled variables.

The main objective of this system is to control the level of the water in the lower tanks (Tank 1 and 2) by manipulating the flow rates  $F_1$  and  $F_2$  which are distributed across all four tanks, represents the dynamics of multivariable interaction since each manipulated variables influences the outputs. The height of the water level in these two tanks,  $h_1$  and  $h_2$  is measured and

controlled. The flows denoted  $F_3$  and  $F_4$  are unmeasured unknown disturbances.

The dynamic of the process is described in Stochastic Nonlinear Model (SDE) given as:

$$d\mathbf{x}(t) = f(\mathbf{x}(t), u(t), d(t), p)dt + \sigma d\mathbf{w}(t) \quad (1a)$$

$$\mathbf{y}(t) = c(\mathbf{x}(t)) + \mathbf{v}(t) \quad (1b)$$

$$\mathbf{z}(t) = c(\mathbf{x}(t)) \quad (1c)$$

where  $\mathbf{w}(t)$  is the process noise and normally distributed,  $\mathbf{w}(t) \sim N(0, R_w)$ , due to the unknown information regarding the distribution and  $\mathbf{v}(t)$  is the measurement noise from the sensors in each tank and it is normally distributed,  $\mathbf{v}(t) \sim N(0, R_v)$ .  $\mathbf{v}(t)$  is being added to the measured variables, (1b). For full description of the modeling part, see [12].

## 2.2. Linear System Realization

Linearization is required to find the linear approximation to analyze the behaviour of the nonlinear function, given a desired operating point. We apply the first-order term only of Taylor expansion by truncation around the steady state of the non-linear differential equations,  $f(x(t), u(t), d(t))$  and consider the derivative of the state variable,  $x$ . This derivative is defined as a function,  $f$ ,

$$f(x(t), u(t), d(t), p) = \begin{pmatrix} \rho\gamma_1 u_1(t) + \alpha_3 - \alpha_1 \\ \rho\gamma_2 u_2(t) + \alpha_4 - \alpha_2 \\ \rho(1 - \gamma_2)u_2(t) + \rho d_1(t) - \alpha_3 \\ \rho(1 - \gamma_1)u_1(t) + \rho d_2(t) - \alpha_4 \end{pmatrix} \quad (2)$$

where  $\alpha_i$  is given by

$$\alpha_i = \rho a_i \sqrt{x_i(t)} \sqrt{\frac{2g}{\rho A_i}} \quad i = 1, 2, 3, 4 \quad (3)$$

and  $p$  denote the vector containing all the parameters of the system, for full description of the parameter see [12]. The Jacobian of  $f$  with respect to the state-variables are

$$J_x(x(t), u(t), d(t), p) = \begin{pmatrix} -\beta_1 & 0 & \beta_3 & 0 \\ 0 & -\beta_2 & 0 & \beta_4 \\ 0 & 0 & -\beta_3 & 0 \\ 0 & 0 & 0 & -\beta_4 \end{pmatrix} \quad (4)$$

where  $\beta_i$  is given by

$$\beta_i = \frac{1}{\sqrt{x_i(t)}} \sqrt{\frac{a_i^2 g \rho}{2A_i}} \quad i = 1, 2, 3, 4 \quad (5)$$

Similarly the Jacobian of  $f$  with respect to the manipulated variables giving

$$J_u(x(t), u(t), d(t), p) = \begin{pmatrix} \rho\gamma_1 & 0 \\ 0 & \rho\gamma_2 \\ 0 & \rho(1 - \gamma_2) \\ \rho(1 - \gamma_1) & 0 \end{pmatrix} \quad (6)$$

and lastly the Jacobian of  $f$  with respect to the disturbance variables are

$$J_d(x(t), u(t), d(t), p) = \begin{pmatrix} 0 & 0 \\ 0 & 0 \\ \rho & 0 \\ 0 & \rho \end{pmatrix} \quad (7)$$

In this case, we introduced the deviation variables as

$$X(t) = x(t) - x_s \quad U(t) = u(t) - u_s \quad D(t) = d(t) - d_s \quad (8)$$

and defined the Jacobian matrices evaluated around a stationary point  $x_s, u_s, d_s$  to be

$$A_c = J_x(x_s, u_s, d_s, p) \quad B_c = J_u(x_s, u_s, d_s, p) \quad E_c = J_d(x_s, u_s, d_s, p) \quad (9)$$

With these matrices the first order Taylor approximation around the steady state point are given as

$$\begin{aligned} f(x(t), u(t), d(t), p) &\approx f(x_s, u_s, d_s, p) + A_c X(t) \\ &\quad + B_c X(t) + E_c D(t) \\ &= A_c X(t) + B_c X(t) + E_c D(t) \end{aligned} \quad (10)$$

For the measurement and controlled variables we introduced  $Y(t)$  and  $Z(t)$  respectively and the linearized system of the modified quadruple tank system as

$$\dot{X}(t) = A_c X(t) + B_c X(t) + E_c D(t) \quad X(t_0) = 0 \quad (11a)$$

$$Y(t) = C X(t) \quad (11b)$$

$$Z(t) = C_z X(t) \quad (11c)$$

where the  $C$  matrices are defined as

$$C = C_z = \begin{pmatrix} \frac{1}{\rho A_1} & 0 & 0 & 0 \\ 0 & \frac{1}{\rho A_2} & 0 & 0 \end{pmatrix} \quad (12)$$

### 2.3. Discretization of a Linear System

The dynamics of the modified quadruple tank system is now described as (11) and to use this linear continuous model of the system to be subjected to MPC, the model needs to be discretized by assuming zero-order-hold (ZOH) of the variables at specified sampling points, that is assuming the exogenous variables are constant between sampling points. The aim is to have a linear discrete-time state space model with piecewise constant  $u_k, d_k$  in a form of

$$x_{k+1} = A_d x_k + B_d u_k + E_d d_k \quad (13a)$$

$$y_k = C_d x_k + D_d u_k \quad (13b)$$

with discrete-time consideration

$$\begin{aligned} t_k &= t_0 + kT_s, & k &= 0, 1, 2, \dots \\ x_k &= x(t_k) \end{aligned}$$

and assuming the inputs on the ZOH is

$$u(t) = u_k, \quad t_k \leq t \leq t_{k+1}$$

then the solution of (13) with respect to  $u$  is given as

$$x_{k+1} = x(t_{k+1}) \quad (14a)$$

$$= e^{A(t_{k+1}-t_k)} x_k + \int_{t_k}^{t_{k+1}} e^{A(t_{k+1}-\tau)} B u(\tau) d\tau \quad (14b)$$

$$= [e^{AT_s}] x_k + \left[ \int_0^{T_s} e^{A\eta} B d\eta \right] u_k \quad (14c)$$

By comparing both equations (11) and (14) and similar result can be obtained for disturbances variable  $d(t)$  giving

$$\begin{aligned} A_d &= e^{AT_s} & B_d &= \int_0^{T_s} e^{A\tau} B d\tau & E_d &= \int_0^{T_s} e^{A\tau} E d\tau \\ C_d &= C & D_d &= D \end{aligned} \quad (15)$$

where  $A_d, B_d, E_d$  can be computed with

$$\begin{aligned} \begin{bmatrix} A_d & B_d \\ 0 & I \end{bmatrix} &= \exp \left( \begin{bmatrix} A & B \\ 0 & I \end{bmatrix} T_s \right) \\ \begin{bmatrix} A_d & E_d \\ 0 & I \end{bmatrix} &= \exp \left( \begin{bmatrix} A & E \\ 0 & I \end{bmatrix} T_s \right) \end{aligned} \quad (16)$$

For this particular work, the continuous state space representation matrices were discretized with  $T_s = 30s$  assuming ZOH.

Considering the stochastic part of the model, a piecewise constant process noise  $w$ , measurement noise  $v$  and uncertainty of the initial state  $x_0$  to the process is added. The linear discrete model from (13) is expanded into stochastic version as in the equation below

$$x_{k+1} = A_d x_k + B_d u_k + E_d (d_k + w_k) \quad (17a)$$

$$y_k = C_d x_k + v_k \quad (17b)$$

$$z_k = C_{dz} x_k + v_k \quad (17c)$$

subject to

$$x_0 \sim N(\bar{x}_0, P_p), \quad w_k \sim N(0, Q), \quad v_k \sim N(0, R) \quad (18)$$

where  $Q, R$  is given by

$$Q = \begin{bmatrix} 12.5^2 & 0 \\ 0 & 12.5^2 \end{bmatrix} \quad R = \begin{bmatrix} 2^2 & 0 & 0 & 0 \\ 0 & 2^2 & 0 & 0 \end{bmatrix}$$

and  $P_p$  is given by

$$P_p = \begin{bmatrix} 0.1^2 & 0 & 0 & 0 \\ 0 & 0.1^2 & 0 & 0 \\ 0 & 0 & 0.1^2 & 0 \\ 0 & 0 & 0 & 0.1^2 \end{bmatrix}$$

#### 2.4. Linear Discrete-time State Space Representation

In order to rewrite the difference equation system representation (13) in a more structured form, the Markov parameters is introduced. It is a discrete impulse coefficients of a discrete state space model. The Markov parameters are calculated to avoid making iterative simulations to keep only the matrix-vector multiplications. In doing so, a significant time saving is introduced to the control algorithm and to have an observer canonical form with minimal realization. Let  $H_i$  denote the Markov parameters at the  $i$ 'th sampling time after an unit-impulse, then to obtain the Markov parameters from  $u$  to  $y$  is given as

$$H_i = \begin{cases} 0 & i = 0 \\ CA_d^{i-1} B & i = 1, 2, \dots, N \end{cases} \quad (19)$$

$N$  is assigned value to be sufficiently large so that the impulse response can reach the steady state. The Markov parameters for  $u$  to  $z$ ,  $d$  to  $y$  and  $d$  to  $z$  is computed the same way and by

replacing the appropriate matrices accordingly. With all the information being gathered, it can be re-written in a matrix form of

$$Y = \Phi x_0 + \Gamma U \quad (20)$$

where  $Y$ ,  $\Phi$ ,  $U$  are

$$Y = \begin{bmatrix} y_1 \\ y_2 \\ y_3 \\ \vdots \\ y_i \end{bmatrix} \quad \Phi = \begin{bmatrix} CA_d \\ CA_d^2 \\ CA_d^3 \\ \vdots \\ CA_d^i \end{bmatrix} \quad U = \begin{bmatrix} u_1 \\ u_2 \\ u_3 \\ \vdots \\ u_i \end{bmatrix}$$

while  $\Gamma$  is obtained from the calculated Markov parameters,  $H_i$ ,  $i = 1, 2, \dots, N$

$$\Gamma = \begin{bmatrix} H_1 & 0 & 0 & \dots & 0 \\ H_2 & H_1 & 0 & \dots & 0 \\ H_3 & H_2 & H_1 & \dots & 0 \\ \vdots & \vdots & \vdots & & \vdots \\ H_N & H_{N-1} & H_{N-2} & \vdots & H_1 \end{bmatrix}$$

As for the system with disturbances, the state space model can be represented as

$$Y = \Phi x_0 + \Gamma_u U + \Gamma_d D \quad (21)$$

where

$$D = [d_1 \quad d_2 \quad d_3 \quad \dots \quad d_i]^T$$

From equations (20) and (21),  $\Phi$  and  $\Gamma$  can be used for the prediction part from the Kalman filter for a model predictive control strategy.

### 3. State Estimation for the Discrete-Time Linear System

From the previous section, the discrete-time state space model is a linearized model from the non-linear model. We want to extract information from the measurements of the real system in order to limit the discrepancy between the model and the real system but since the models assume measurement error, the signals need to be filtered. This can be done by using Kalman filter where it is used to filter the measurement [1]. The Kalman filter consists of two parts, filtering part and prediction part. The filtered part is to estimates current state based on the model and the measurements whilst the prediction part is used by the constrained regulator to predict the future output trajectory, given an input trajectory. This is illustrated in the block diagram as in Figure 2. In this paper we focus on the filtering part for the state estimation only and design both dynamic and static filter to evaluate their estimation.

#### 3.1. Dynamic Kalman Filter

From [12] the model is linear time invariant (LTI) discrete-time stochastic difference equations, in the form of

$$x_{k+1} = A_d x_k + B_d u_k + E_d d_k + E_d w_k \quad (22a)$$

$$y_k = C_d x_k + v_k \quad (22b)$$

subject to

$$w_k \sim N(0, Q), v_k \sim (0, R) \quad (23)$$



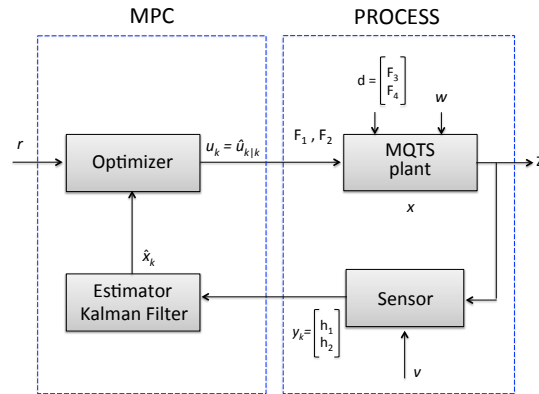

**Figure 2.** Block diagram of MPC for modified quadruple tank process

where the process noise  $w_k$  and measurement noise  $v_k$  are distributed as

$$\begin{bmatrix} w_k \\ v_k \end{bmatrix} \sim N_{iid} \left( \begin{bmatrix} 0 \\ 0 \end{bmatrix}, \begin{bmatrix} Q & S \\ S^T & R \end{bmatrix} \right) \quad (24)$$

where  $R$  and  $Q$  is the covariance matrix of measurement error and disturbances variable accordingly,  $S$  is the covariance matrix between disturbance variable and measurement error and the distribution of the initial state is given by

$$x_{0|-1} \sim N(\hat{x}_{0|-1}, P_{0|-1}) \quad (25)$$

Assuming at stationary point  $t = t_k$  and the measurement  $y_k = y(t_k)$ , the filtering part can be performed by calculating

$$\hat{y}_{k|k-1} = C\hat{x}_{k|k-1} \quad (26a)$$

$$e_k = y_k - \hat{y}_{k|k-1} \quad (26b)$$

$$\hat{x}_{k|k} = \hat{x}_{k|k-1} + K_{fx,k}e_k \quad (26c)$$

$$\hat{w}_{k|k} = K_{fw}e_k \quad (26d)$$

$$\hat{x}_{k+1|k} = A\hat{x}_{k|k} + Bu_k + \hat{w}_{k|k} \quad (26e)$$

By using the coefficients

$$R_{e,k} = CP_{k|k-1}C^T + R \quad K_{fx,k} = P_{k|k-1}C^TR_{e,k}^{-1} \quad K_{fw} = SR_{e,k}^{-1} \quad (27)$$

and the following expression can be achieved

$$P_{k+1|k} = AP_{k|k}A^T + Q_{k|k} - AK_{fx,k}S^T - SK_{fx,k}^TA^T \quad (28)$$

### 3.2. Static Kalman Filter

From equation (28) it can be re-written into a difference equation form as

$$P_{k+1|k} = AP_{k|k-1}A^T + Q - (AP_{k|k-1}C^T + S)(CP_{k|k-1}C^T + R)^{-1}(AP_{k|k-1}C^T + S)^T \quad (29)$$

$P$  signifies the stationary one-step ahead state error covariance matrix obtained from the Discrete-time Algebraic Riccati Equation (DARE).

$$P = APA^T + Q - (APC^T + S)(CPC^T + R)^{-1}(APC^T + S)^T \quad (30)$$

and the coefficients in equations (27) can be simplify

$$R_e = CPC^T + R \quad K_{fx} = PC^T R_e^{-1} \quad K_{fw} = SR_e^{-1} \quad (31)$$

Since by using this limit as an approximation to the one-step matrix and the Kalman gains  $K_{fx}$  and  $K_{fw}$  becomes constant matrices, it will lighten the computations of the controller.

#### 4. Results and Simulation of the system

The first part of this work is the linear discrete-time state space realization and computations which is re-written in a more structured form where we introduced the use of Markov parameters. Then the second part is the implementation of Kalman filter and the predictive controller strategy. In this sections, all results from the computations and simulations will be shown.

##### 4.1. Linear Discrete-time State Space Realization

The linearized continuous system matrices are obtained as in equation (11) to ensure that the theoretical linear estimation of the system are almost identical to the non-linear system, it is

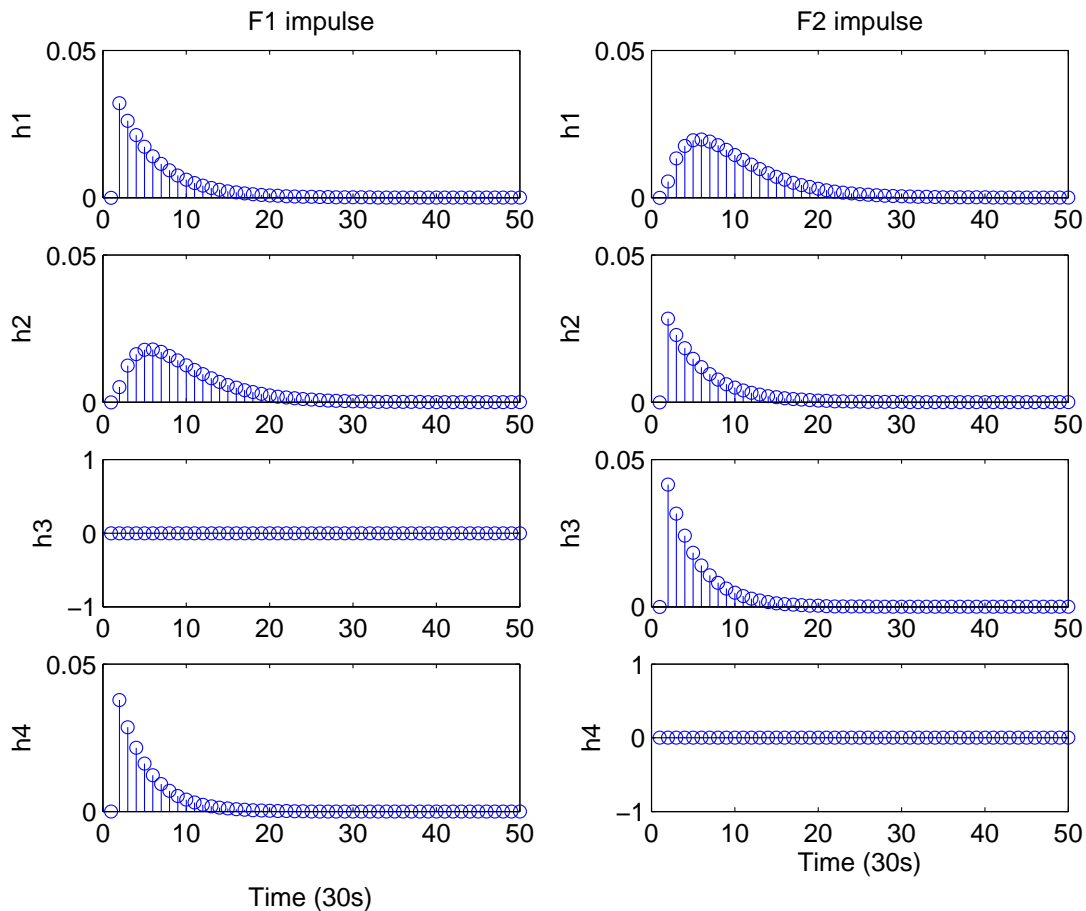

**Figure 3.** Markov Parameters for the Discrete-time State Space Model Experiments

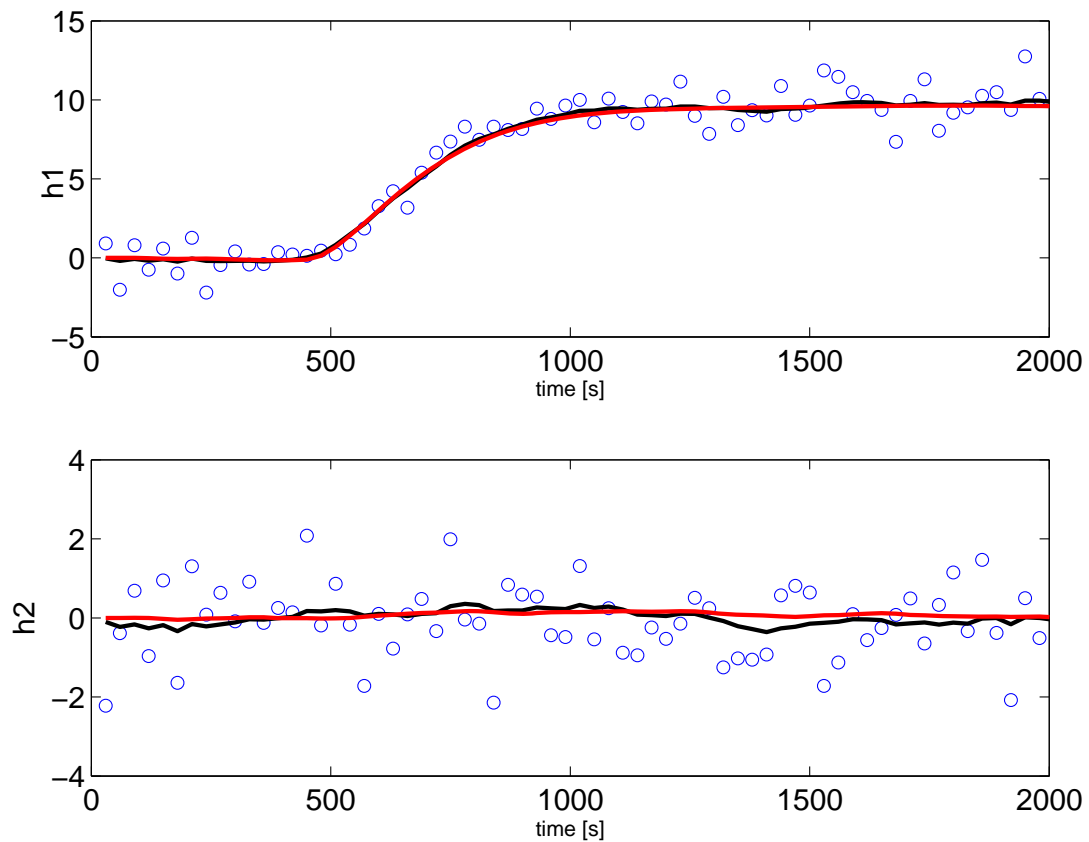

**Figure 4.** Kalman filter for noisy  $F_3$  and 10% step changes

possible to compare the estimated gains and time-constants from the non linear transfer function. Then, by assuming zero-order hold, the continuous state space representation matrices above were discretized with  $T_s = 30s$ , hence the discrete state space system matrices is also obtained as in equation (13).

Considering a sampling time of  $T_s = 30s$  the Markov parameters has been calculated for the discrete-time state space model, from Figure 3 the plots can be compared to the model from the step response experiment in our previous work [12] and shows that in most cases the plots are very similar. Therefore, the calculated Markov parameters,  $H_i$  are reliable and usable for other purposes such as in designing the predictive controller.

#### 4.2. State Estimation

In this experiments, both dynamic and static Kalman filter were tested as a state estimator where the disturbance is an unknown stochastic variable, then after approximately 450s we introduced a 10% step changes and for this simulations, the linear model is used to create the measurements. Figure 4 and Figure 5 were plotted to compare the estimated current states with and without Kalman filter and between dynamic and static Kalman filter with a step change of  $F_3$  and  $F_4$  accordingly. It can be clearly seen that in general, the filter is well performed tracking the output trajectory from the noisy measurements and also it can cope well dealing with an impact of the unknown disturbance step. Although the difference between dynamic and static Kalman filter is not apparent, the dynamic filter is able to even further reduce the noise giving a smoother and more stable response particularly in tanks  $h_1$  in figure 4 and tank  $h_2$  in figure 5, noticeable for both tanks that is directly affected by the given step disturbance.

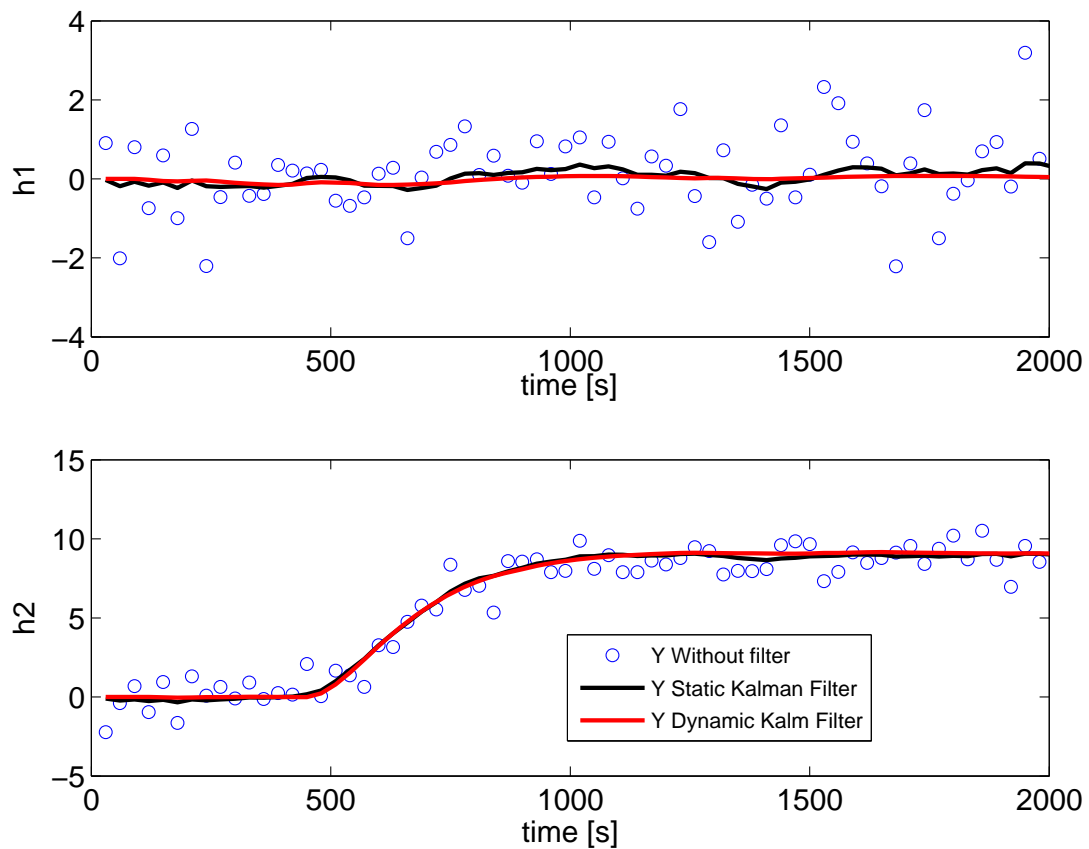

**Figure 5.** Kalman filter for noisy  $F_4$  and 10% step changes

## 5. Conclusion

This paper has described comprehensively an outline to obtain a discrete-time state space model for a linear system on a modified quadruple tank system in a simple and constructive method. This lab scale system represents a MIMO system which has complicated variables interactions and complex control problems. The dynamics of the system is described by an existing simulation model in terms of deterministic and stochastic non-linear continuous time models. These models were linearized and discretized in order to form a discrete-time linear time-invariant difference equations, the form that is used in the Kalman Filter for estimations. Based on the model and measurements, the current state of the system was estimated and in addition, the comparison between dynamic and static Kalman filter was also presented.

## Acknowledgement

This work was supported by Faculty of Electrical Engineering, Universiti Teknikal Malaysia Melaka, Durian Tunggal, 76100, Malaysia and the Ministry of Higher Education, Malaysia.

## References

- [1] Simon D 2006 *Optimal State Estimation* (John Wiley & Sons)
- [2] Johansson K H 2000 *IEEE Transactions on Control Systems Technology* **8** 456–465
- [3] Johansson K H, Horch A, Wijk O and Hansson A 1999 *Proceedings of the IEEE Conference on Decision and Control* **1** 807–812
- [4] Dormido S and Esquembre F 2003 *European Control Conference (ECC), 2003* (IEEE) pp 3267–3272

- [5] Askari M, Moghavvemi M, Almurib H A F and Muttaqi K M 2016 *IEEE Transactions on Industry Applications* **52** 1882–1890
- [6] Almurib H A F, Askari M and Moghavvemi M 2011 *Proceedings of the Sice Annual Conference* 6060581, 87–91
- [7] J J, T S and Babu T H 2014 *International Journal of Advanced Research in Electrical, Electronics and Instrumentation Engineering, IJAREEIE* **03** 11552–11565
- [8] Prusty S B, Pati U C and Mahapatra K K 2015 *Computer, Communication, Control and Information Technology (C3IT), 2015 Third International Conference on (IEEE)* pp 1–6
- [9] Gatzke E P, Meadows E S, Wang C and Doyle F J 2000 *Computers & Chemical Engineering* **24** 1503–1509
- [10] Vijula D A and Devarajan N 2013 *International Journal of Electrical Engineering and Technology* **6** 149–163
- [11] Jorgensen J B and Jorgensen S B 2007 *2007 American Control Conference (IEEE)* pp 128–133
- [12] Mohd Azam S N and Jørgensen J B 2015 *Proceedings of the 5th International Conference on Control Systems, Computing and Engineering (ICCSCE 2015)*