



## Product Maturation Guide - A Digital Simulation Outcome

**Boorla, Srinivasa Murthy; Howard, Thomas J.**

*Published in:*  
Procedia C I R P

*Link to article, DOI:*  
[10.1016/j.procir.2016.02.044](https://doi.org/10.1016/j.procir.2016.02.044)

*Publication date:*  
2016

*Document Version*  
Publisher's PDF, also known as Version of record

[Link back to DTU Orbit](#)

*Citation (APA):*  
Boorla, S. M., & Howard, T. J. (2016). Product Maturation Guide - A Digital Simulation Outcome. *Procedia C I R P*, 43, 82-87. <https://doi.org/10.1016/j.procir.2016.02.044>

---

### General rights

Copyright and moral rights for the publications made accessible in the public portal are retained by the authors and/or other copyright owners and it is a condition of accessing publications that users recognise and abide by the legal requirements associated with these rights.

- Users may download and print one copy of any publication from the public portal for the purpose of private study or research.
- You may not further distribute the material or use it for any profit-making activity or commercial gain
- You may freely distribute the URL identifying the publication in the public portal

If you believe that this document breaches copyright please contact us providing details, and we will remove access to the work immediately and investigate your claim.

14th CIRP Conference on Computer Aided Tolerancing (CAT)

## Product Maturation Guide - a digital simulation outcome

Boorla S Murthy, Thomas J Howard

*Department of Mechanical Engineering, DTU, Lyngby 2800, Denmark  
Department of Mechanical Engineering, DTU, Lyngby 2800, Denmark*

\* Corresponding author. Tel.: +45 81940143. E-mail address: [skimbo@mek.dtu.dk](mailto:skimbo@mek.dtu.dk), [murthy.boorla@gmail.com](mailto:murthy.boorla@gmail.com)

### Abstract

The process of improving product performance by improving individual parts and tuning the assembly line fixtures to reach acceptable quality to start mass production is called Product Maturation. Often in new product development, product maturation affects the target date due to iterative process. Tolerance analysis tools, those optimizing the individual part tolerances at the time of design can generate a *product maturation guide* that eliminates many problem solving procedures and saves time on root cause analysis. Assume a first product built on a new assembly line was found to need improvements. To conclude the actions we need information about all the dimensions of child parts and processes involved and their influence. At the time of product design, the tolerance analysis system works with the same variables with a given range of variations virtually. For a practical build, instead of variation range, it has to consider one fixed value measured from initial parts. By adding information about process characteristics, like speed, cost, etc. to all the dimensions, the system can directly guide the manufacturing team, on which parameter to modify, which direction and how much. At the same time, it can predict the time required and cost involved. Product Maturation guide is one of the documents/tools that gets passed from design to manufacturing along with 3D models and drawings at the manufacturing kick-off gate. Tolerance analysis tools can make it possible to reduce product maturation time by 80%.

© 2016 The Authors. Published by Elsevier B.V. This is an open access article under the CC BY-NC-ND license (<http://creativecommons.org/licenses/by-nc-nd/4.0/>).

Peer-review under responsibility of the organizing committee of the 14th CIRP Conference on Computer Aided Tolerancing

*Keywords:* Tolerance. Analysis, Product, Maturation

### 1. Introduction

Once a product design is finalized, manufacturing starts developing parts and assembly line. A product goes through several phases, Proto, Pilot, Alpha, Beta, etc. before establishing mass production. This process of improving individual parts through modifying tools and tuning the assembly line fixtures to reach product quality acceptable to mass production is called Product Maturation. Each phase of maturation is defined with certain aspects of the product to be confirmed. Not meeting them in one iteration leads to stretching the phase, like alpha1, alpha2, alpha3, etc. This pushes the Start Of Production (SOP) date further past the launch date. The key intent of all these phases is to understand each part dimension and their behavior in assembly. Also

assembly line fixtures are tuned with respect to individual parts to meet assembly dimensions over the phases. This research focuses on the process of improving parts and fixtures by understanding their design philosophy, allowing the manufacturing team to take all improvement actions together, and reduces maturation time to reach SOP.

Product design involves two aspects before kicking-off manufacturing.

1. Geometry: Size, shape and their control requirements to meet the product functions. Control requirements get communicated to manufacturing through, drawings and 3D math models. The designer's assumption behind this specification system is that, when

manufacturing meets all the part dimensions, the final product will meet the targets automatically.

2. Assembly process: The method of joining the parts for making sub-assemblies and final assembly. Process design communication to manufacturing specifies where to hold the parts and where and what kind of joint to apply. The assumption is that when manufacturing follows the process specification, final assembly will meet the functions automatically.

In this traditional way of passing the product from design to manufacturing, “how” all these dimensions are working together with the process and achieving the final target is not included. As manufacturing tries to follow all the specifications independently, with less understanding of their relationship, it leads to iterations. They need to learn the relationship over failures. Instead, design communication can include the philosophy behind all the dimensions, can speed up the maturation. Developing a maturation guide from the same variation analysis tool used for product design, can help the manufacturing team make all improvements in one go with predictable performance.

Researches in the past developed the tolerance analysis methods to predict product variations. Greenwood and Chase [1,2] suggested tolerance methods to analyse the assembly issues. Assembly tolerance optimization techniques have been derived by DeDoncker and Spencer [3]. Approaches of commercial software in tolerance analysis have been explained by Turner and Gangoiti [4]. An algorithm developed by XiongY and RongR [5] for predicting geometric variation in assembly. The process of identifying source of variation from assembly condition has been developed by Hu and Wu [6]. Ayne Cai [7] suggested a two-step approach for understanding part geometry and position variations in assembly. The research of Wenzhen and Zhenyu [8] included assembly fixture variations in the final product. This paper connecting assembly variations on product functional requirements also focused on dedicated outcome for product maturation.

## 2. Method

This research followed a method of understanding present industry practice, finding the motivations for iterations at maturation, identifying the gap, finding gap filling opportunities. Fig 1 shows the method followed.

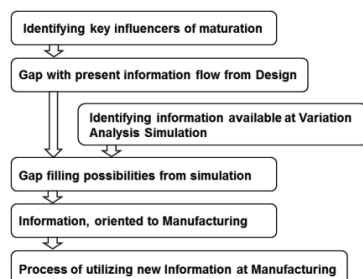

Fig 1. Research method to improve maturation process

### 2.1 Traditional Maturation Process

Once the parts are confirmed in their production process and dimensionally within tolerance from their drawings, the first batch of products gets built. When products are tested and some of the performance targets are not met, parts go for improvement. The order of priority for addressing targets is,

1. Performances out of quality limits
2. Performances near to the quality limits

When all the performances are reached within the acceptance range, the focus moves to high value performances to keep near to nominal. Traditional maturation processes look for easy and quick solutions to correct product performances. First, process and fixture parameters are adjusted according to parts. When that is not sufficient, part dimensions are changed. Due to the coupled conditions of design, changes to one product performance also influence other performances, which are not planned to change. This leads to the next cycle of iteration.

The top three motivations for iterative cycles noted from manufacturing records are analyzed to find gaps.

1. Not knowing the relationship of change in dimension to change in performance: Sometimes modification in one dimension gives less improvement in performance than expected. This leads to change in the same dimension again. Sensitivity of dimension is not considered while applying changes.
2. One dimension change influences multiple product performances in various degrees: While improving some performances, others go down, which demands changing the same dimensions again. The coupled condition of performances is not completely known to manufacturing.
3. Many final product specifications are not dimensions, for example, push button force, door closing efforts, uniformity across the product, etc. Unless products are tested, manufacturing will not know the exact performance achieved. Iterations go on to improve the product after testing. Mathematical relationships with dimensions to end product specifications are not applied at maturation.

All these gaps, sensitivity, coupling and mathematical relationships are part of product design philosophy. Variation analysis, performed at the design stage, generates the relationship of all dimensions in the product, including assembly fixtures. For complex products 3 Dimensional (3D) tolerance analysis tools are used. These digital tools build the transfer functions between each dimension and the corresponding final product performances. An outcome from these digital tools, in manufacturing understandable format, can enhance the maturation process.

2.2 Simulation outcome

Variation analysis tools accepts, all geometry controls and build processes as inputs and calculate the final assembly variation. But product specifications are not assembly dimensions, those are only related. A product design process of relating part level Design Parameters (DP) to product Functional Requirements (FR) is with mathematical models through final product assembly Dimensional Targets (DT). Fig2 shows the representative diagram of the DP to FR relationship.

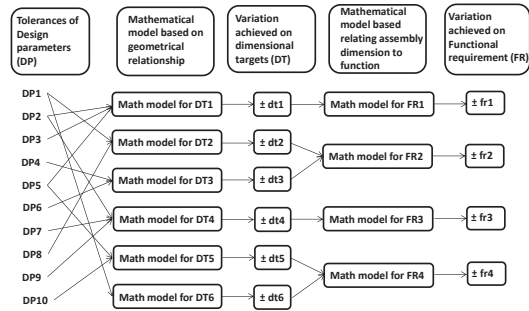

Fig 2. Design process relating DPs to FRs

Variation Analysis Simulation (VAS) generates mathematical models of all DTs. Mathematical models of FRs are derived from the design concept. Typically the contribution of VAS tools ends by giving DTs variation. Some of the tools accept mathematical models of FR as input and extend their output up to FR variation. Tools also offer DPs optimization by accepting target FR variation in the opposite direction.

Note: VAS digital tools work on the principles of statistical tolerance analysis like Worst Case, Root sum square, Monte Carlo, etc. These tools allow for selecting input variables with their distribution nature. These are capable of understanding various types of tolerances and calculating the impact of each variable to the final product. The few commercial tools available are 3DCS[8], VSA[9],CeTol[10], etc.

Fig 3 shows the cycle of variation and optimization.

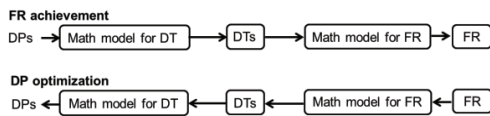

Fig 3 Cycle of FRs achievement and DPs optimization at design

The same cycle of variation and optimization performed at design is required to fill the gaps in manufacturing during maturation. At the time of design, input parameters are theoretical and with a specified range of tolerance, but at maturation those are actual part measurements. As all the information is within the VAS system, a specific manufacturing oriented outcome provides

the same cycle opportunity at product maturation. Fig 4 shows the replicated cycle for manufacturing.

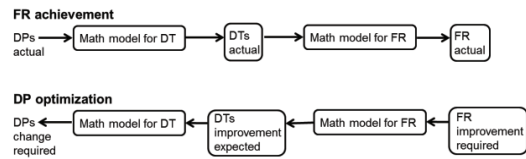

Fig 4 Cycle of FRs achievement and DPs optimization at maturation

3. Case study

A simplified concept of an injection device shown in Fig 5 and Fig 6 provides a case study.

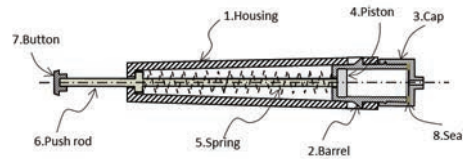

Fig 5. A simplified concept of an injection device

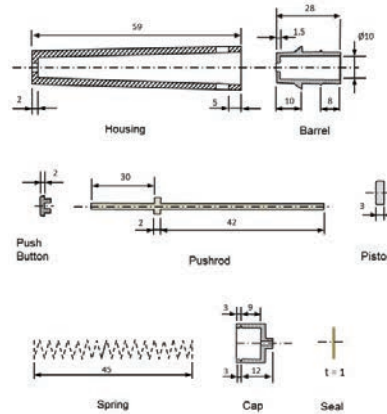

Fig 6 Dimensions related to study of each part

After completing the variation and optimization cycles of design, DPs contributions in DTs and further FRs are calculated. Mathematical models derived by VAS are within the tolerance model. The designer concludes the assembly DTs and FRs as design stage achievement and sets them as production targets. Designer communication to manufacturing is through drawings and 3D models. At the time of development, initial products allow for an understanding of the parts' dimensional status and their performance in assembly. Parts are ensured to reflect mass production process characteristics with a statistically suitable number of trails. Mean values of all parts and their connected dimensions are shown in Fig 7. A generic approach of new tool development is to maintain a “metal safe“ condition. This safety factor makes the mean values of the parts distinct from nominal, even though they are within tolerance.

Part	Dimension	Tol	Mean of Measurement	Deviation	Status
Housing	59	±0,5	59,35	0,35	OK
	2	±0,3	1,80	-0,20	OK
	5-upper	±0,2	4,90	-0,10	OK
	5-lower	±0,2	5,05	0,05	OK
Barrel	28	±0,5	28,30	0,30	OK
	10	±0,3	9,80	-0,20	OK
	8-upper	±0,2	8,05	0,05	OK
	8-lower	±0,2	7,95	-0,05	OK
	∅10	±0,3	10,20	0,20	OK
	1,5	±0,2	1,40	-0,10	OK
Piston	3	±0,2	2,90	-0,10	OK
Cap	12	±0,5	11,75	-0,25	OK
	9	±0,2	8,90	-0,10	OK
	3-upper	±0,1	2,90	-0,10	OK
	3-lower	±0,1	3,00	0,00	OK
Push rod	2	±0,2	1,90	-0,10	OK
	30	±0,3	30,20	0,20	OK
Button	2	±0,3	2,20	0,20	OK
Spring	45	±1	44,50	-0,50	OK
Seal	1	±0,05	1,00	0,00	OK

Fig 7 Inspection report of first batch parts. All dimensions are within tolerance limits specified in the drawing

Assemblies and their product functional performances are shown in Fig 8. FRs are prioritized for actions. The results of first iteration give improvements in priority functions, but that may also improve or reduce non-priority ones. Sometimes, this leads to work on priority items once again.

Priority	FR	Nominal	Tol	Mean Performance	Deviation	Status
1	Filling capacity (ml)	1845	±114	1960	115	Not OK
2	Push button Force (N)	1,5	±0,37	1,06	-0,44	Not OK
3	Gap Uniformity (mm)	0	±0,3	0,35	0,35	Not OK
4	Gap (mm)	2	±0,6	2,8	0,8	Not OK
5	Overall length (mm)	106	±1,1	107,4	1,4	Not OK

Fig 8 Mean product performances estimated from first set of assemblies. Deviation higher than Tol value status of FRs turns to Not OK

Note: Every function of the product gets prioritized with its purpose. Various techniques like Quality Function development [11] are available to arrive priority list.

Considering the time related deterioration, the start of production gets targeted to keep all the performances nearer to the nominal. This requires fine tuning the product even with minor tool changes. For these conditions a product maturation guide generated by VAS gives the opportunity to calculate the exact modification of which part, which dimension, how much and which direction.

#### 4. Results

Simulating the case, the maturation guide expected from the VAS system is shown in Fig 9. This predicted product performance accepted part measurements as input and used the mathematical model developed during design optimization. When performances are out of the acceptance criteria, the system highlights in Red. Using this interface, the engineer can find the changes required in DPs to bring one, more or all the performances into the limits in one simulation. As the cost and time impacts of each dimension are fed in

before, the system can provide the impact of changes along with suggestions. This allows for cost and time effective solutions independently.

Note: The relationship equation of DPs and FRs is derived through the design concept. For example, push button force variation is the result of spring compression change multiplied by spring constant.

Maturation guide works on the same principles of tolerance optimization during design. When FR improvement is required, the system follows the checklist in hierarchy.

1. Which DP is highly contributing?
  - 1.1 Is that DP contributing in other FRs?
  - 1.2 Is that complimenting or contradicting?
  - 1.3 Contribution change in each FR per unit DP change.
2. Does the DP have interactions with other DPs?
  - 2.1 Which DP contribution changes and how much?
  - 2.2 Does the contribution of other DPs increase or decrease?

Additional checks for manufacturing:

3. Time required to change the DP?
  - 3.1 Rate of change in time per unit DP change?
4. Expense of the DP change?
  - 4.1 Rate of change in expense per unit DP change?

Fig 10 shows the system suggested changes after simulating with actual part values. The VAS guides on which dimension to change, how much and in which direction.

The system identified three particular DPs to modify to bring all the FRs into the limit. There can be multiple solutions to improve FRs, but VAS chooses the DPs that best compliment all the FRs and other DPs.

This interface of VAS works in the best interests of manufacturing. The first change suggested by the system is to reduce the Barrel length from 28.3 to 28.1. This addresses the high priority requirement of filling capacity. However filling capacity can be addressed in other DPs, barrel diameter or thickness and also by piston thickness. The suggested change compliments other FRs. The gap also comes within limits and overall length is also improves. Quantity of change of 0.2 length reduction is the result of the mathematical relationship defined at the design stage.

The second change of spring length, addresses the second priority FR, push button force. This also can be achieved by changing the housing or barrel and also by push rod dimensions. The system suggested spring change is due to its process nature being quickest and cheapest for resetting the spring length.

The third change is to improve the other two FRs, Gap uniformity and Overall length. The system suggested upper snap feature in housing to match the lower. Uniformity can be

brought by changing the other two places at barrel or at cap, but the suggested change compliments overall length and brings both of them into the acceptance limit. Also change has less time and cost impact due to the work being limited to only on insert, not on the main mold.

Sometimes the system may suggest one dimension to deviate more from nominal to compensate the other, because changing the other takes more time.

Parts	Functional Requirement ----->			Filling capacity	Push button force	Gap Uniformity	Gap	Overall length	Change impact	
	Design Parameter	Tol	Part measurement						Time ( days)	Cost (€)
	Functional Requirement ----->			1845ml ±114	1,50 N ±0,37	0mm ±0,3	2,0mm ±0,6	106mm ±1,1		
	Product Performance achieved ----->			1960	1,065	0,35	2,80	107,40		
	Final assembly dimension achieved ----->			1960	3,55	0,35	2,80	107,40		
Housing	59	±0,5	59,35		59,35			59,35		
	2	±0,3	1,8		1,80			1,80		
	5-upper	±0,2	4,9		4,90	4,90	4,90	4,90		
	5-lower	±0,2	5,05			5,05				
Barrel	28	±0,5	28,3	28,30			28,30	28,30		
	10	±0,3	9,8		9,80			9,80		
	8-upper	±0,2	8,05			8,05				
	8-lower	±0,2	7,95			7,95				
	∅10	±0,3	10,2	10,20						
Piston	1,5	±0,2	1,4	1,40						
	3	±0,2	2,9	2,90						
Cap	12	±0,5	11,75					11,75		
	9	±0,2	8,9				8,90	8,90		
	3-upper	±0,1	2,9			2,90	2,90			
	3-lower	±0,1	3			3,00				
Push rod	2	±0,2	1,9		1,90					
	30	±0,3	30,2					30,20		
Button	2	±0,3	2,2					2,20		
Spring	45	±1	44,5		44,50					
Seal	1	±0,05	1				1,00	1,00		

Fig 9. Performance prediction with actual parts dimensional achievement. All the FRs of the first batch parts out of limits are highlighted in red.

The manufacturing engineer can ask VAS for the DP changes to bring all the FRs within 10% of deviation from their nominal. The engineer will be able to choose the quickest and also the most cost effective change, with quantity and direction.

This conceptual example adapted from a mass production injection device has a history of 5 iterations with 50% of DPs changed. Applying the maturation guide proves the possibility of making it in one iteration, with improved predictability, saving 80% maturation time.

Parts	Functional Requirement ----->			Filling capacity	Push button force	Gap Uniformity	Gap	Overall length	Change impact	
	Design Parameter	Tol	Part measurement						Time ( days)	Cost (€)
	Functional Requirement ----->			1845ml ±114	1,50 N ±0,37	0mm ±0,3	2,0mm ±0,6	106mm ±1,1		
	Product Performance achieved ----->			1944	1,17	0,20	2,45	107,05		
	Final assembly dimension achieved ----->			1944	3,90	0,20	2,45	107,05		
Housing	59	±0,5	59,35		59,35			59,35		
	2	±0,3	1,8		1,80			1,80		
	5-upper	±0,2	5,05	3	5,05	5,05	5,05	5,05	2	2000
	5-lower	±0,2	5,05			5,05				
Barrel	28	±0,5	28,1	28,10			28,10	28,10	5	3000
	10	±0,3	9,8		9,80		9,80	9,80		
	8-upper	±0,2	8,05			8,05				
	8-lower	±0,2	7,95			7,95				
	∅10	±0,3	10,2	10,20						
Piston	1,5	±0,2	1,4	1,40						
	3	±0,2	2,9	2,90						
Cap	12	±0,5	11,75					11,75		
	9	±0,2	8,9				8,90	8,90		
	3-upper	±0,1	2,9			2,90	2,90			
	3-lower	±0,1	3			3,00				
Push rod	2	±0,2	1,9		1,90					
	30	±0,3	30,2					30,20		
Button	2	±0,3	2,2					2,20		
Spring	45	±1	44,7		44,70				1	500
Seal	1	±0,05	1				1,00	1,00	5	5500

Fig 10 . System suggested changes in three DPs are highlighted in yellow. Impact of those changes time and cost are calculated based on previously fed details of those manufacturing processes.



## 5 Discussion

Most of the prior research is focused on using actual part readings and predicting the final assembly dimensions, but not connected to product performances. Some tools accept part measurements and mathematical models to predict performance values. These allow for checking the impact of DP changes independently, but do not optimize DPs for manufacturing. This research aimed to make the VAS interface more manufacturing friendly with a dedicated outcome for the product maturation stage. In this, DPs optimization approach is manufacturing favorable. A key success factor is creating a maturation guide interface to carry the tolerance optimization cycle done at the design stage. This does not demand additional tools within the organization. One system linked to Design and Manufacturing allows product updates linked.

Time and cost information requires feeding into the system before maturation guide preparation as it is generic and usually exists within manufacturing. For example, the time required for any dimension change depends on how and where that got produced. In mold, it may take longer, but in post processing it takes less time. Sometimes, at the supplier end it takes a long time, and in-house takes less time. Similarly cost aspects are fed in.

The same system can be extended after maturation as a monitoring system for mass production, which allows entering all the regular inspection data and predicting performance live. Once the prediction confidence is established, the product testing requirement gets reduced.

## 6. Conclusion

For complex products with more parts, the maturation guide is highly beneficial. For example, a gap between tail lamp to tail gate in an automotive assembly has several parts and processes involved. Even though the variations are minor at parts level, the impact of them on final assembly might be high due to geometrical spread. Lamps mounting direction and its gap measuring directions will not be the same for correlating the changes directly. Maturation guide provides a broader picture of all FRs and all DPs and suggests the best possible solution. VAS interface can also be added for more product characteristics, like stresses in the parts after assembly. When stresses are counted, that can estimate possible deteriorations over time, and predict Noise, Vibration and Harshness (NVH) issues, retaining the newness of the product, etc. Further research on robust maturation guide and extending to the production monitoring system is in progress.

## 7. Acknowledgment

The authors would like to acknowledge Novo Nordisk for the research funding under the DTU-Novo Nordisk Robust Design Programme.

## 8. References

- [1].Greenwood, W. H., and K. W. Chase. "A new tolerance analysis method for designers and manufacturers." *Journal of Engineering for Industry* 109.2 (1987): 112-116.
- [2].Chase, Kenneth W., and William H. Greenwood. "Design issues in mechanical tolerance analysis." *Manufacturing Review* 1.1 (1988): 50-59.
- [3].DeDoncker, Dwight, and Al Spencer. "Assembly tolerance analysis with simulation and optimization techniques." No. 870263. SAE Technical Paper, 1987.
- [4].Turner, J., and A. B. Gangooiti. "Tolerance analysis approaches in commercial software." *Concurrent Engineering* 1.2 (1991): 11-23.
- [5].Xiong, C., et al. "Geometric variation prediction in automotive assembling." *Assembly Automation* 22.3 (2002): 260-269.
- [6].Hu, S. Jack, and S. M. Wu. "Identifying sources of variation in automobile body assembly using principal component analysis." *Trans. NAMRI/SME* 20 (1992): 311-316. .
- [7].Cai, Wayne. "A new tolerance modeling and analysis methodology through a two-step linearization with applications in automotive body assembly." *Journal of Manufacturing Systems* 27.1 (2008): 26-35.
- [8].3DCS.Dimensional Control Systems,Inc. <http://www.3dcs.com>
- [9].VSA.Siemens. <http://www.plm.automation.siemens.com/>
- [10].CE/TOL6\_. Sigmatrix LLC. <http://www.sigmatrix.com/>.
- [11].Chen, Chung-Yang, Li-Chieh Chen, and Li Lin. "Methods for processing and prioritizing customer demands in variant product design." *Iie Transactions* 36.3 (2004): 203-219.
- [12] Gao, Jinsong, Kenneth W. Chase, and Spencer P. Magleby. "Generalized 3-D tolerance analysis of mechanical assemblies with small kinematic adjustments." *IIE transactions* 30.4 (1998): 367-377.
- [13] Ashiagbor, A., H-C. Liu, and B. O. Nnaji. "Tolerance control and propagation for the product assembly modeller." *International Journal of Production Research* 36.1 (1998): 75-94.
- [14] Söderberg, Rikard, Kristina Wärmefjord, and Lars Lindkvist. "Variation simulation of stress during assembly of composite parts." *CIRP Annals-Manufacturing Technology* 64.1 (2015): 17-20.