



## Defence plans and restoration

**Sørensen, Poul Ejnar; Das, Kaushik; Llopis, Regina ; Gaitán, Vicens; Halat, Milenko ; Zamarreño, Luis María ; Van Hertem, Dirk; De Boeck, Steven; Hillberg, Emil ; Turunen, Jukka**

*Total number of authors:*  
16

*Publication date:*  
2014

[Link back to DTU Orbit](#)

### *Citation (APA):*

Sørensen, P. E. (Author), Das, K. (Author), Llopis, R. (Author), Gaitán, V. (Author), Halat, M. (Author), Zamarreño, L. M. (Author), Van Hertem, D. (Author), De Boeck, S. (Author), Hillberg, E. (Author), Turunen, J. (Author), Vanfretti, L. (Author), Leelarujji, R. (Author), Vieyra, R. A. M. (Author), Moreira, C. (Author), Madureira, A. (Author), & Seca, L. (Author). (2014). Defence plans and restoration. Sound/Visual production (digital), Technical University of Denmark.

---

### General rights

Copyright and moral rights for the publications made accessible in the public portal are retained by the authors and/or other copyright owners and it is a condition of accessing publications that users recognise and abide by the legal requirements associated with these rights.

- Users may download and print one copy of any publication from the public portal for the purpose of private study or research.
- You may not further distribute the material or use it for any profit-making activity or commercial gain
- You may freely distribute the URL identifying the publication in the public portal

If you believe that this document breaches copyright please contact us providing details, and we will remove access to the work immediately and investigate your claim.

# Defence plans and restoration

Poul Sørensen and Kaushik Das, Technical University of Denmark  
Regina Llopis, Vicens Gaitán, Milenko Halat and Luis María Zamarreño, AIA  
Dirk Van Hertem and Steven De Boeck, KU Leuven  
Emil Hillberg and Jukka Turunen, Statnett  
Luigi Vanfretti and Rujiroj Leelaruji, KTH  
Rodrigo Andres Moreno Vieyra, Imperial Collage  
Carlos Moreira, André Madureira and Luis Seca, INESC Porto

# ENTSO-E definition

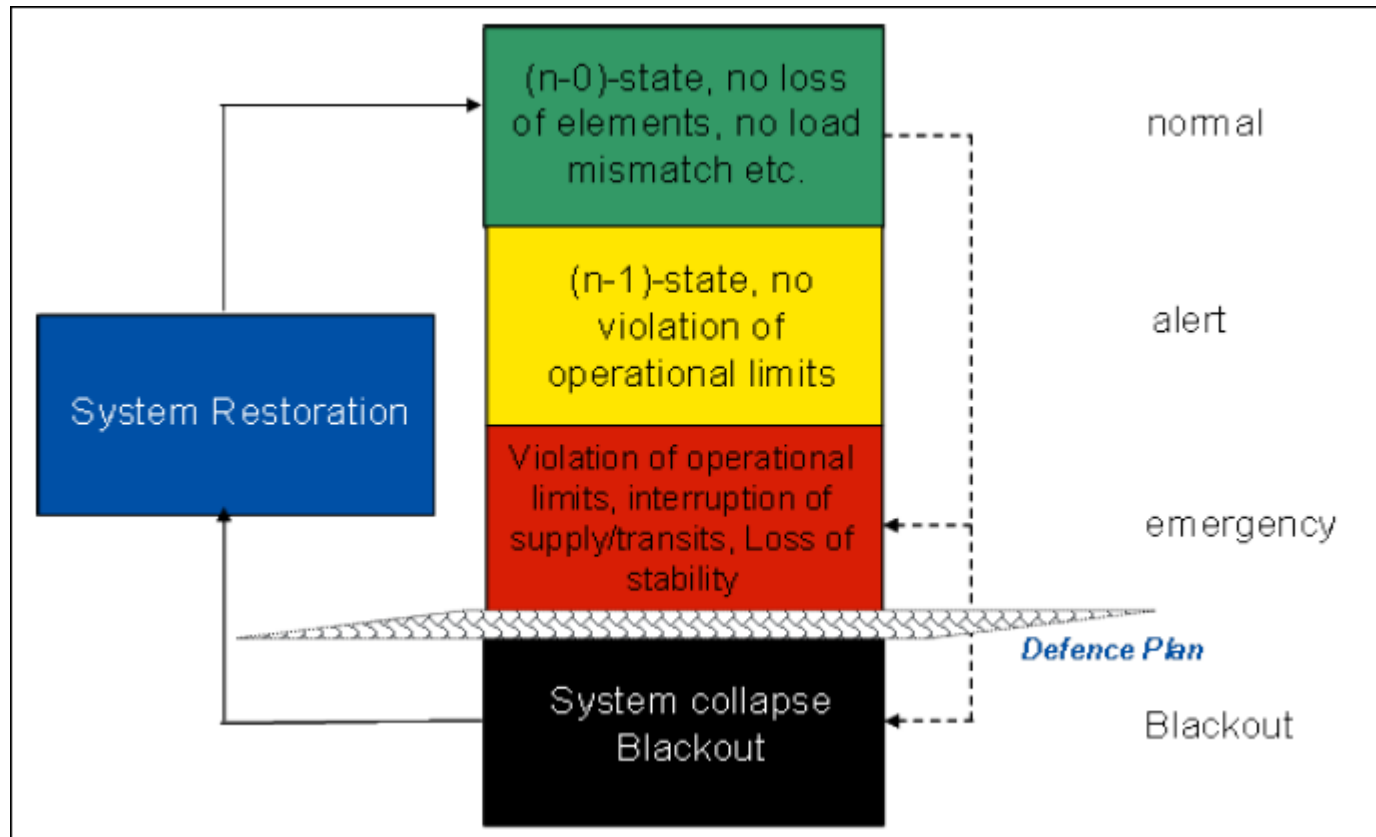

# Workplan defense / restoration

- Defense plans
  - Weak points in existing plans (AIA)
  - Role of renewable generation plants (DTU)
  - Pan-European coordination (KU Leuven)
  - Use of PMUs (Statnett / KTH)
  - Use of distributed energy resources (Imperial Col.)
- Restoration
  - Coordinated restoration (AIA)
  - Use of renewable generation plants (INESC)

# Detection of weak points of defense plans in the pan-European grid

- First part of the work consisted in gathering, comparing and analyzing information about TSO's practices
  - Specific survey.
  - Visits to TSOs.
- The second part will involve the study of scenarios through simulations.
- In this way, a comprehensive vision of the present situation and what-if scenarios will be obtained.

# Detection of weak points of defense plans in the pan-European grid

- A first survey for TSOs was developed, covering different topics that are relevant to iTesla objectives (Risk and Security analysis, tools, monitoring, coordination, etc.).
- Made of 106 questions, only 5 of them were related to defense plans and restoration.
- Due to this lack of data, it wasn't possible to perform a reliable analysis. This fact motivated the creation of a new specific survey, and the visits to TSOs' premises that followed.

# Detection of weak points of defense plans in the pan-European grid

TSO	Country	Survey	Visit
ELIA	Belgium	<input checked="" type="checkbox"/>	<input checked="" type="checkbox"/>
IPTO	Greece	<input checked="" type="checkbox"/>	
National Grid	UK	<input checked="" type="checkbox"/>	<input checked="" type="checkbox"/>
Statnett	Norway	<input checked="" type="checkbox"/>	
REN	Portugal	<input checked="" type="checkbox"/>	<input checked="" type="checkbox"/>
RTE	France	<input checked="" type="checkbox"/>	<input checked="" type="checkbox"/>

# Detection of weak points of defense plans in the pan-European grid

Relevant questions on the survey are related to:

- **Special Protection Systems (SPS)**
  - Type
  - Triggering
  - Instabilities the SPS aims to cure/mitigate
- **Coordination:**
  - Defense plan coordination and training
  - Inter-TSOs coordination
  - TSO-DSOs
  - Shortage plans coordination
  - Power exchange



# Detection of weak points of defense plans in the pan-European grid

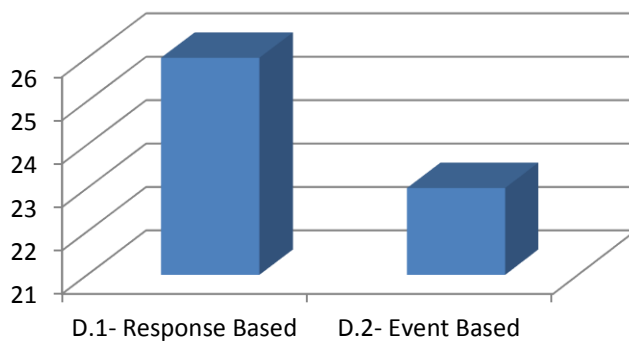
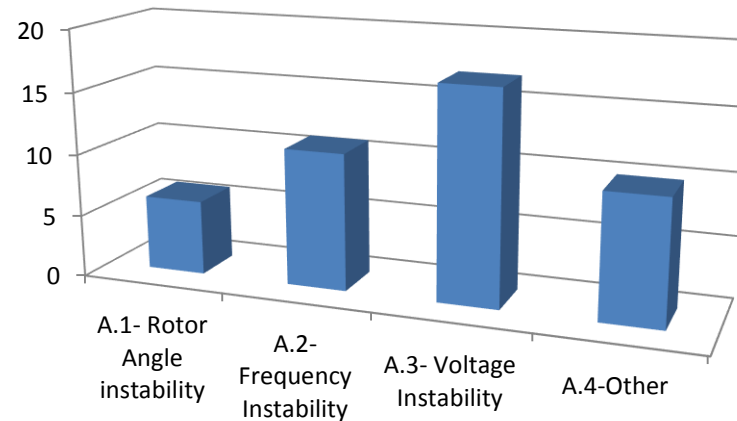

- Voltage Stability is the main concern, but there is a considerable number of “other” instabilities
- Most SPS triggering are response-based.

# Detection of weak points of defense plans in the pan-European grid

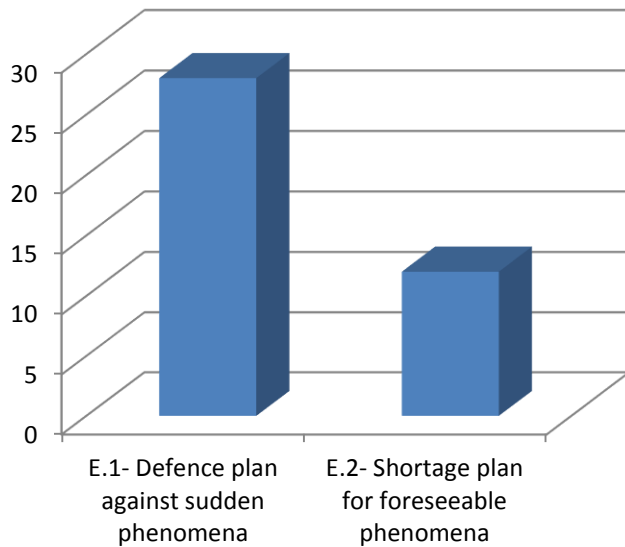

- Defense plans are mainly oriented to face sudden phenomena

# Detection of weak points of defense plans in the pan-European grid

- Varying **number of SPS** are used by different TSOs
- No TSOs are currently using **PMU's in defence plans**, but most of the TSOs have PMUs installed for detecting oscillations in the grid, and some of them are planning to utilize this information more in their defence plans in the future. Some of the TSOs use PMU information in post-mortem analysis of grid events.
- Switching of renewables according to the currently required grid protection settings can cause severe power imbalances. This calls for **coordination between TSOs and DSOs** concerning protection settings.
- Under frequency **load shedding** (UFLS) is a key element in the defence plans, but from the experience of the TSOs, the expected volume of load shedding is often not met in the case of a real event causing more steps of the UFLS to be activated. This is primarily because the distributed generation is not taken properly into account.

# Detection of weak points of defense plans in the pan-European grid

- Some TSOs use **RoCoF relays** for islanding protection of the network. RoCoF relays are also used for unit protection of conventional thermal generators and distributed embedded generators. Therefore, also the DSOs are influencing the settings. The RoCoF protection settings vary between 0.125Hz/s and 0.5Hz/s depending on the TSO.
- **Renewable energy** is used by some TSOs in the emergency frequency control and voltage control.
- **Demand side** response is only used sparsely in the emergency frequency control. Some TSOs are considering to use this option more.
- **HVDC interconnectors** are used in defence plans, but it must always be agreed in the specific situation, so the activation is manual.

# Renewables in defence plans

## Motivation

Example of disturbance on 4<sup>th</sup> November, 2006 at UCTE

Frequency Recordings after the split

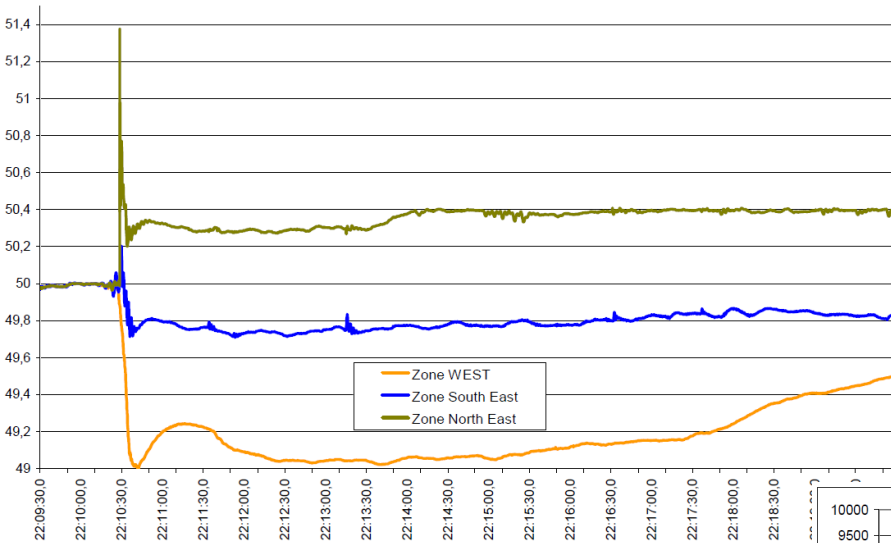

Output of wind turbines in North East Zone

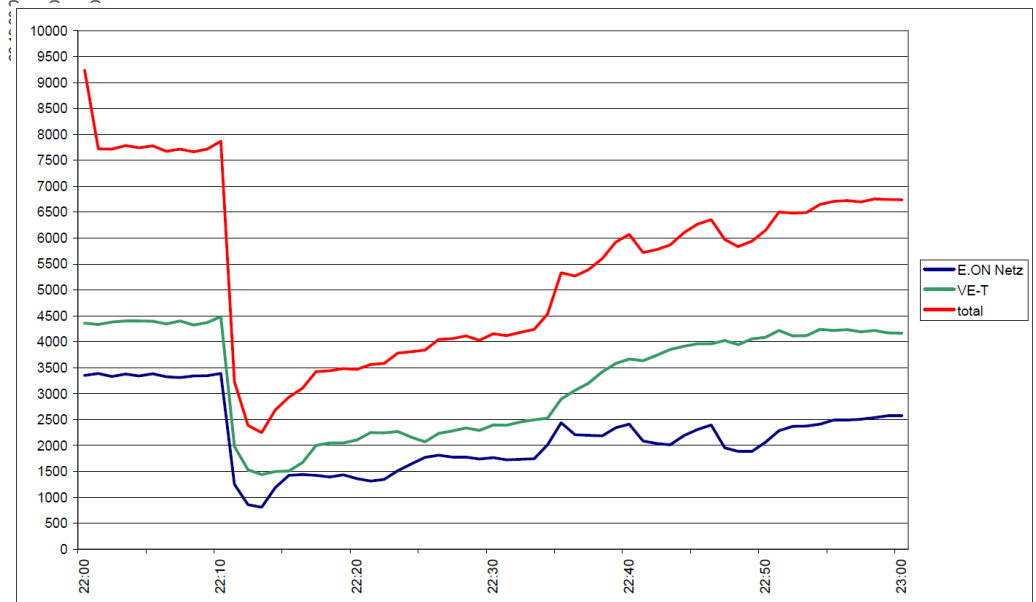

# Wind Power during Emergency

- **Overfrequency support by Wind Power Plant (WPP)**
  - Relevant option since WTs can be down-regulated
    - Fast active power control capability
  - Overfrequency protection system might need to be redesigned
    - Time delays in providing active power support by WT need to be modelled
    - Risk of tripping of ROCOF based relays of conventional generators
- **Underfrequency support by WPP**
  - Additional Control in modern WTs
    - Conventional primary control or droop control:  $P \sim \Delta f$ 
      - Only possible with WT reserves
    - Inertial control ( $P \sim df/dt$ ) or temporary primary control possible
- **Voltage support by WPP**
  - Variable speed wind turbines: converters can temporarily be overloaded to provided additional reactive power

# Pan-European coordination

- The transition to:
  - liberalized European electricity market
  - higher penetration of renewablesincrease the international flows and loading of the power system  
→ The system is operated closer to its limits
- At the same time: more controllable devices are (or will be) installed in the European Continental Power System (HVDC, PST,...)
- Survey results coordinated control actions:
  - Up till now PFCs (power factor correctors) only used for changing the transfer capacity for spot markets (day ahead and intra day)
  - Some TSO's have reduction schemes on the HVDC connectors
  - In real time only bilateral operation agreements (coordination between two TSO's)

# Pan-European coordination

- Analysis is made on a small test system consisting of 4 zones
- Through coordination: a larger power transfer is possible to zone 4
- Also economic impact
- More info: De Boeck S., Van Hertem D. 2013. [Coordination of Multiple HVDC Links in Power Systems during Alert and Emergency Situations](#). In *IEEE Powertech*. Grenoble, 16 - 20 June 2013

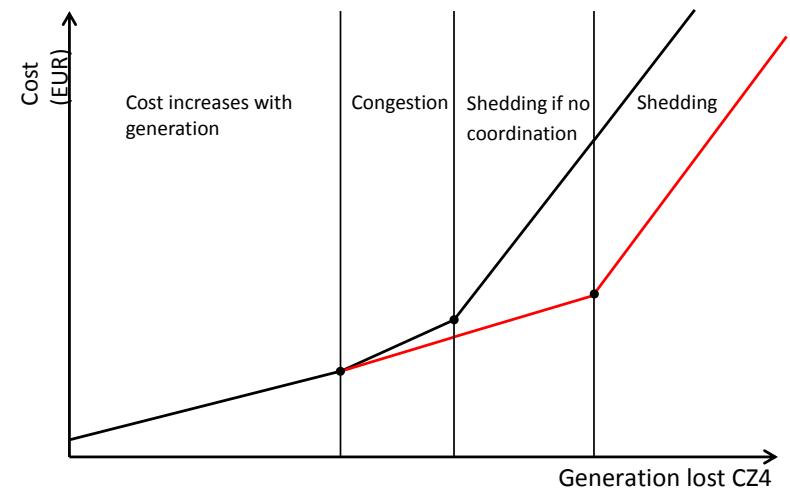
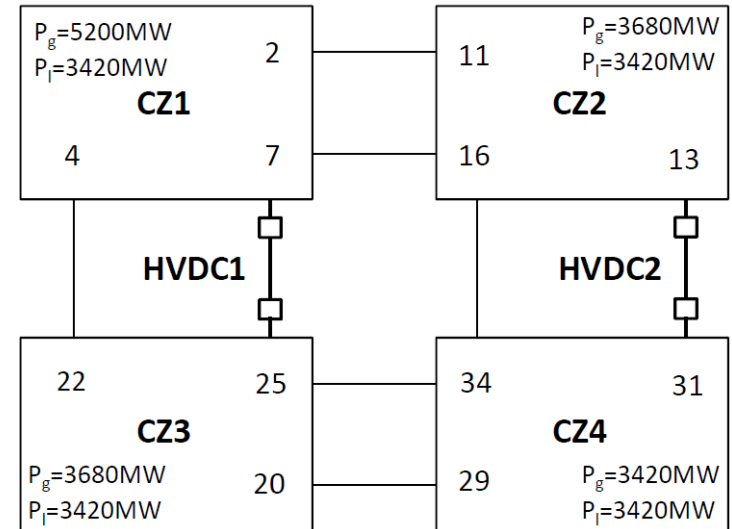



# PMUs in Defence Plans

- PMUs provide high accuracy time-synchronized information of the power grid variables in different areas of the system, and can thus be used to observe oscillations, voltage levels, and frequencies at different areas
- The main goal of the WP6.4 (PMUs in defence plans) is to make advances in detection and prevention of instabilities using PMU information
  - The focus is on voltage stability but other types of instability phenomena are also considered
- Survey results:
  - The TSOs do not use PMU information in defence plans or in restoration processes at this stage
  - Most of the TSOs have PMUs installed for detecting oscillations in the grid, and some are planning to utilize this information more in the defence plans in the future
  - Some of the TSOs use PMU information in post-mortem analysis of grid events

# PMUs in Defence Plans

- Recent developments:
  - The implementation of the test system (Nordic 32 system) for real-time simulation is completed
    - The test system is modeled for voltage stability and security assessment by following IEEE Task Force Report
    - Some modifications have been applied due to components' unavailability provided in the Simulink library
    - The difference of the test system between the one in the Task Force Report and the one for real-time simulation is documented
    - This document will be used in order to tune the test system modeled for off-line simulation (Eurostag)
  - A methodology for out-of-step relay tuning has been developed
    - The methodology has been successfully applied by hand on a simple case
    - A prototype was developed to automate the tuning process
      - The prototype was not entirely successful, as the objective function was very discontinuous
      - Therefore, the optimisation problem has been reformulated in order to smoothen the objective function
      - The prototype will now be adjusted
    - Two ways have been identified to include PMU information:
      - Direct calculation of the voltage at the electrical centre
      - Monitoring of rotor angle dynamics

# Distributed energy resources

Investigate novel defence plans based on **DER to support system security**.

There are **3 tasks** led by Imperial, KUL and DTU

- DSR-SFC (Imperial): study the importance and assess the **value** of defence plans that recognise the contribution of **DSR-SFC** to enhance frequency control regulation in future power systems
- DG online estimation (KUL): design novel **load shedding** schemes that use information from **proper online estimation of distributed generation** to minimise shedding of DER
- DG support to system stability (DTU): analysis of the impacts (including contributions) of **embedded wind** power on **system frequency and voltage control**.

# Demand side response system frequency control (DSR-SFC)

## Key tasks

1. Dynamic model design of domestic thermostatic loads (refrigeration)
2. Model analysis of collective responses from thermostatic loads to frequency events
3. Design of a control strategy to manage DSR-SFC appliances that provide system frequency control

## Key findings

- Our initial models have demonstrated the potential of distributed domestic DSR-SFC appliances to enhance system inertial response.
- Recent survey demonstrated interest from EU TSOs in integrating temperature control devices for frequency control purposes

Frequency Nadir: High Wind

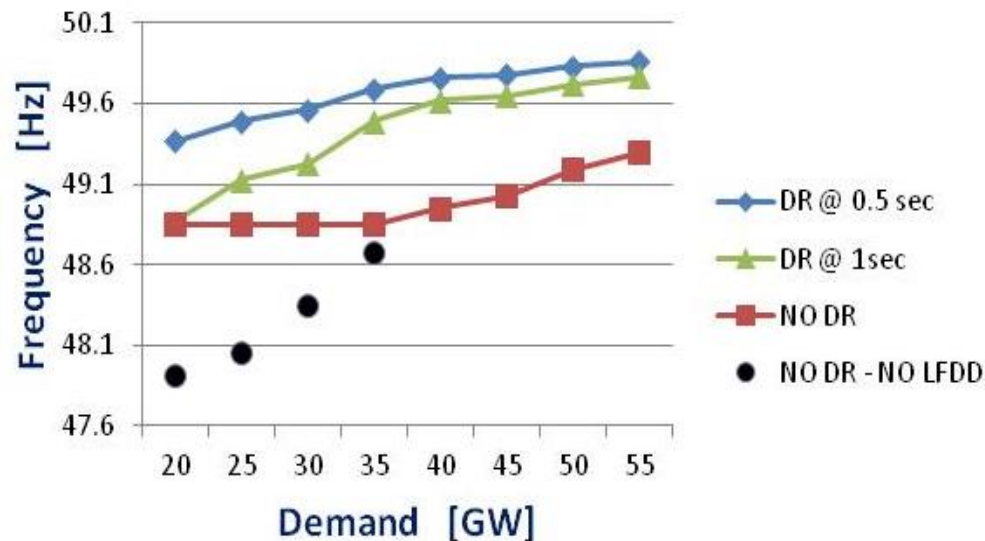

## Future work

- Improve control algorithm
- Include commercial refrigeration (apart from domestic heating systems)
- Assess the effects of DSR-SFC on system's ability to absorb renewable generation
- Analyse compliance of DSR-SFC with TSO's security standards

- Define a Coordination methodology among TSO's to solve efficiently blackout situations at a Pan-European level.
  - Limited scope of each TSO vision of the network.
  - A coordinator role is required to optimize the restoration strategy.
  - The coordinator will define global strategies ensuring that restoration plans guarantee global security of the network.
- AIA and Tractebel after defining a spec document for connectivity and data workflow integration (authored by both companies' teams) are working together to develop the programming and testing in order to have a tool and framework to simulate real time FIELD-SCADA-EMS and analyze and test Hierarchical Coordinated Restoration based on their tools
  - AGORA (AIA) tool for automatic restoration and other EMS functions
  - FAST DTS(Tractebel) tool providing field simulation, dynamic analysis.

- Proposed technical platform
  - 2 Regions and a Coordinator.
  - Single network model shared between all systems.
  - A single simulator. Tractebel FAST DTS.
  - 3 AGORA installations: one for each Region, one for the Coordinator.

# Methodology for Hierarchical Coordinated Restoration Testing framework

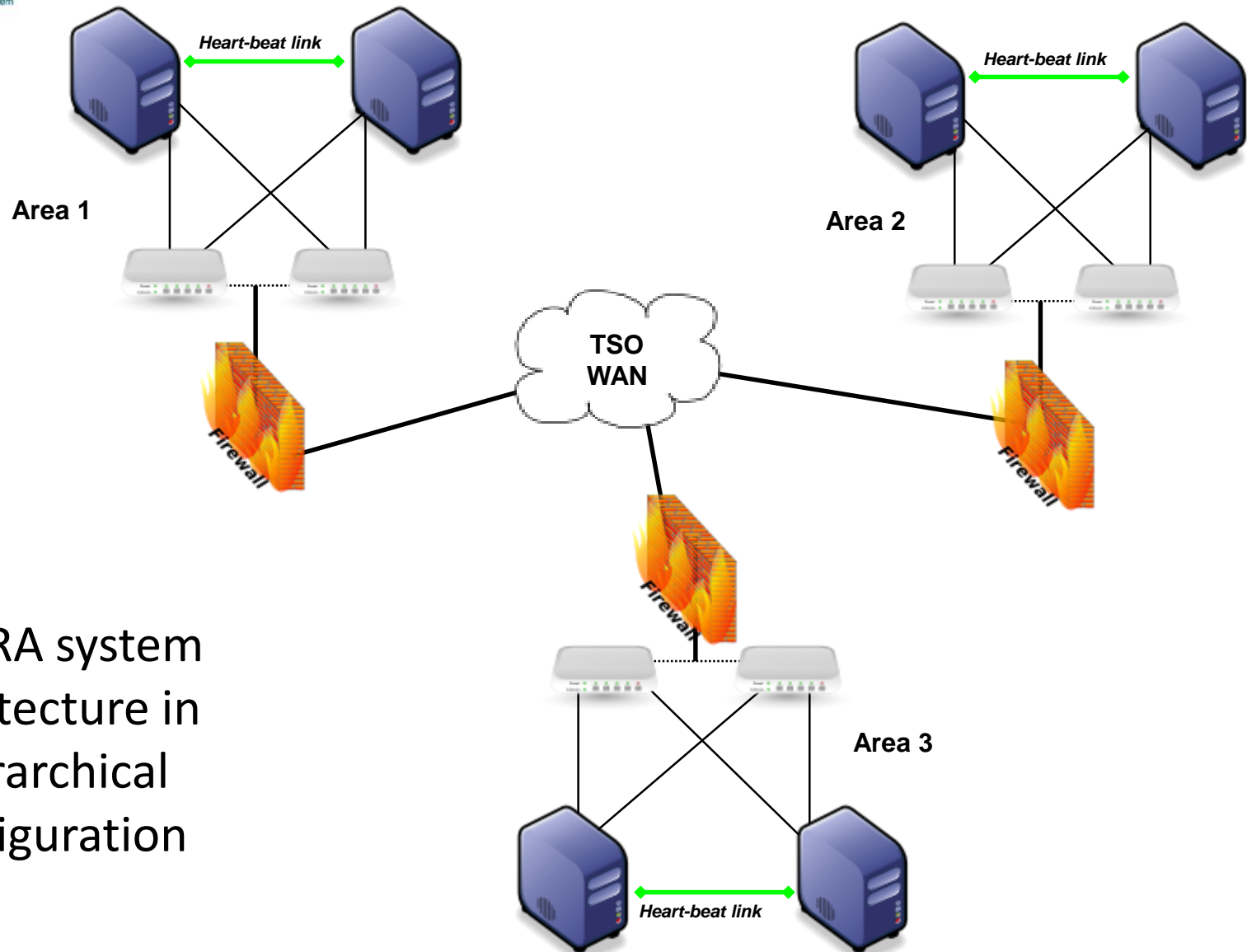

AGORA system  
architecture in  
hierarchical  
configuration

## Communications between AGORA and FAST DTS simulator

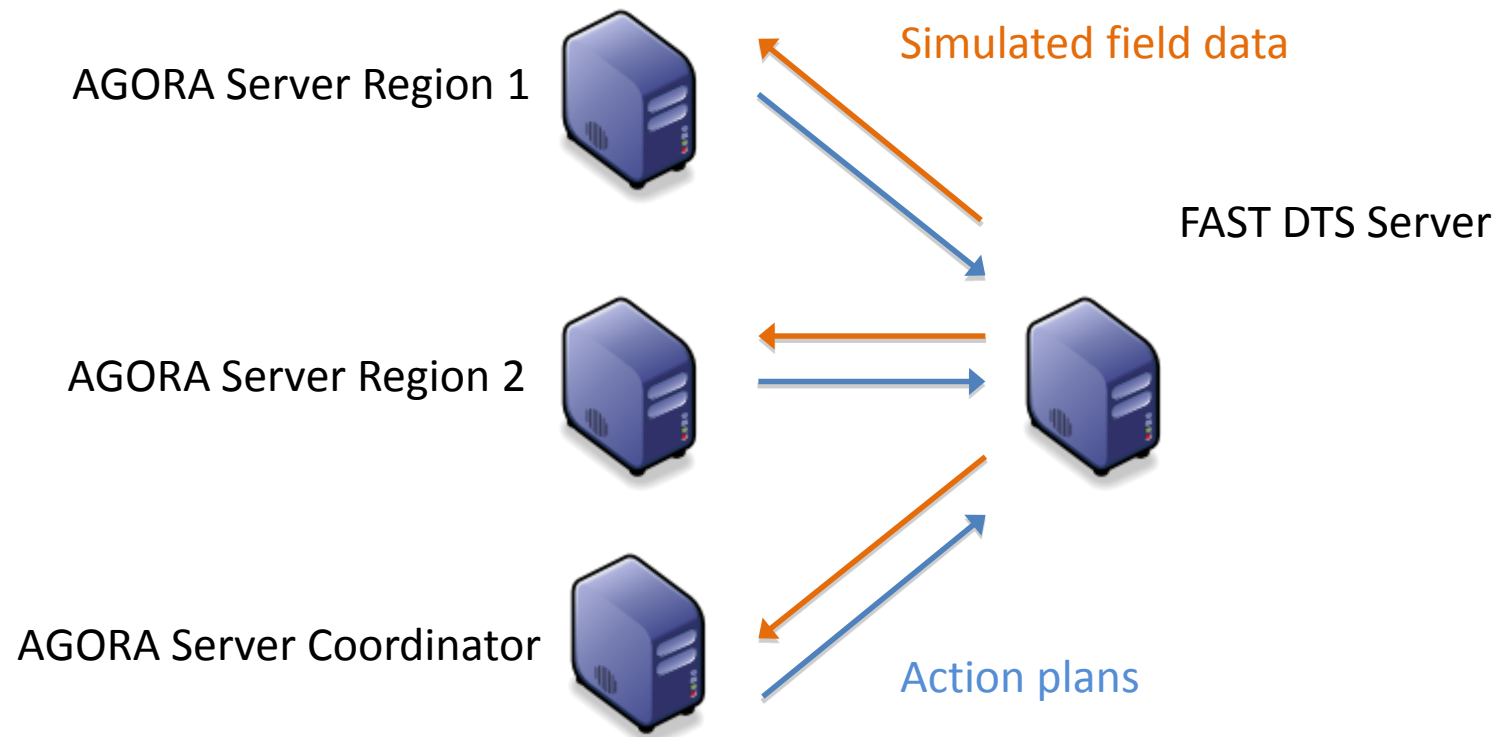



# Use of renewables in restoration

- Extensive testing in a typical VHV network
  - (380 kV, 22 buses, 4 conventional generators using synchronous machines, 2 hydro units, 2 thermal-fossil steam units and on-shore and off-shore WF)
- Both on-shore and offshore WF were modeled with the capability of participating in primary frequency control services, contributing to mainland primary frequency regulation.

# Use of renewables in restoration

- HVDC connected offshore WF
  - frequency changes in the mainland grid are proportionally converted into DC voltage changes, through a droop control approach implemented at the onshore HVDC station
  - these DC voltage changes are converted by the offshore HVDC station into frequency changes, exploiting another droop control approach
  - Regarding the provision of reactive power / voltage control, the HVDC-VSC is assumed to be capable to provide such functionality, behaving in a similar way to a STATCOM

# Thank you

- Questions?
  - Workplan defense / restoration
    - Defense plans
      - » Weak points in existing plans (AIA)
      - » Use of renewable generation plants (DTU)
      - » Pan-European coordination (KU Leuven)
      - » Use of PMUs (Statnett / KTH)
      - » Use of distributed energy resources (Imperial Col.)
    - Restoration
      - » Coordinated restoration (AIA)
      - » Use of renewable generation plants (INESC)