



Inter-RMO Key Comparison EUROMET.L-K5.2004: Calibration of a step gauge Final report

Prieto, Emilio; Brown, Nicholas; Lassila, Antti; Lewis, Andrew; Matus, Michael; Vailleau, Georges; De Chiffre, Leonardo; Kotte, Gerard W J L; Frennberg, Mikael; McQuoid, Howard

Total number of authors:
19

Published in:
Metrologia

Link to article, DOI:
[10.1088/0026-1394/49/1A/04008](https://doi.org/10.1088/0026-1394/49/1A/04008)

Publication date:
2012

Document Version
Publisher's PDF, also known as Version of record

[Link back to DTU Orbit](#)

Citation (APA):

Prieto, E., Brown, N., Lassila, A., Lewis, A., Matus, M., Vailleau, G., De Chiffre, L., Kotte, G. W. J. L., Frennberg, M., McQuoid, H., Zelený, V., Ramotowski, Z., Bánréti, E., Duta, A., Picotto, G. B., Doytchinov, K., Valente de Oliveira, J. C., Alonso, M. V., & Chekirda, K. (2012). Inter-RMO Key Comparison EUROMET.L-K5.2004: Calibration of a step gauge: Final report. *Metrologia*, 49(1A), 04008. <https://doi.org/10.1088/0026-1394/49/1A/04008>

General rights

Copyright and moral rights for the publications made accessible in the public portal are retained by the authors and/or other copyright owners and it is a condition of accessing publications that users recognise and abide by the legal requirements associated with these rights.

- Users may download and print one copy of any publication from the public portal for the purpose of private study or research.
- You may not further distribute the material or use it for any profit-making activity or commercial gain
- You may freely distribute the URL identifying the publication in the public portal

If you believe that this document breaches copyright please contact us providing details, and we will remove access to the work immediately and investigate your claim.

Inter-RMO Key Comparison EUROMET.L-K5.2004

Calibration of a Step Gauge

Final Report



Centro Español de Metrología

Tres Cantos, October 2011

E. Prieto

Content

1	INTRODUCTION	5
2	ORGANIZATION	5
2.1	FORM OF COMPARISON	5
2.2	PARTICIPANTS	6
2.3	PARTICIPANTS' DETAILS	6
2.4	SCHEDULE	9
2.5	HANDLING OF THE ARTEFACT	10
2.6	TRANSPORT OF THE ARTEFACT	10
3	DESCRIPTION OF THE STANDARD	11
3.1	ARTEFACT	11
3.2	DAMAGES	11
4	MEASUREMENT INSTRUCTIONS	13
4.1	TRACEABILITY	13
4.2	MEASURANDS	13
4.3	INSPECTION OF THE ARTEFACT	13
4.4	ALIGNMENT	14
4.5	MEASUREMENT UNCERTAINTY	14
5	STABILITY AND CONDITION OF THE STEP GAUGE	14
6	MEASUREMENT RESULTS, AS REPORTED BY PARTICIPANTS	19
7	MEASUREMENT UNCERTAINTIES	20
8	ANALYSIS OF THE REPORTED RESULTS, KCRVS AND UNCERTAINTIES	22
8.1	INITIAL CONSIDERATIONS	22
9	MAIN GROUP: ALL PARTICIPANTS EXCEPT CENAM AND CEM4	37
9.1	WEIGHTING FACTORS AND REFERENCE VALUE	39
9.2	UNCERTAINTIES:	39
9.3	ANALYSIS USING E_N VALUES	40
9.4	BIRGE RATIO TEST	41
9.5	SUMMARY OF RESULTS	43
10	SECOND GROUP: CENAM-CEM4	55
10.1	SUMMARY OF RESULTS CENAM-CEM4	57
11	LINKING THE TWO-LAB GROUP TO THE MAIN ONE	65
12	FINAL SUMMARY OF RESULTS	66
13	CONCLUSIONS	84
14	ANNEX A: MEASUREMENT METHODS AND INSTRUMENTS USED BY THE PARTICIPANTS	85

1 Introduction

The metrological equivalence of national measurement standards is determined by a set of key comparisons chosen and organised by the Consultative Committees of the CIPM working closely with the Regional Metrology Organizations (RMOs).

At its meeting in September 1997, the Consultative Committee for the Definition of the Metre (CCDM, today called Consultative Committee for Length, CCL) identified several key comparisons in the field of dimensional metrology. One of these comparisons, named CCL-K5, consists in step gauge measurement.

At its meeting in 2003, the EUROMET¹ Technical Committee on Length decided that a new key comparison on step gauge measurements shall be carried out, starting in 2004, with the Centro Español de Metrología (CEM) acting as the pilot laboratory.

Before that meeting, in September 2003, CCL 11 decided to introduce some changes in future Key Comparisons by having interregional participation organized through the Regional Technical Committees for Length (RTCLs) and the WGDM, so leaving the regions in charge of their comparisons but bringing the CCL/WGDM into the loop to be able to monitor and negotiate any difficulties. So, participants should look at other regional KC with a view to finding a) a better time to do the comparison, b) a better uncertainty range or c) a more appropriate technique or method.

2 Organization

The technical protocol for this new KC was drawn up by the Centro Español de Metrología (CEM), based on the previous one drawn in 1999 by the Physikalisch-Technische Bundesanstalt (PTB), Germany, for the first CCL-K5 Key Comparison, but having in mind that this is a new type of interregional comparison, with participants from different regions and a more complicated process linked to the transport of the artefact and customs formalities. Technical Procedure follows also the guidelines established by the BIPM².

2.1 Form of comparison

The comparison was established in a mixed form, both 'circular' and 'star-shaped'. The artefacts were circulated within a region then returned to the pilot laboratory before circulation in the next region. Because of time constraints, it was not possible to arrange for a 'star-shaped' circulation within each region.

CEM acted as the pilot laboratory and NMIA as co-pilot. Although laboratories should communicate all results directly to the pilot laboratory as soon as possible and, in any case, within 6 weeks of completion of the measurements, there were particular bigger delays in communicating such data.

The calibration suitability of the artefact was assessed by measurements prior to the start of the circulation of the artefact.

Each laboratory received the artefact in turn, according to the pre-agreed timetable, having one month for calibration and transportation. Such pre-agreed timetable was slightly modified along the comparison as result of several laboratories asking for re-measuring the step or because changing the measuring order. Intermediate measurements of the step and a final set of measurements at the end of the comparison were made by the pilot laboratory.

¹ Since 1 July 2007, EURAMET e.V., a registered association of public utility under German law, is the successor of EUROMET. EURAMET e.V. is the European Association of National Metrology Institutes and the Regional Metrology Organisation (RMO) of Europe.

² T.J. Quinn, Guidelines for key comparisons carried out by Consultative Committees, BIPM, Paris

If for some reasons, the measurement facility was not ready or customs clearance took too much time in a country, the laboratory had to contact the pilot and co-pilot laboratories immediately and – according to the arrangement made - eventually to send the standard directly to the next participant before finishing the measurements or even without doing any measurements. If possible the laboratory will be sent the artefact at the end of the comparison.

2.2 Participants

The list of participants was taken from the proposed EUROMET Project Form, after circulating it among EUROMET members, and from written contacts maintained with other regions through WGDM members.

The participating laboratories should be able to calibrate step-gauges with their best uncertainty less than 1 μm . All participants must be able to demonstrate independent traceability to the realization of the metre.

There was an additional requirement to measure the artefacts at a temperature sufficiently close to 20 °C that the uncertainty in the measured expansion coefficient would not dominate the overall measurement uncertainty.

By their declared intention to participate in this key comparison, the laboratories accepted the general instructions and the technical protocol and committed themselves to follow the procedures strictly. Once the protocol and list of participants was agreed, no change to the protocol or list of participants could be made without prior agreement of all participants.

2.3 Participants' details

EURAMET

Country	Laboratory	Contact Person	Address	Tel. Fax e-mail:
France	BNM-LNE (now LNE)	Georges Vaillieu	Laboratoire National d'Essais 1 rue Gaston Boissier FR – 75015 Paris France	+33 1 40 43 38 24 +33 1 40 43 37 37 georges.vaillieu@lne.fr
Austria	BEV	Michael Matus	Bundesamt für Eich- und Vermessungswesen Gruppe Eichwesen Arltgasse 35 AT – 1160 Wien Austria	+43 1 49 110 540 +43 1 49 20 875 m.matus@bev.gv.at
Denmark	DANIAMet-CGM	Leonardo De Chiffre	DANIAMet-CGM Primary Lab. For Dimensional Metrology CGM, Bld. 425 Technical University of Denmark DK-2800 Lyngby Denmark	+45 4525 4760 +45 4593 0190 ldc@ipl.dtu.dk
Netherlands	NMi-VSL (now VSL)	Gerard W.J.L. Kotte	Van Swinden Laboratorium B. V. Schoemakerstraat 97 P.O. Box 654 NL – 2600 AR Delft The Netherlands	+31 15 269 16 01 +31 15 261 29 71 gkotte@nmi.nl
Finland	MIKES	Antti Lassila	MIKES - Centre for Metrology and Accreditation P.O. Box 239 FI – 00181 Helsinki Finland	+358 9 6167 521 +358 9 6167 467 antti.lassila@mikes.fi

Sweden	SP	Mikael Frennberg	Swedish National Testing and Research Institute P.O. Box 857 SE – 501 15 Boras Sweden	+46 33 16 54 86 +46 33 10 69 73 mikael.frennberg@sp.se
United Kingdom	NPL	Andrew Lewis	National Physical Laboratory Queens Road Teddington Middlesex UK – TW11 0LW United Kingdom	+44 20 8943 6124 +44 20 8614 0533 andrew.lewis@npl.co.uk
Ireland	NML	Howard McQuoid	National Metrology Laboratory Enterprise Ireland Campus Glasnevin IE – Dublin 9 Ireland	+353 1 808 2657 +353 1 808 2026 howard.mcquoid@enterprise-ireland.com
Czech Republic	CMI	Vít Zelený	Czech Metrology Institute Laboratories of Fundamental Metrology V Botanice 4 CZ – 150 72 Praha 5 Czech Republic	+420 257 288 387 +420 257 328 077 vzeleny@cmi.cz
Poland	GUM	Zbigniew Ramotowski	Central Office of Measures P.O. Box 10 Ul. Elektoralna 2 PL – 00-950 Warszawa Poland	+48 22 620 54 38 +48 22 620 83 78 length@gum.gov.pl
Hungary	OMH (now MKEH)	Edit Bánréti	National Office of Measures 1124 Budapest, Németsvölgyi út 37-39 H – 1535 Budapest, Pf. 919 Hungary	+36 1 458 59 97 +36 1 458 59 27 e.banreti@mkeh.hu
Romania	INM	Alexandru Duta	National Institute of Metrology 11, Sos. Vitan-Bârzesti RO – 75669 Bucharest 4 Romania	+40 21 334 55 20 +40 21 334 55 33 duta@inm.ro
Italy	IMGC (now INRIM)	Gian Bartolo Picotto	Istituto Nazionale di Ricerca Metrologica (INRIM) Strada delle Cacce, 73 10135 – Torino Italy	+39 011 3919 969/973 +39 011 3919 959 g.picotto@inrim.it
Portugal	IPQ-LCM	Fernanda Saraiva	Instituto Português da Qualidade (1) Rua António Gaió, 2 PT-2829-513 Caparica Portugal	+35 121 2948 160 +35 121 2648 188 fsaraiva@mail.ipq.pt

(1) IPQ was added in June 05, after agreement of participants but finally resigned to measure in April 07 by technical reasons.

Other RMOs:**SIM:**

Canada	NRC	Kostadin Doytchinov	Institute for National Measurement Standards National Research Council Canada 1200 Montreal Rd. M-36 Ottawa, K1A 0R6 Canada	Tel. +1-613-991-0265 Fax +1-613-952-1394 e-mail: kostadin.doytchinov@nrc.ca
Brazil	INMETRO	Jose Carlos Valente de Oliveira	National Institute of Metrology, Standardization and Industrial Quality Av. N. Sra. das Graças, 50 Vila Operária - Xerém - Duque de Caxias - R. J. CEP: 25250-020 - Brazil	Tel.: 005521-26799036 Fax: 005521-26791505 email: icoliveira@inmetro.gov.br
Mexico	CENAM	Miguel Viliesid Alonso	Centro Nacional de Metrología (2) Metrología Dimensional Apartado Postal 1-100 Centro 76000 Querétaro Mexico	Tel. +52 42 11 0574 Fax +52 42 11 0577 e-mail: mviliesi@cenam.mx

(2) CENAM was added in December 06, after agreement of participants, to measure at the end of the comparison.

SADCMET:

South Africa	CSIR-NML	Oelof Kruger	National Metrology Laboratory (3) P.O. Box 395 ZA – 0001 Pretoria South Africa	+27 12 841 3005 +27 12 841 2131 oakruger@csir.co.za
--------------	-----------------	--------------	--	--

(3) CSIR-NML resigned to measure by technical reasons.

APMP:

Australia	NMIA	Nicholas Brown	National Measurement Institute Bradfield Road, West Lindfield PO Box 218 Lindfield NSW 2070 Australia	02 8467 3509 02 8467 3655 nick.brown@measurement.gov.au
-----------	-------------	----------------	---	--

COOMET:

Russia	VNIIM	Konstantin Chekirda	All-Russian Institute for Metrology 19 Moscovsky prosp. RU – 198005 St. Petersburg Russia	+7 095 535 0891 +7 095 535 73 86 k.v.chekirda@vniim.ru
--------	--------------	---------------------	--	---

Coordinators:

Spain	CEM	Emilio Prieto	Centro Español de Metrología C/del Alfar, 2 28760 Tres Cantos Spain	Tel. +34 91 8074 716 Fax +34 91 8074 807 email: eprieto@cem.mityc.es
Australia	NMIA	Nicholas Brown	National Measurement Institute Bradfield Road, West Lindfield PO Box 218 Lindfield NSW 2070 Australia	02 8467 3509 02 8467 3655 nick.brown@measurement.gov.au

2.4 Schedule

Comparison lasted since December 2004 to December 2007. Although mostly according to the schedule, there were some shifts and delays as indicated in the following table:

LNE and NPL asked for re-measuring, GUM and INMETRO delayed their participation for some months, CSIR-NML and IPQ withdrew to participate. All re-measuring and delays were agreed by the rest of participants, by e-mail.

Region	NMI	1 st measurement	2 nd measurement
EURAMET	CEM	Dec 04 – Jan 05	
	BEV	Feb 05	
	NML	March 05	
	LNE	Apr 05	Nov 05
	OMH	May 05	
	SP	Jun 05	
	CEM	July 05	
	NPL	Aug 05	March 06
	CGM	Sept 05	
	CMI	Oct 05	
	GUM	(delayed)	
	INM	Dec 05 – Jan 06	
	INRIM	Feb 06	
	CEM	March-April 06	
SIM	NRC	Jun 06	
	INMETRO	(delayed)	
SADCMET	CSIR-NML	(withdrawn)	
APMP	NMIA	Aug 06	
COOMET	VNIIM	Sep - Oct 06	
EURAMET	MIKES	Nov 06	
	VSL	Dec 06	
	IPQ	(withdrawn)	
	GUM	Feb 07	
SIM	INMETRO	Apr – May 07	
	CEM	(passing through)	
SIM	CENAM	Sep 07	
	CEM	Dec 07	

Table 1 – Timetable of the comparison.

2.5 Handling of the artefact

The artefact should be examined immediately upon receipt. The condition of the artefact should be noted and communicated to the pilot laboratory.

The artefact should only be handled by authorised persons and stored in such a way as to prevent damage.

The artefact should be examined before despatch and any change in condition during the measurement at each laboratory should be communicated to the pilot laboratory.

Laboratories should inform the pilot laboratory and the next laboratory via fax or e-mail when the artefact was about to be sent to the next recipient.

Before and after the measurements, the artefact must be cleaned. Participants should ensure that the content of the package was complete before shipment. Always should be used the original packaging.

2.6 Transport of the artefact

It was of utmost importance that the artefact was transported in a manner in which it was not be lost, damaged or handled by un-authorised persons.

Packaging for the artefact was made suitably robust to protect the artefacts from being deformed or damaged during transit.

Artefact should be sent via courier or Delivery Company and marked as 'Fragile' and 'Handle with care'.

For loops outside UE the artefact was accompanied by an **ATA carnet** identifying the item uniquely. Because the ATA carnet expires at a certain date, the shipping back to the pilot laboratory had to be initiated early enough. Because the delays and new participants added at the end of the loop, it was necessary CEM to manage to extend the validity of the ATA carnet.

Each participant must pay for the cost of collecting the artefact from their customs (and any customs charges) and the cost of shipping the artefact to the next participant's country. Participants also covered the costs for their own measurements, and for any damage that may have occurred to the artefact within their own country. The overall costs for the organisation and for the artefact were covered by the organising pilot laboratory, this one having no insurance for any loss or damage of the standard during transportation.

3 Description of the Standard

3.1 Artefact

The measurement artefact is a **step-gauge KOBA**, steel frame, tungsten carbide gauges, 420 mm nominal length, thermal expansion coefficient $\alpha = 11.5 \times 10^{-6} \text{ K}^{-1}$

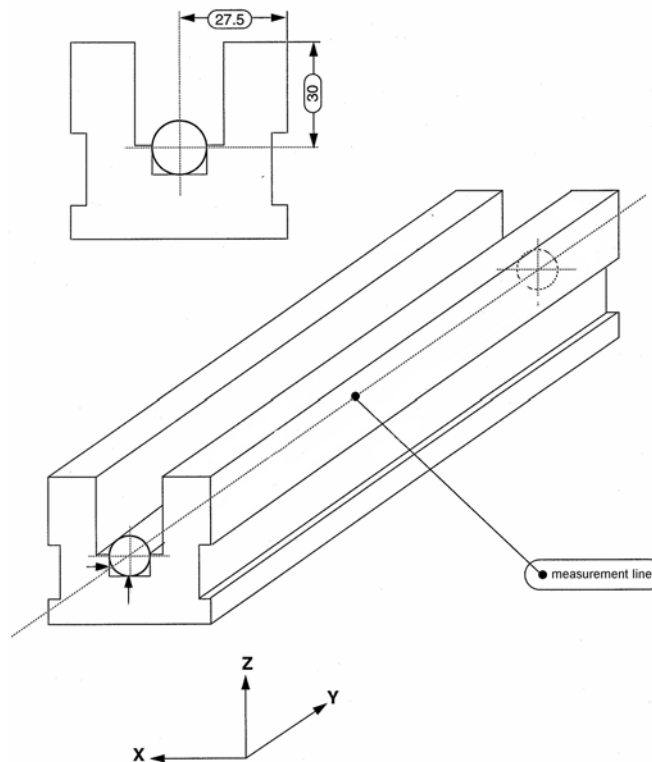

Fig. 1 - Drawing of the KOBA step-gauge

3.2 Damages

During transport some damages were observed and communicated by the participants, as follows:



Fig. 2 – Damage on the buckle of the wooden box observed and communicated by BEV.

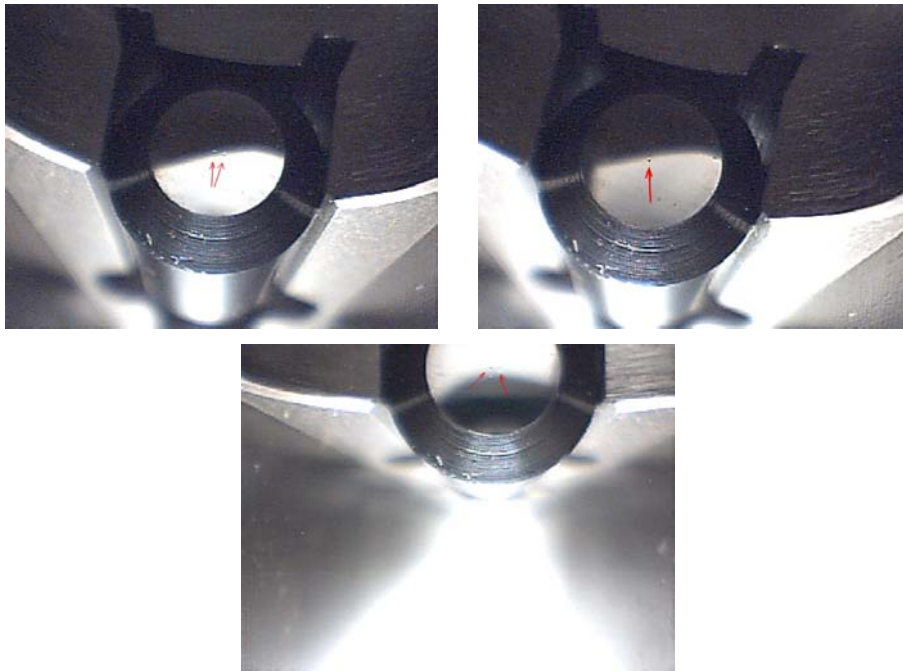

Fig. 3 - Damages on terminal gauges observed and communicated by NMI-VSL.



Fig. 4 - Some damages (scratches and points) observed and communicated by INMETRO.

Other comments received:

(OMH-Hungary): One little spot of a point on the back surface about 70 mm back from the end. There was no change in the condition after the measurements.

(BNM-LNE-France): The parallelism of measurements surfaces is considered to be of rather poor quality. For instance on step 120-140 the parallelism error is 3.0 μm on the vertical direction on the length of the face, 2 μm for the 240-260 step, ...

Due the fact that we measured the step gauge twice, **we have observed some shift on the step 260-280 mm between May and November.**

(INRIM-Italy): We noted that the outer face of the first gauge/cylinder shows a large form deviation (namely around the sampling point 0.1 mm below the centre) than the faces of the other gauges/cylinders.

4 Measurement instructions

4.1 Traceability

Length measurements should be independently traceable to the latest realisation of the metre as set out in the current "Mise en Pratique". This means that if for example the step gauge would be measured by a CMM, the traceability chain should not rely on another step-gauge, but for example on a calibration by interferometric means.

This was not possible for CGM, since the CMM axis was calibrated using a step gauge from CGM, with the same nominal specifications. The coordinator was informed before joining the comparison but the coordinator saw no problem in considering CGM as an independent participant, at the same level than any other because the following reasons:

The uncertainty claimed by CGM is comparable to others claimed by other participants and its traceability is coming from a DKD lab. not participating on this comparison. So, there are not correlation problems. Even in the case that such DKD lab. was linked to PTB, there is no correlation, because PTB is also not involved in this comparison.

Temperature measurements should be made using the International Temperature Scale of 1990 (ITS-90).

4.2 Measurands

The measurands of the step gauge are the distances of the centres of the front and back faces of the individual gauges of the step-gauge with respect to the centre of the front face of the first gauge. The measurements should be carried out as much as possible near the centres of the front faces of the gauges or along an axis passing through the centre of the measuring face No. 0 and being parallel to both the bottom face and the side alignment face.

The thermal expansion coefficient indicated for the artefact should be used by Laboratories when measuring the artefact. Laboratories should report the temperatures at which the length measurements were made. Laboratories should only measure the artefact at a temperature close to 20 °C.

4.3 Inspection of the artefact

Before calibration, the artefact must be inspected for damage to the measurement surfaces and side faces. Any scratches, rusty spots or other damages had to be documented (see 3.2).

4.4 Alignment

The alignment of the step gauge should be done by using the bottom face of the groove where the gauges are fixed and the side-walls. If a different alignment procedure was preferred by the laboratory or needed because of equipment constraints, documentation was requested together with the results. The step-gauge should be supported in the Bessel points.

The measurement results had to be appropriately corrected to the reference temperature of 20 °C using the values of the thermal expansion coefficient provided.

If for any reason a laboratory were not able to measure all positions of gauges on the step, it was still encouraged to report as much results as it could.

4.5 Measurement uncertainty

The uncertainty of measurement should be estimated according to the *ISO Guide to the Expression of Uncertainty in Measurement*.

Because for this key comparison the measurement equipment and procedure was not completely fixed it was not possible to develop a full mathematical model for the measurement uncertainty for all participants. There were broad categories that uncertainties could be grouped into, in order to produce a comparative table (Table A2 in the Appendix of the Technical Protocol does this for a measurement setup involving an interferometric-probe setup) but the participant should summarise, for the final report, their uncertainties into the broad categories listed in Table A2, leaving blank those components that didn't apply and adding additional components if necessary.

Participants should also list or highlight any influence factors preventing them from achieving their Calibration and Measurement Capabilities (CMC).

The uncertainty should be reduced to the form provided in the laboratory's Calibration and Measurement Capability (CMC) claim for this service, this normally given as a quadratic sum, expressed in short hand as $Q[a, b \cdot L]$ where a is the fixed part and b the proportional part (see CCL/WGDM/00-51c.doc "CCL-WGDM Supplement to the JCRB Instructions for Appendix C").

As the gauge cylinders may not be aligned to the measurement axis and, additionally, the faces of the gauge cylinders may be non-orthogonal to the cylinder axes, all these effects are contributions to the overall uncertainty budget.

5 Stability and condition of the step gauge

A measurement of the step gauge was realized previously, in May 2004 (Prev), before the starting of the comparison. After that, four measurements were realized by CEM in December 04 (C), July 05 (E), April 06 (M) and December 07 (F). Finally, a last measurement was made by CEM in October 08 (Post), 10 months after finished the circulation, to check for the stability of the last measurements.

The following graph shows the evolution of the position of the gauges inserted into the step where it seems that some of them (G4, G5, G6, G8, G9, G10 & G11) may have moved during the comparison, showing important deviations. This was also reported by some of the participants which requested for re-measuring the step.

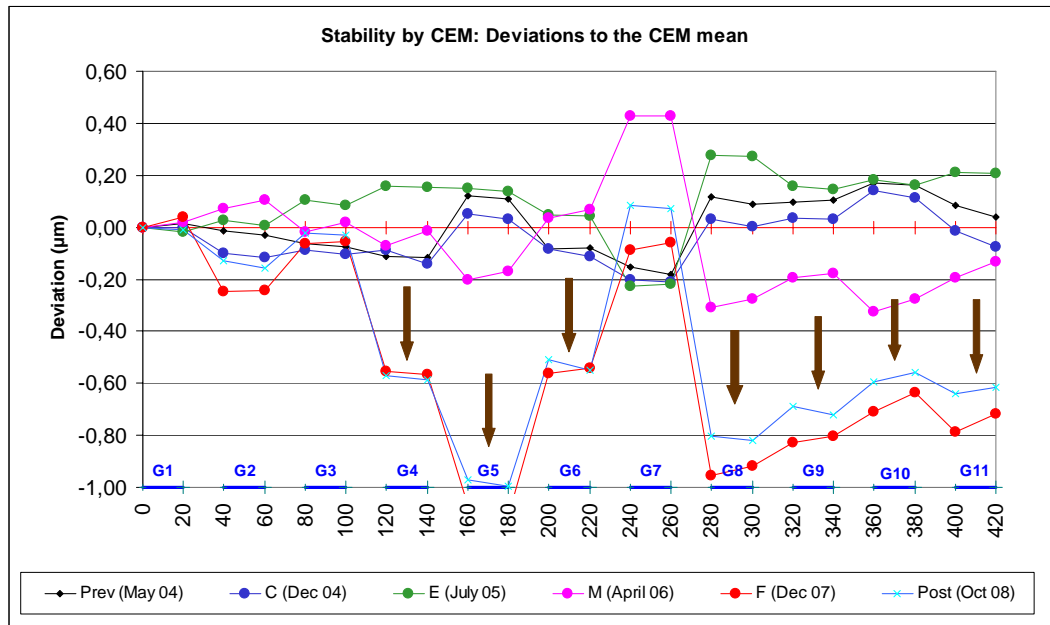
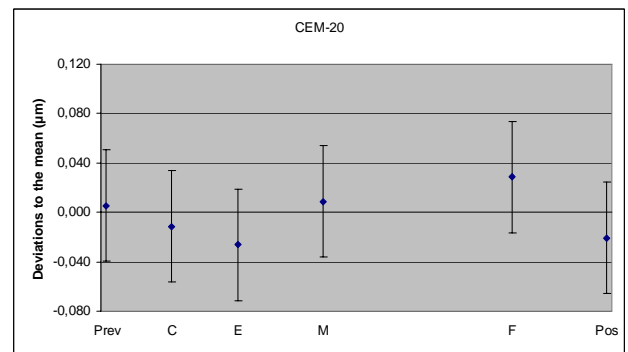

Fig. 5 – Differences between CEM calibrations of the step since May 2004 (7 months before starting the KC) until October 2008 (10 months after finished the KC).

The method of fixing the gauge on the step is crucial to avoid the shifting of gauges, when combined with temperature changes and beats during transportation. Also, a strong contact with the probe during the process of approximation to the face (see marks in Fig. 3) may cause not only a local damage but also the displacement of the gauge within his holder, in the micrometer range.

Next figures show the evolution of the gauges (face by face) along the comparison, as seen by the Pilot. Horizontal axis represents the true time scale.



Gauge 1

Fig. 6 (a)

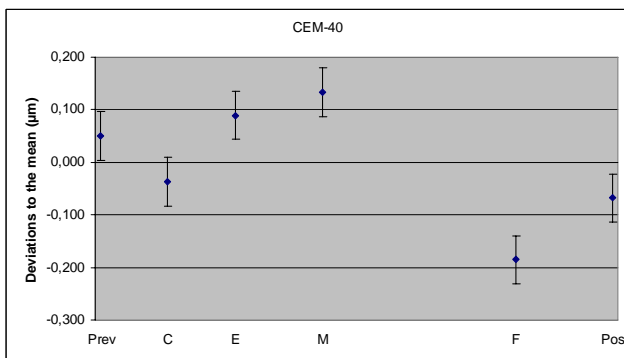

Fig. 6 (b)

Gauge 2

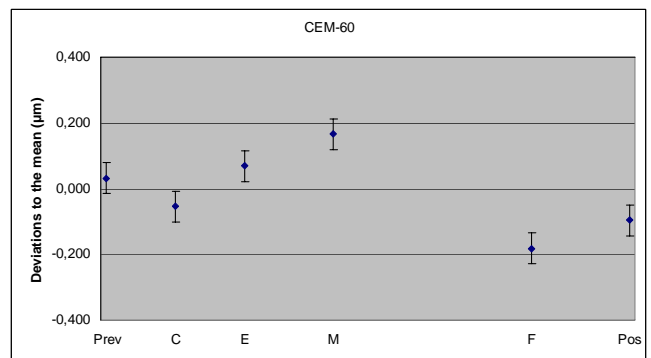

Fig. 6 (c)

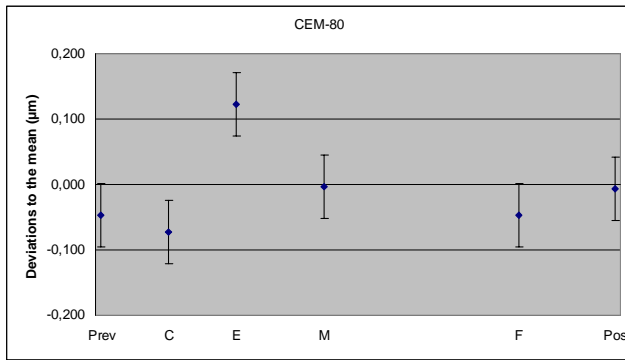

Fig. 6 (d)

Gauge 3

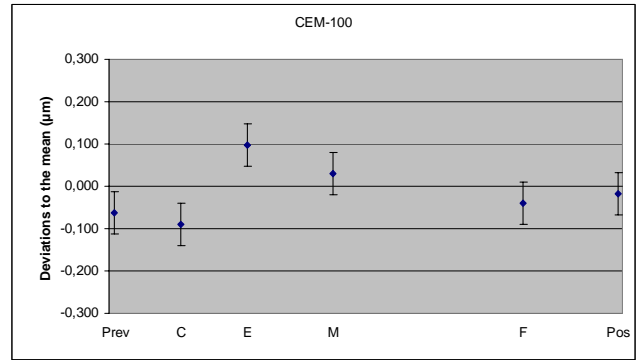

Fig. 6 (e)

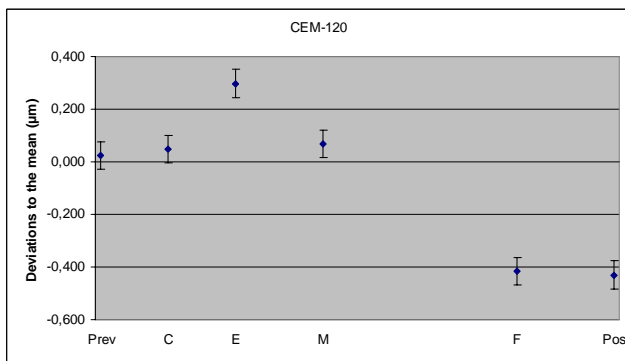

Fig. 6 (f)

Gauge 4

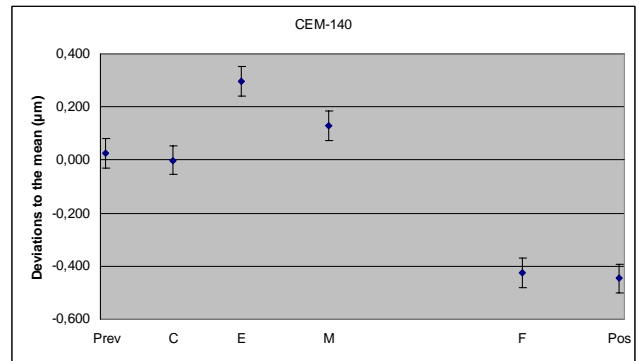

Fig. 6 (g)

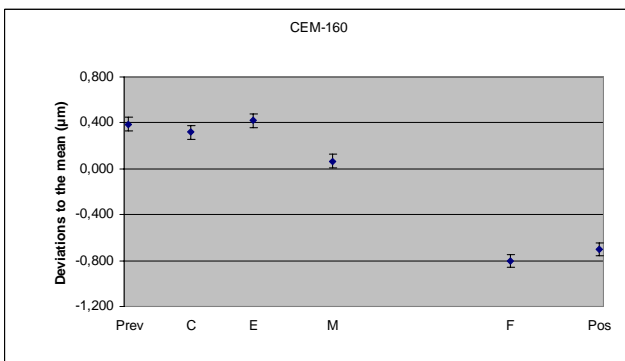

Fig. 6 (h)

Gauge 5

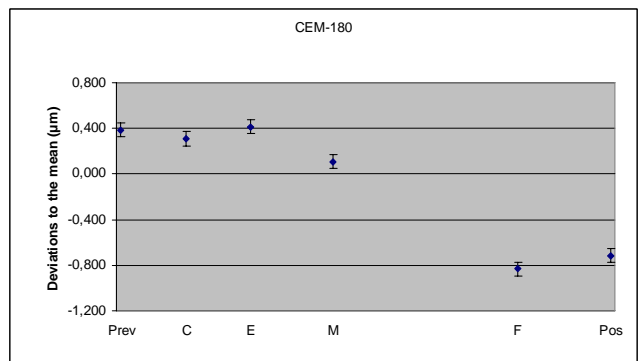

Fig. 6 (i)

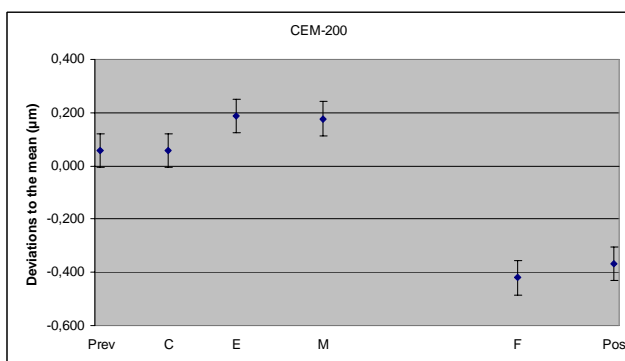

Fig. 6 (j)

Gauge 6

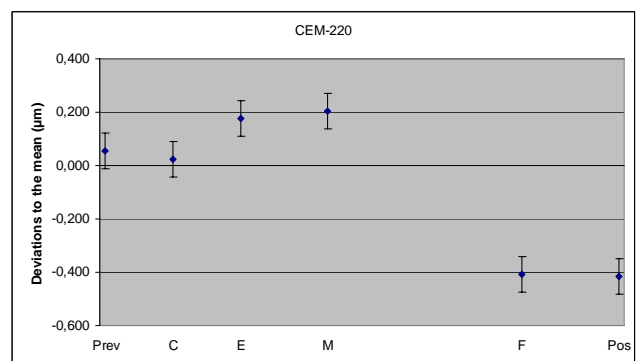

Fig. 6 (k)

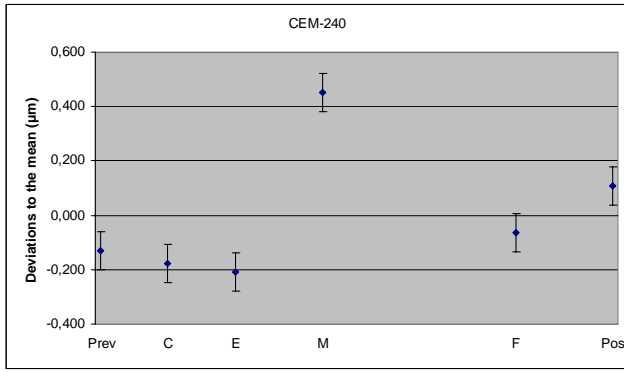

Fig. 6 (l)

Gauge 7

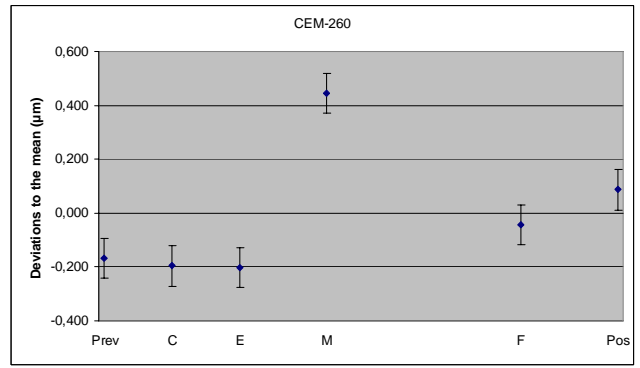

Fig. 6 (m)

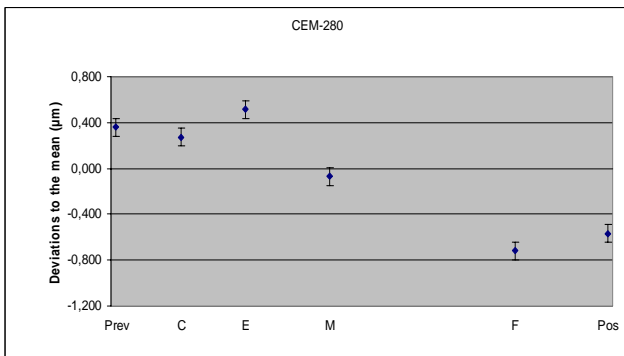

Fig. 6 (n)

Gauge 8

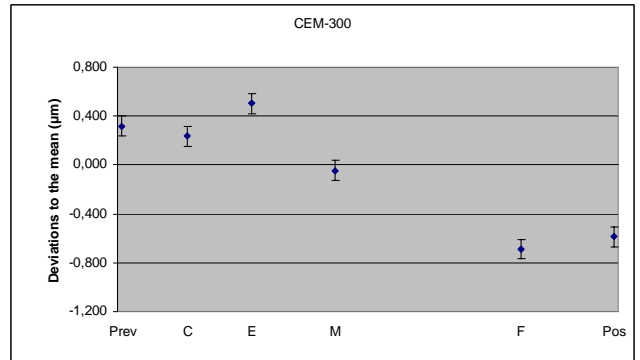

Fig. 6 (o)

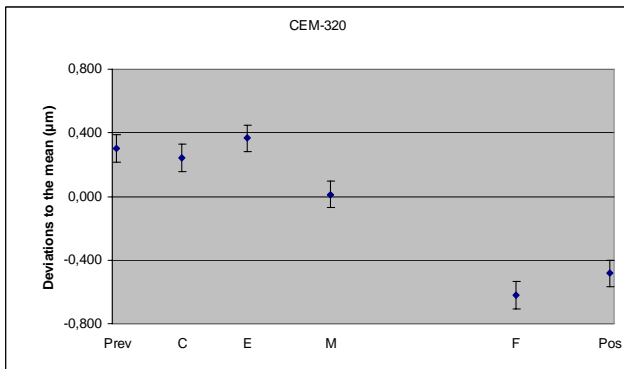

Fig. 6 (p)

Gauge 9

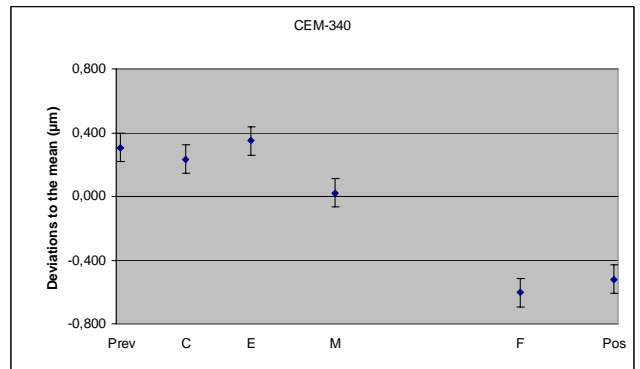

Fig. 6 (q)

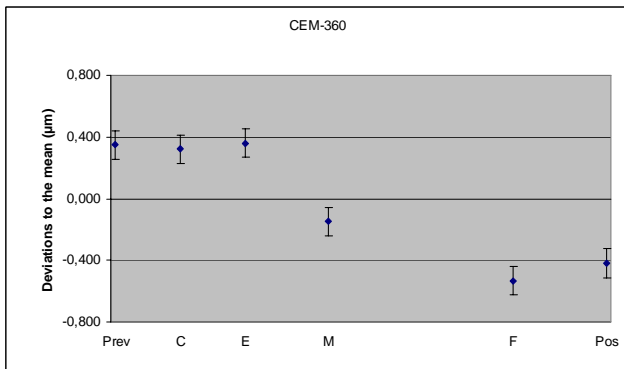

Fig. 6 (r)

Gauge 10

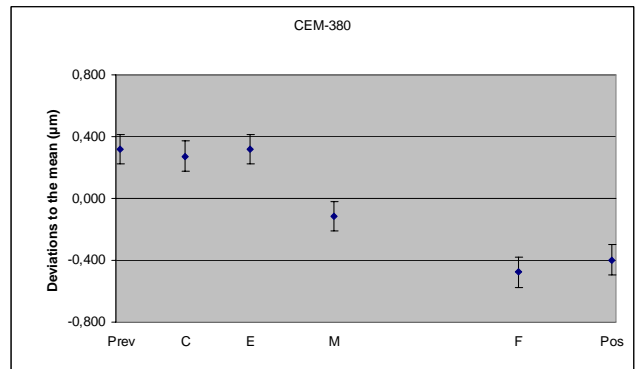

Fig. 6 (s)

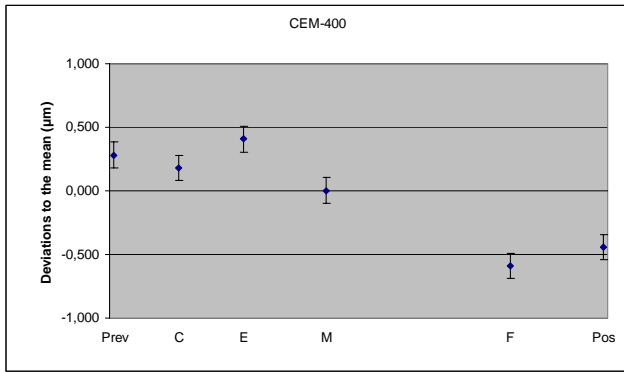

Fig. 6 (t)

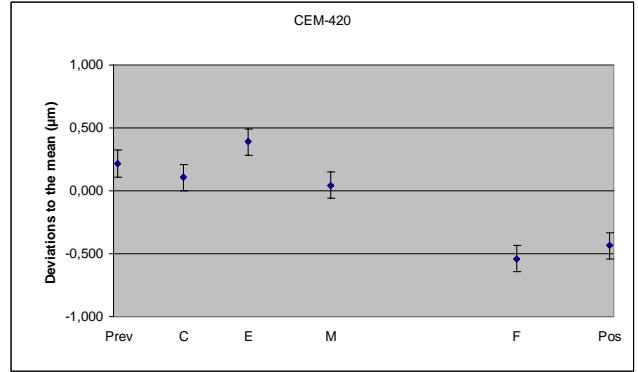

Fig. 6 (u)

Gauge 11

Uncertainty bars in above Figures 6(a) through 6(u) are standard uncertainties of the pilot laboratory’s usual measurement technique.

Looking at the above graphs it is clear that F results (CEM4) are not in agreement with the previous results for most of the gauges.

According to its quality system, CEM verifies periodically the metrological behaviour of the comparator. After observing such results, CEM measured the step it uses for such periodical checking, founding results consistent with the historical records and the corresponding CMC.

Next figure shows the results of measuring a 450 mm witness step of CEM since 1994:

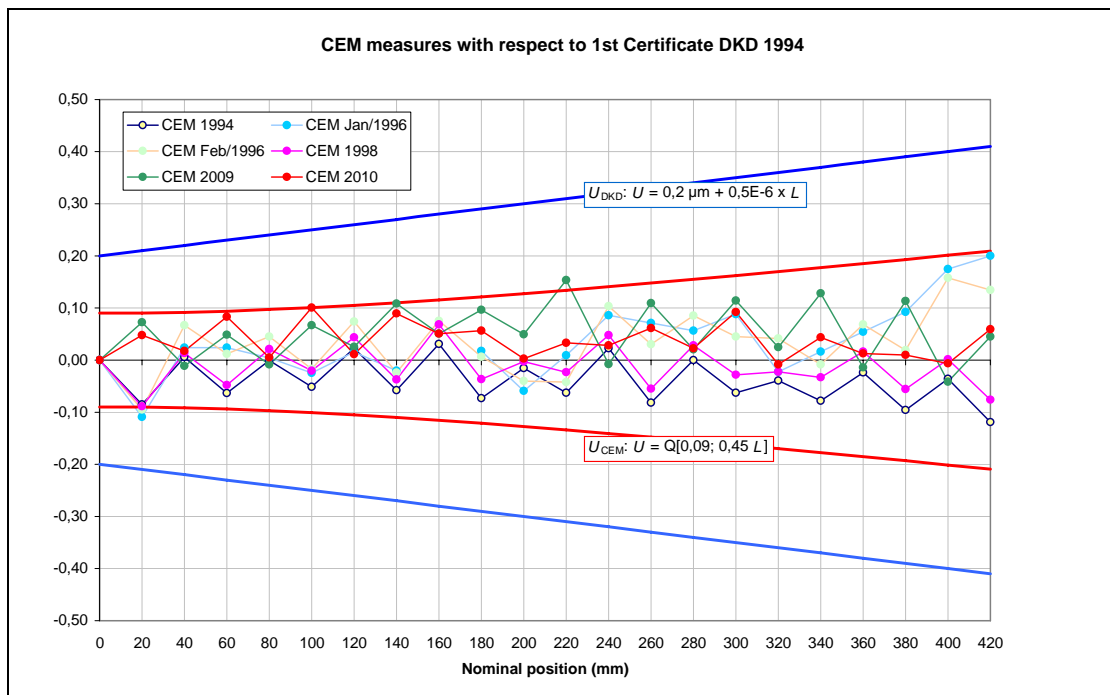

Such estrange results had been also obtained by the last participant in the comparison (CENAM) before CEM4 measurements and were also confirmed again by a subsequent measurement (Pos) realized by CEM ten months after concluding the comparison.

This clearly confirms the instability of the step due to a displacement of the gauges, making impossible to treat all comparison data equally.

6 Measurement results, as reported by participants

Next table shows all data, as communicated by participants, including the four measurements realized by CEM along the comparison. All values are given in mm.

Gauge	Face	mm	CEM1	BEV	NML	OMH	SP	CEM2	CGM
1	1	0	0.000 00	0.000 00	0.000 00	0.000 00	0.000 00	0.000 00	0.000 00
	2	20	20.001 63	20.001 39	20.001 70	20.001 90	20.001 52	20.001 62	20.001 57
2	3	40	40.016 31	40.016 59	40.016 64	40.016 60	40.016 52	40.016 44	40.016 49
	4	60	60.017 79	60.017 90	60.018 39	60.018 10	60.017 94	60.017 91	60.017 91
3	5	80	80.019 42	80.019 80	80.019 56	80.019 80	80.019 56	80.019 61	80.019 52
	6	100	100.020 54	100.020 46	100.021 03	100.021 90	100.020 62	100.020 73	100.020 69
4	7	120	120.023 24	120.023 72	120.023 25	120.024 10	120.023 32	120.023 49	120.023 37
	8	140	140.024 19	140.024 14	140.024 50	140.025 10	140.024 25	140.024 49	140.024 34
5	9	160	160.026 25	160.026 60	160.026 15	160.027 00	160.026 35	160.026 35	160.026 30
	10	180	180.027 38	180.027 07	180.027 85	180.028 00	180.027 42	180.027 49	180.027 32
6	11	200	200.043 57	200.043 70	200.043 20	200.043 80	200.043 63	200.043 70	200.043 59
	12	220	220.044 54	220.044 04	220.044 80	220.044 80	220.044 54	220.044 69	220.044 55
7	13	240	240.048 80	240.048 83	240.049 27	240.048 90	240.048 87	240.048 77	240.049 00
	14	260	260.050 62	260.049 83	260.051 06	260.050 70	260.050 62	260.050 61	260.050 70
8	15	280	280.058 00	280.058 41	280.057 98	280.058 20	280.058 23	280.058 24	280.058 00
	16	300	300.059 51	300.058 93	300.059 75	300.059 60	300.059 66	300.059 78	300.059 46
9	17	320	320.075 37	320.075 40	320.075 06	320.075 60	320.075 50	320.075 49	320.075 32
	18	340	340.076 98	340.076 48	340.077 34	340.077 20	340.077 03	340.077 10	340.076 89
10	19	360	360.085 22	360.084 89	360.085 09	360.085 50	360.085 27	360.085 26	360.085 25
	20	380	380.086 29	380.085 51	380.086 40	380.086 20	380.086 28	380.086 34	380.086 34
11	21	400	400.091 77	400.091 55	400.091 87	400.092 20	400.092 00	400.091 99	400.092 01
	22	420	420.092 77	420.092 19	420.093 22	420.093 00	420.092 97	420.093 05	420.092 87

Gauge	Face	mm	CMI	LNE	INM	IMRIM	NPL	CEM3	NRC
1	1	0	0.000 00	0.000 00	0.000 00	0.000 00	0.000 00	0.000 00	0.000 00
	2	20	20.001 51	20.001 38	20.000 79	20.001 73	20.001 68	20.001 65	20.001 50
2	3	40	40.016 54	40.016 74	40.016 98	40.016 63	40.016 69	40.016 48	40.016 59
	4	60	60.017 89	60.017 99	60.017 75	60.018 13	60.018 15	60.018 01	60.017 95
3	5	80	80.019 61	80.019 84	80.020 30	80.019 62	80.019 74	80.019 49	80.019 59
	6	100	100.020 61	100.020 69	100.020 47	100.020 75	100.020 84	100.020 66	100.020 65
4	7	120	120.023 41	120.023 69	120.024 23	120.023 39	120.023 49	120.023 26	120.023 43
	8	140	140.024 26	140.024 52	140.024 40	140.024 39	140.024 48	140.024 32	140.024 31
5	9	160	160.026 39	160.026 42	160.026 92	160.026 11	160.026 20	160.026 00	160.026 09
	10	180	180.027 38	180.027 38	180.027 27	180.027 24	180.027 30	180.027 18	180.027 09
6	11	200	200.043 69	200.043 98	200.044 38	200.043 77	200.043 87	200.043 69	200.043 79
	12	220	220.044 54	220.044 84	220.044 68	220.044 74	220.044 80	220.044 72	220.044 69
7	13	240	240.049 10	240.049 77	240.049 97	240.049 50	240.049 55	240.049 43	240.049 52
	14	260	260.050 76	260.051 31	260.050 95	260.051 22	260.051 32	260.051 26	260.051 26
8	15	280	280.058 24	280.058 31	280.058 60	280.057 80	280.057 90	280.057 66	280.057 85
	16	300	300.059 55	300.059 70	300.059 07	300.059 32	300.059 43	300.059 23	300.059 19
9	17	320	320.075 52	320.075 71	320.075 60	320.075 22	320.075 33	320.075 14	320.075 27
	18	340	340.076 99	340.077 05	340.076 46	340.076 82	340.076 91	340.076 77	340.076 75
10	19	360	360.085 29	360.085 31	360.085 10	360.084 78	360.084 92	360.084 75	360.084 88
	20	380	380.086 27	380.086 09	380.085 67	380.085 92	380.086 02	380.085 90	380.085 88
11	21	400	400.092 06	400.092 27	400.092 67	400.091 65	400.091 90	400.091 59	400.091 85
	22	420	420.093 06	420.093 27	420.092 79	420.092 79	420.092 94	420.092 71	420.092 75

Gauge	Face	mm	NMIA	VNIIM	MIKES	VSL	GUM	INMETRO	CENAM	CEM4
1	1	0	0.000 00	0.000 00	0.000 00	0.000 00	0.000 00	0.000 00	0.000 00	0.000 00
	2	20	20.001 66	20.001 30	20.001 56	20.001 60	20.001 50	20.001 72	20.001 45	20.001 67
2	3	40	40.016 53	40.004 10	40.016 72	40.016 70	40.016 40	40.016 59	40.016 20	40.016 16
	4	60	60.018 16	60.007 30	60.018 11	60.018 05	60.018 10	60.018 05	60.017 51	60.017 66
3	5	80	80.019 54	80.017 30	80.019 75	80.019 65	80.019 30	80.019 67	80.019 53	80.019 45
	6	100	100.020 91	100.019 60	100.020 78	100.020 70	100.021 30	100.020 74	100.020 59	100.020 59
4	7	120	120.023 45	120.035 80	120.023 60	120.023 47	120.023 10	120.023 49	120.022 90	120.022 77
	8	140	140.024 54	140.037 60	140.024 51	140.024 40	140.024 70	140.024 35	140.023 81	140.023 77
5	9	160	160.026 20	160.045 20	160.026 19	160.026 05	160.025 80	160.025 83	160.025 12	160.025 13
	10	180	180.027 37	180.048 20	180.027 24	180.027 09	180.027 50	180.026 92	180.026 11	180.026 24
6	11	200	200.043 90	200.051 00	200.043 82	200.043 67	200.044 50	200.044 31	200.043 18	200.043 09
	12	220	220.044 95	220.052 20	220.044 76	220.044 56	220.045 40	220.045 19	220.044 06	220.044 11
7	13	240	240.049 76	240.067 50	240.049 46	240.049 28	240.049 60	240.049 62	240.048 93	240.048 91
	14	260	260.051 56	260.069 50	260.051 15	260.051 01	260.051 60	260.051 29	260.050 57	260.050 77
8	15	280	280.058 04	280.072 10	280.057 87	280.057 71	280.057 90	280.057 83	280.057 23	280.057 01
	16	300	300.059 64	300.072 30	300.059 31	300.059 15	300.059 60	300.059 23	300.058 64	300.058 59
9	17	320	320.075 53	320.075 10	320.075 26	320.075 10	320.076 30	320.075 82	320.074 53	320.074 51
	18	340	340.077 15	340.078 20	340.076 77	340.076 62	340.077 70	340.077 31	340.076 05	340.076 14
10	19	360	360.085 07	360.079 20	360.084 84	360.084 67	360.084 30	360.084 47	360.084 40	360.084 37
	20	380	380.086 07	380.080 00	380.085 80	380.085 67	380.085 50	380.085 50	380.085 58	380.085 54
11	21	400	400.091 98	400.095 10	400.091 85	400.091 68	400.091 30	400.091 78	400.091 28	400.091 00
	22	420	420.093 12	420.094 70	420.092 82	420.092 66	420.092 90	420.092 81	420.092 31	420.092 13

Table 4 – Measurement results, as communicated by the participants.

7 Measurement uncertainties

The technical protocol specified that the uncertainty of measurement should be estimated according to the ISO Guide to the Expression of Uncertainty in Measurement. Typical uncertainties u (1σ) communicated by the participants are shown in the following table:

Participant	u (1σ)	Participant	u (1σ)
CEM	$u = q[45 ; 0.225 \text{ L/mm}] \text{ nm}$	NPL	$u = q[0.05 ; 0.207 \times 10^{-3} \text{ L}] \mu\text{m}$
BEV	$u = q[0.56 ; 1.14 \times 10^{-3} \text{ L}] \mu\text{m}$	NRC	$u = q[0.11 ; 0.24 \text{ L/mm}] \mu\text{m}$
NML	$u = q[1.11 ; 0.2 \times 10^{-3} \text{ L/mm}] \mu\text{m}$	NMIA	$u = q[0.19 ; 0.73 \text{ L/mm}] \mu\text{m}$
OMH	$u = q[0.44 ; 1.4 \text{ L/mm}] \mu\text{m}$	VNIIM	$u = q[0.77 ; 1.17 \times 10^{-3} \text{ L/m}] \mu\text{m}$
SP	$u = q[68 ; 1.3 \times 10^{-7} \text{ L}] \text{ nm}$	MIKES	$u = q[0.077 ; 1.26 \times 10^{-4} \text{ L/mm}] \mu\text{m}$
CGM	$u = q[0.2 ; 0.4 \times 10^{-6} \text{ L}] \mu\text{m}$	VSL	$u = q[0.075 ; 5.6 \times 10^{-4} \text{ L/m}] \mu\text{m}$
CMI	$u = q[0.15 ; 0.46 \times 10^{-3} \text{ L/mm}] \mu\text{m}$	GUM	$u = q[0.41 ; 0.53 \text{ L/m}] \mu\text{m}$
LNE	$u = q[166 ; 0.72 \text{ L/mm}] \text{ nm}$	INMETRO	$u = q[0.15 ; 0.4 \times 10^{-3} \text{ L/mm}] \mu\text{m}$
INM	$u = q[0.47 ; 0.001 \text{ L/mm}] \mu\text{m}$	CENAM	$u = q[0.16 ; 0.25 \text{ L/m}] \mu\text{m}$
INRIM	$u = q[0.1 ; 0.35 \times 10^{-3} \text{ L/mm}] \mu\text{m}$		

Next Table shows the standard uncertainties, in μm , for all faces of the step:

Gauge	Face	mm	CEM	BEV	NML	OMH	SP	CGM	CMI	LNE	INM
1	1	0	0.045	0.50	1.100	0.440	0.068	0.200	0.154	0.166	0.47
	2	20	0.045	0.56	1.100	0.441	0.071	0.200	0.154	0.167	0.47
2	3	40	0.046	0.50	1.100	0.444	0.073	0.201	0.155	0.168	0.47
	4	60	0.047	0.56	1.100	0.448	0.076	0.201	0.157	0.172	0.47
3	5	80	0.048	0.51	1.100	0.454	0.078	0.203	0.158	0.176	0.48
	6	100	0.050	0.57	1.100	0.462	0.081	0.204	0.161	0.181	0.48
4	7	120	0.052	0.52	1.100	0.471	0.084	0.206	0.164	0.187	0.49
	8	140	0.055	0.58	1.100	0.482	0.086	0.208	0.167	0.194	0.49
5	9	160	0.058	0.53	1.100	0.494	0.089	0.210	0.171	0.202	0.50
	10	180	0.061	0.60	1.100	0.507	0.091	0.213	0.175	0.211	0.50
6	11	200	0.064	0.55	1.100	0.522	0.094	0.215	0.180	0.220	0.51
	12	220	0.067	0.61	1.100	0.537	0.097	0.219	0.185	0.229	0.52
7	13	240	0.070	0.57	1.200	0.554	0.099	0.222	0.190	0.240	0.53
	14	260	0.074	0.63	1.200	0.571	0.102	0.225	0.196	0.250	0.54
8	15	280	0.077	0.59	1.200	0.589	0.104	0.229	0.202	0.261	0.55
	16	300	0.081	0.66	1.200	0.608	0.107	0.233	0.208	0.272	0.56
9	17	320	0.085	0.62	1.200	0.628	0.110	0.237	0.214	0.284	0.57
	18	340	0.089	0.68	1.200	0.648	0.112	0.242	0.220	0.296	0.58
10	19	360	0.093	0.65	1.200	0.669	0.115	0.246	0.227	0.308	0.59
	20	380	0.097	0.71	1.200	0.690	0.117	0.251	0.234	0.320	0.60
11	21	400	0.101	0.68	1.200	0.712	0.120	0.256	0.241	0.332	0.62
	22	420	0.105	0.74	1.200	0.734	0.123	0.261	0.248	0.345	0.63

Gauge	Face	mm	INRIM (*)	NPL	NRC	NMIA	VNIIM	MIKES	VSL	GUM	INMETRO	CENAM
1	1	0	0.100	0.050	0.110	0.190	0.770	0.077	0.075	0.410	0.150	0.160
	2	20	0.100	0.050	0.110	0.190	0.770	0.077	0.076	0.410	0.151	0.161
2	3	40	0.101	0.051	0.110	0.190	0.771	0.077	0.078	0.411	0.151	0.161
	4	60	0.102	0.052	0.111	0.190	0.773	0.077	0.082	0.411	0.152	0.161
3	5	80	0.104	0.053	0.112	0.200	0.776	0.078	0.087	0.412	0.154	0.162
	6	100	0.106	0.054	0.113	0.200	0.779	0.078	0.094	0.413	0.156	0.162
4	7	120	0.108	0.056	0.114	0.210	0.783	0.078	0.101	0.415	0.158	0.163
	8	140	0.111	0.058	0.115	0.220	0.787	0.079	0.109	0.417	0.161	0.164
5	9	160	0.115	0.060	0.117	0.220	0.792	0.080	0.117	0.419	0.164	0.165
	10	180	0.118	0.062	0.118	0.230	0.798	0.080	0.126	0.421	0.167	0.167
6	11	200	0.122	0.065	0.120	0.240	0.805	0.081	0.135	0.423	0.170	0.168
	12	220	0.126	0.068	0.122	0.250	0.812	0.082	0.144	0.426	0.174	0.170
7	13	240	0.131	0.070	0.124	0.260	0.820	0.083	0.154	0.429	0.179	0.171
	14	260	0.135	0.073	0.126	0.270	0.828	0.084	0.164	0.433	0.183	0.173
8	15	280	0.140	0.077	0.129	0.280	0.837	0.085	0.174	0.436	0.188	0.175
	16	300	0.145	0.080	0.131	0.290	0.846	0.086	0.184	0.440	0.193	0.177
9	17	320	0.150	0.083	0.134	0.300	0.856	0.087	0.194	0.444	0.198	0.179
	18	340	0.155	0.086	0.137	0.310	0.867	0.088	0.205	0.448	0.203	0.182
10	19	360	0.161	0.090	0.140	0.320	0.878	0.089	0.215	0.452	0.208	0.184
	20	380	0.166	0.093	0.143	0.340	0.889	0.091	0.226	0.457	0.214	0.187
11	21	400	0.172	0.097	0.146	0.350	0.901	0.092	0.236	0.462	0.220	0.189
	22	420	0.178	0.100	0.149	0.360	0.914	0.093	0.247	0.467	0.226	0.192

Table 5 – Measurement uncertainties $u(1\sigma)$, as communicated by the participants.

(*) **NOTE:** Just after the approval of Draft B report as Final Report, INRIM confirmed to a request of the Pilot, that the standard uncertainty values given in Table 5 (page 21) did correspond to expanded uncertainty (U_{95}) values, as included in the measurement report submitted by INRIM on Aug. 22, 2006 by e-mail, and not to the standard uncertainty equation indicated in the table at page 20. So, Table 5 has been consequently corrected, showing now the right INRIM u (1σ) values. As a consequence, all comparison figures have been recalculated by the Pilot, showing final negligible variations.
All participants maintain the level of consistency they had before such correction, including INRIM.

8 Analysis of the reported results, KCRVs and uncertainties

8.1 Initial considerations

The first premise of the Recommendations approved by CCL on obtaining key comparison reference values is the stability of the artefact. It has no sense to calculate any reference value if the stability of the artefact is under suspicion.

A step gauge may be considered as a long standard composed by many other standards (gauges), located in theoretically fixed positions. The stability of the step mainly depends on the expansion of the column supporting the gauges, the expansion of the gauges themselves and how well the gauges maintain fixed in their respective positions, when suffering expansion-contraction phenomena together with blows during transportation. If during transportation some of the gauges move, the stability of the full step may be lost and only some of the gauges may be considered to get individual RVs.

Any statistical analysis realized to get the corresponding RVs is based on the **hypothesis of the stability of the artefact**, on this case the step in full and the gauges inserted on it (no shift & no drift). If this is not true, the KC will be less valuable and even NMIs' CMCs may be put under discussion in case there is not a clear mathematical formulation for the behaviour of the artefact.

The expression for the uncertainty claimed by an NMI is based normally on laboratory conditions, particular equipment and the "stability" of the artefact at short term, not including long term effects. In a comparison, if the artefact is not sufficiently stable, the "small uncertainty" Labs. may fail the consistency test, although their results may truly represent the state of the artefact at the particular moment of its measurement.

Disagreements in the results may also come from several participants measuring a "different" measurand because probing not exactly in the centre of the faces or due to the poor flatness and parallelism of some of the faces, as it is the case according to the observations of some participants during their measurements.

Because the first face of the first gauge is the origin of measurements, in our case there are 21 measuring faces from which to obtain their deviations to nominal positions and the uncertainties of such deviations. So, we will get, in the best case, 21 RVs.

In this comparison, it was difficult to alert participants on any possible problem with their measurements because the apparent lack of stability in some gauges, confirmed by CEM by getting different results on these gauges each time the step was measured in Spain (see Fig. 5). Such movements were also confirmed when receiving new data from other participants, mainly those having a small uncertainty. This process caused the continuous updating of the reference values and their variation along the time. It was just at the end of the comparison, after receiving all data, when it was possible to start with the real study of all data. Anyway, the message sent by the Pilot to the participants (except VNIIM) was: "*Within the limits of our current estimate of the reference value, your measurements don't show any anomalous values*".

Next graphs show the values communicated by participants (Table 4), expressed now as deviations to the nominal positions, together with the standard uncertainties (Table 5) of such deviations for each face of the gauges of the step.

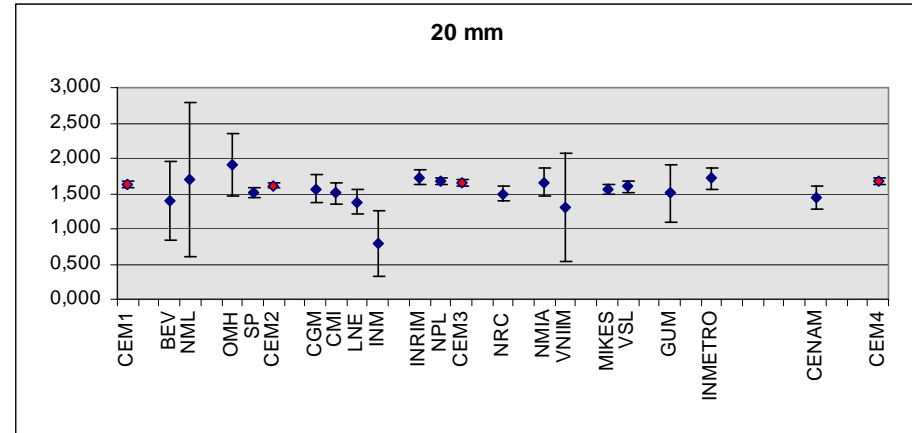

Gauge 1

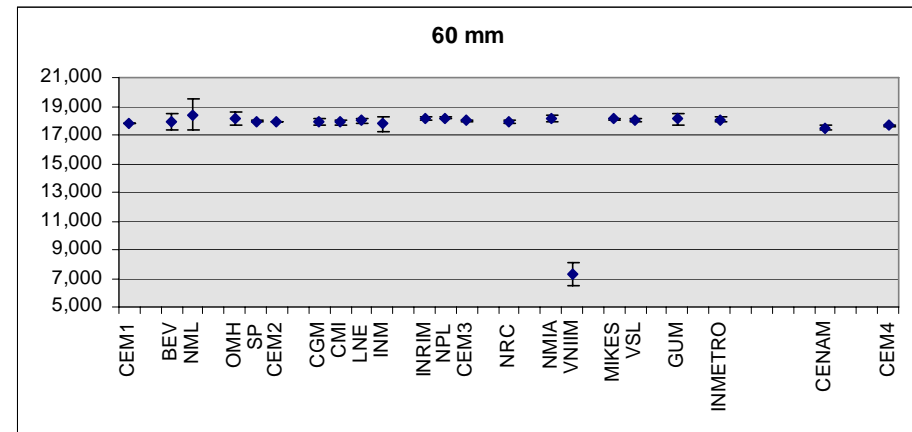
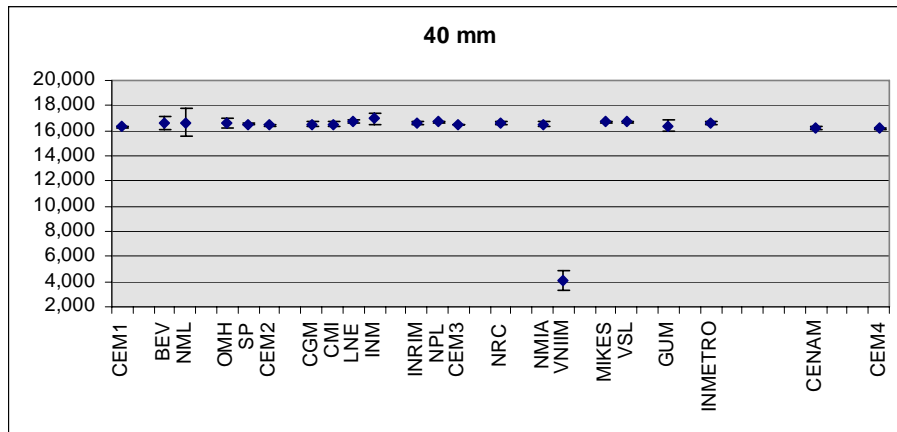

Gauge 2

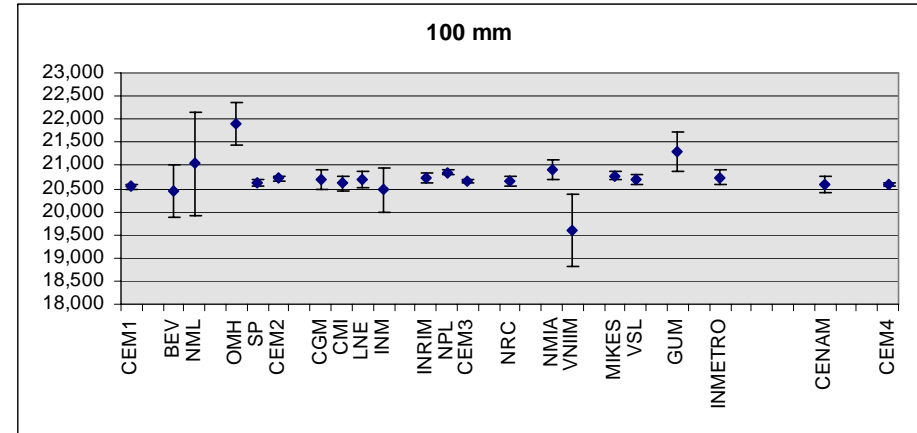
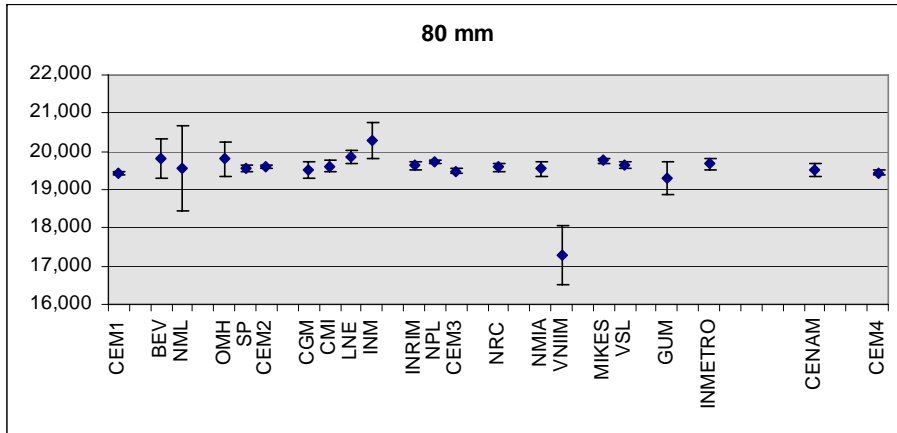

Gauge 3

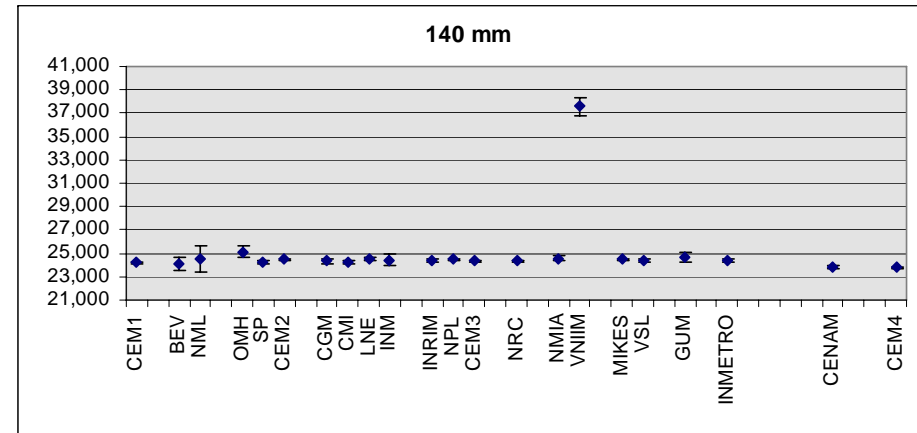
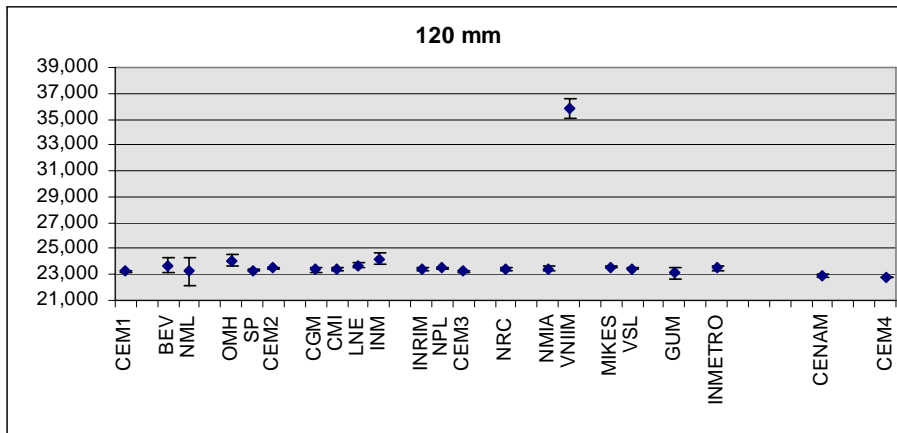

Gauge 4

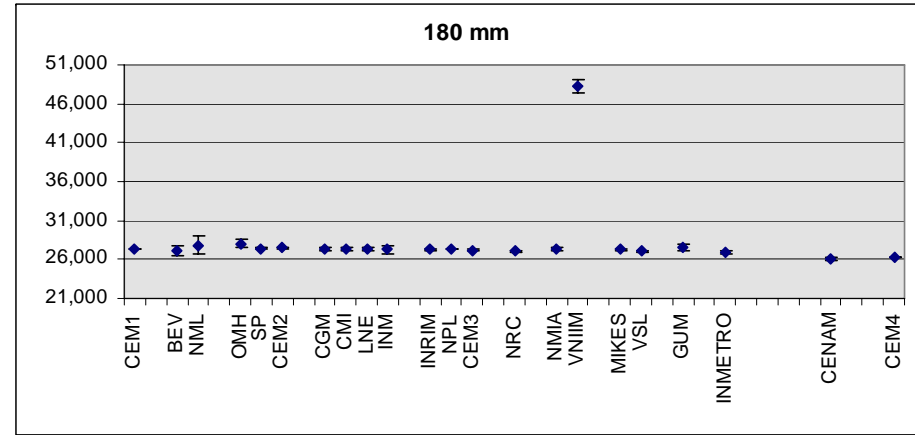
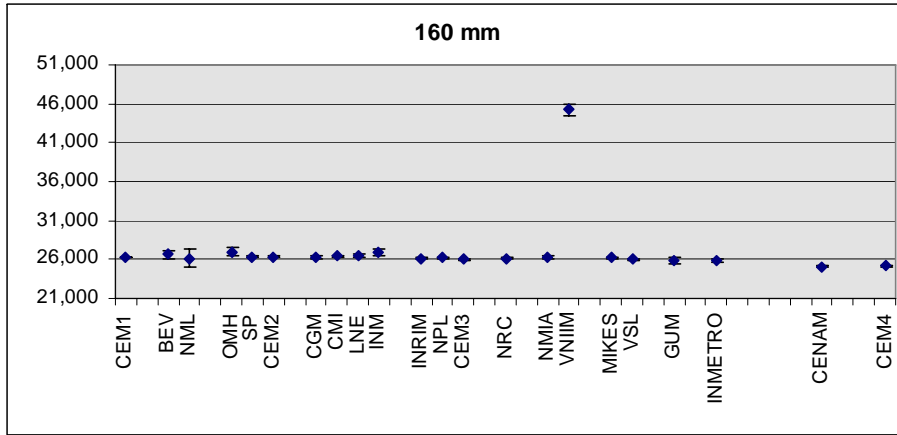

Gauge 5

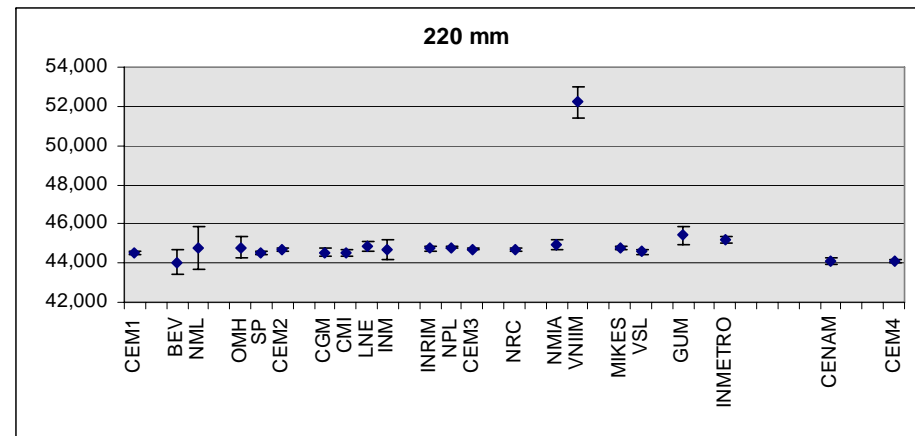
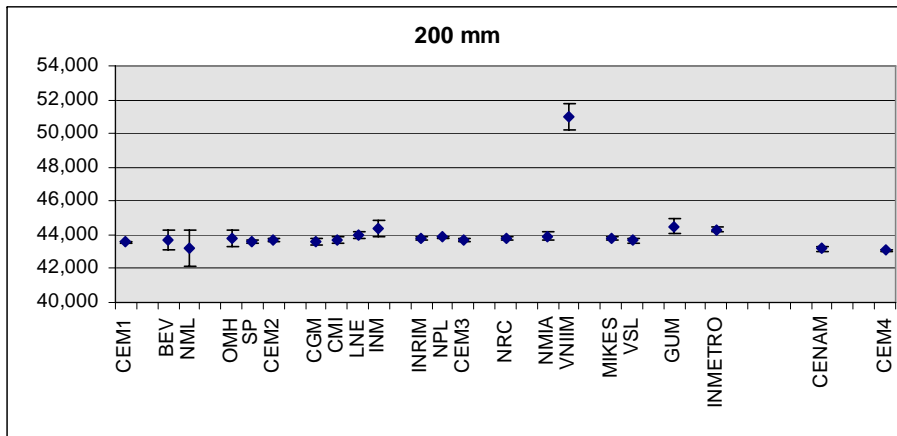

Gauge 6

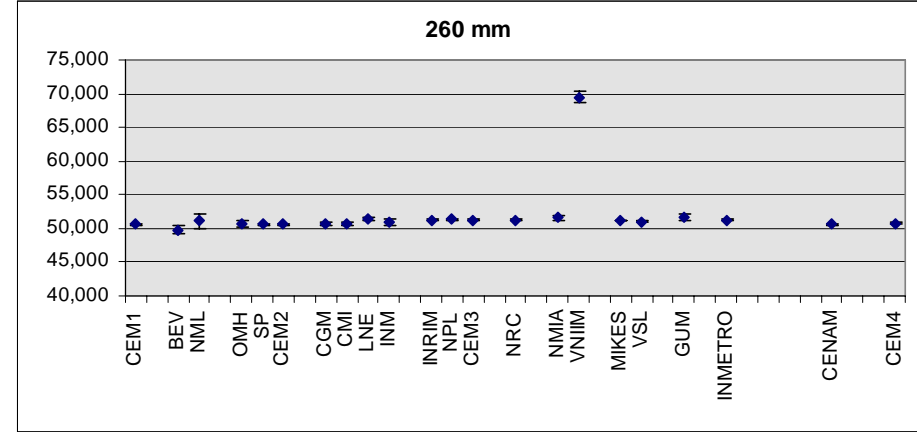
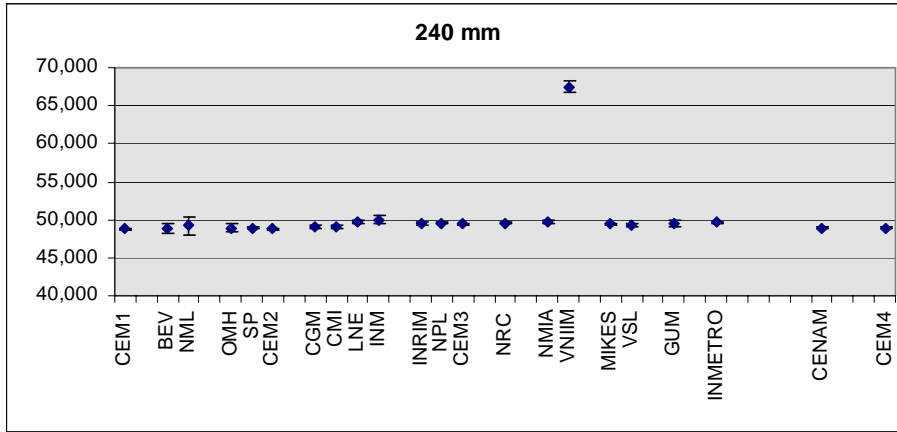

Gauge 7

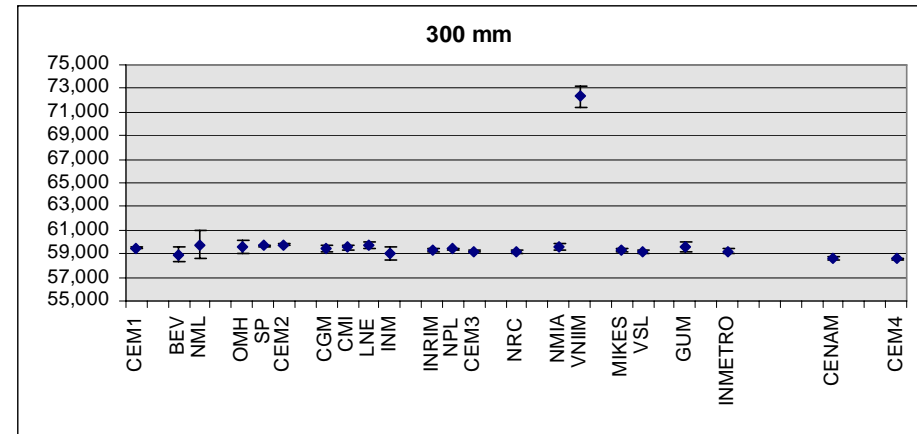
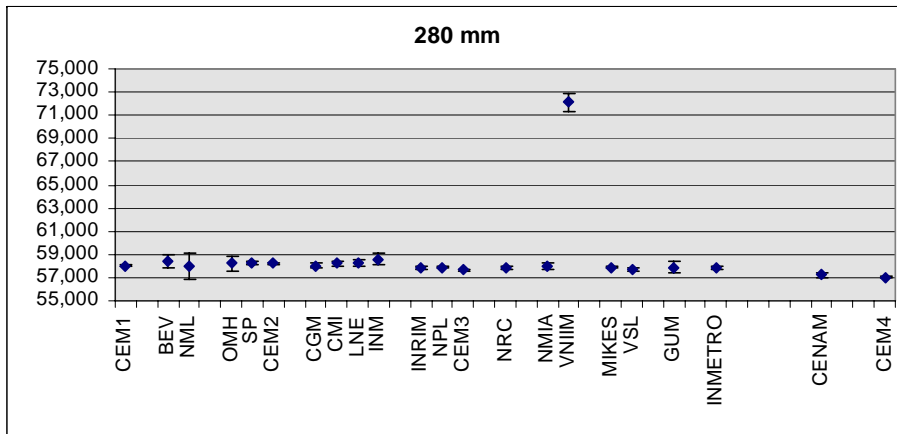

Gauge 8

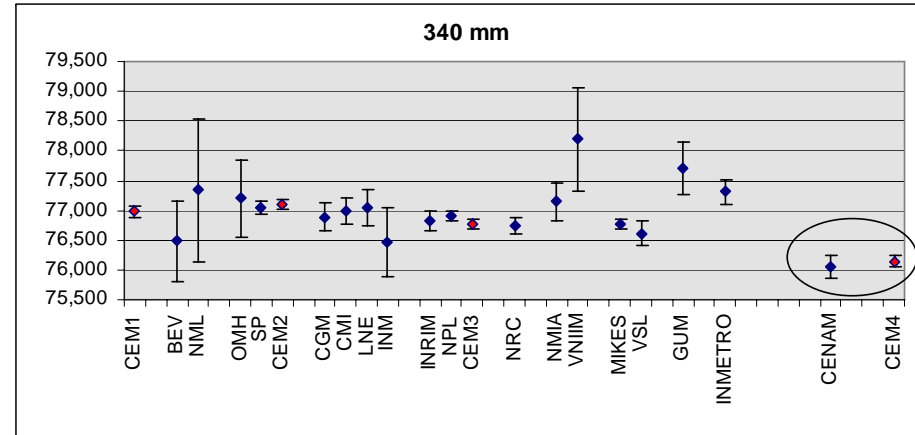
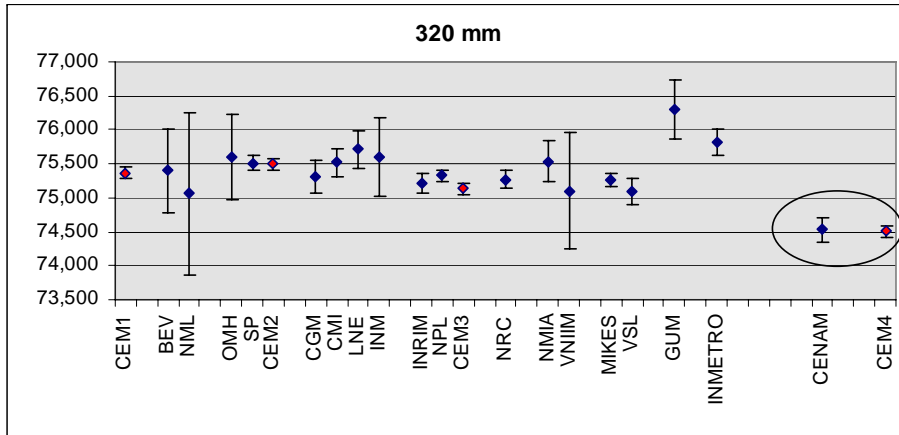

Gauge 9

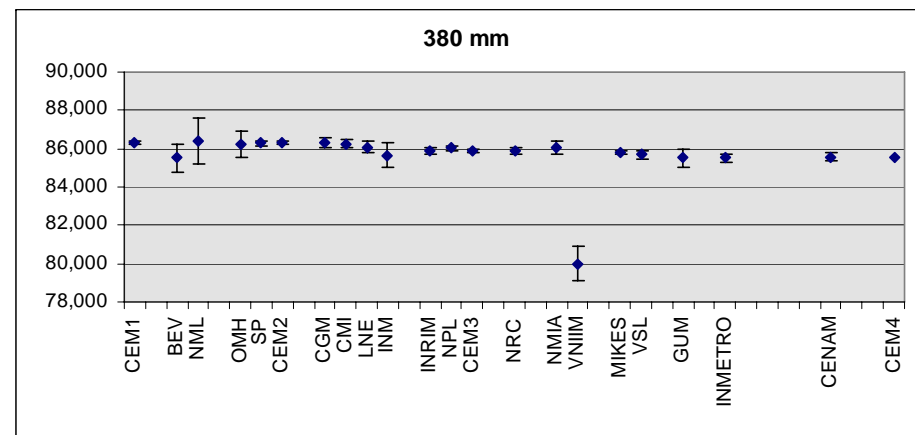
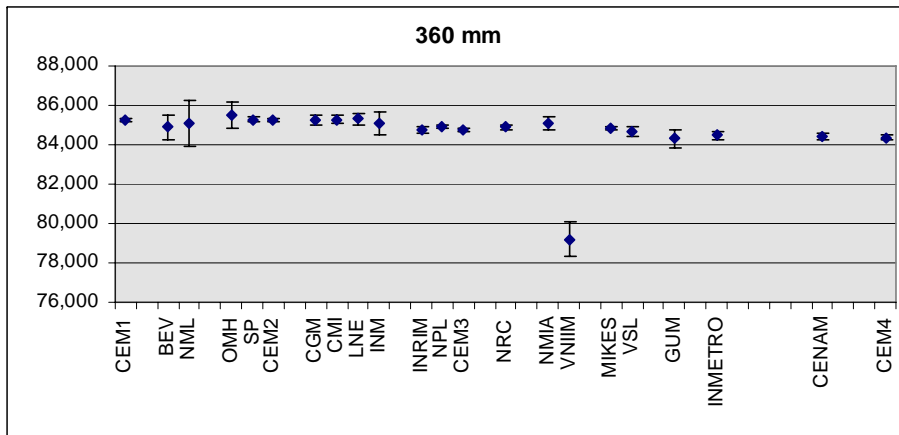

Gauge 10

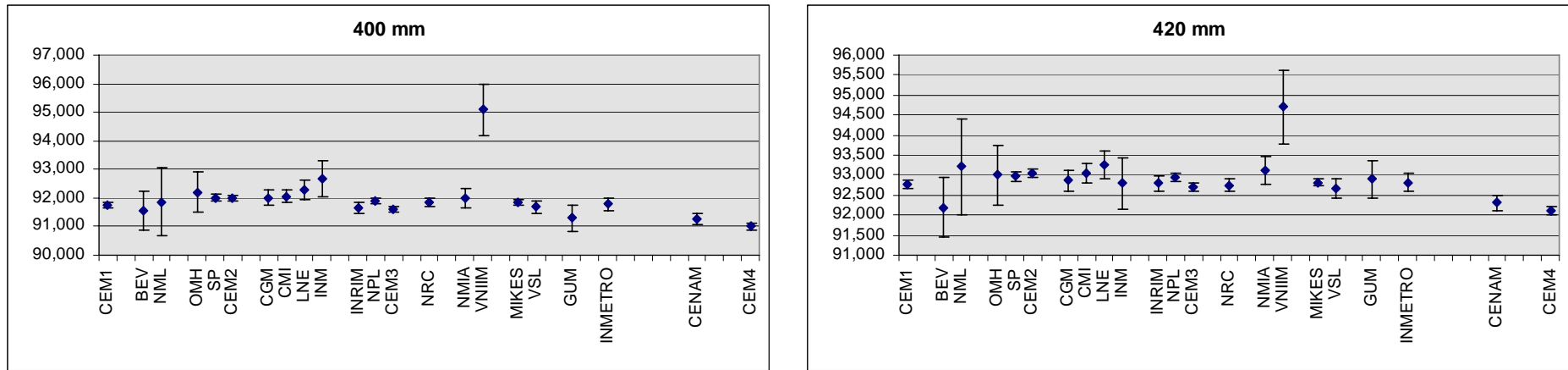

Gauge 11

Fig. 6 – Graphs of the deviations to the nominal position of the 21 faces (11 gauges) of the step, derived from the values communicated by participants.

In the above graphs, a strong systematic effect is observed for VNIIM, sometimes positive, sometimes negative, except for the 1st (20 mm) and 9th gauges (320 mm, 340 mm), showing results by far not consistent with the rest of participants. Although Pilot Lab. sent several e-mails and tried to contact VNIIM, unfortunately it never got an answer. Even after issued and sent the Draft A to participants, none communication was received.

By excluding VNIIM results in the rest of gauges, these are the new graphs obtained:

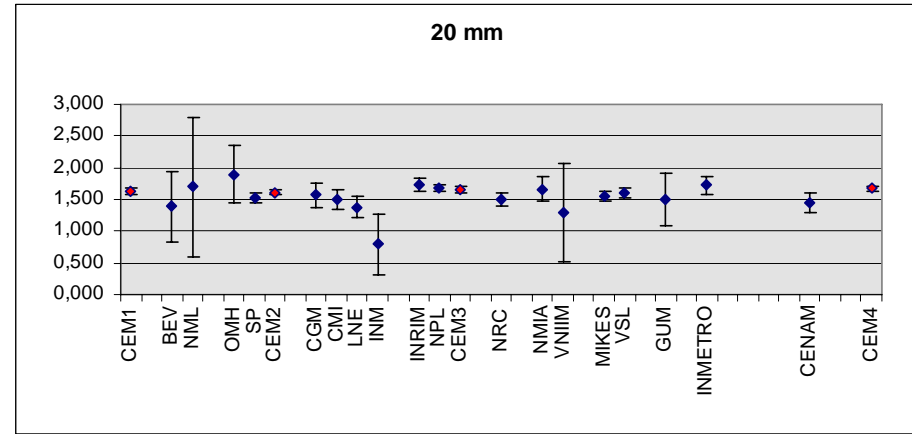

Gauge 1

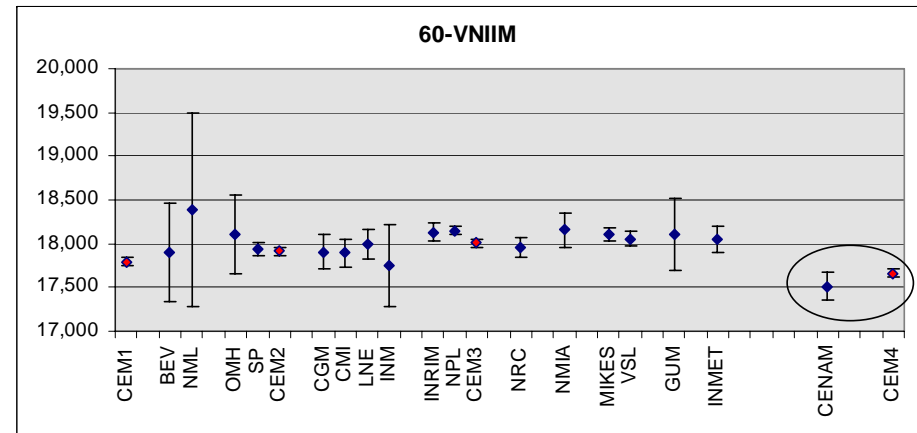
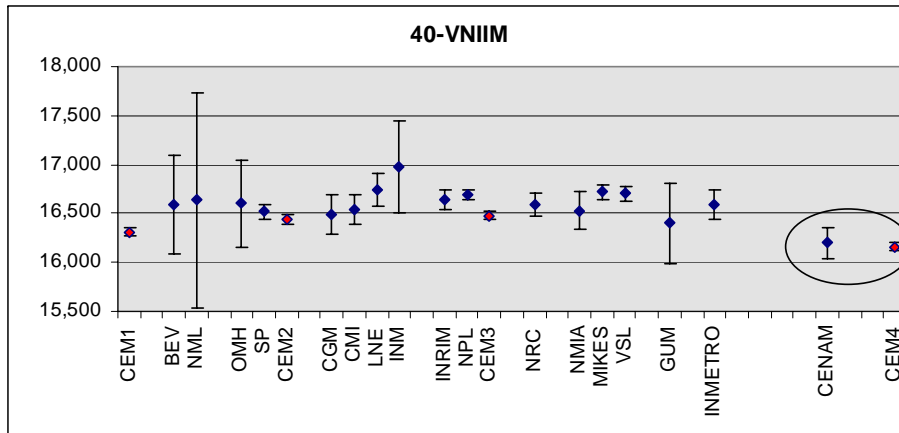

Gauge 2

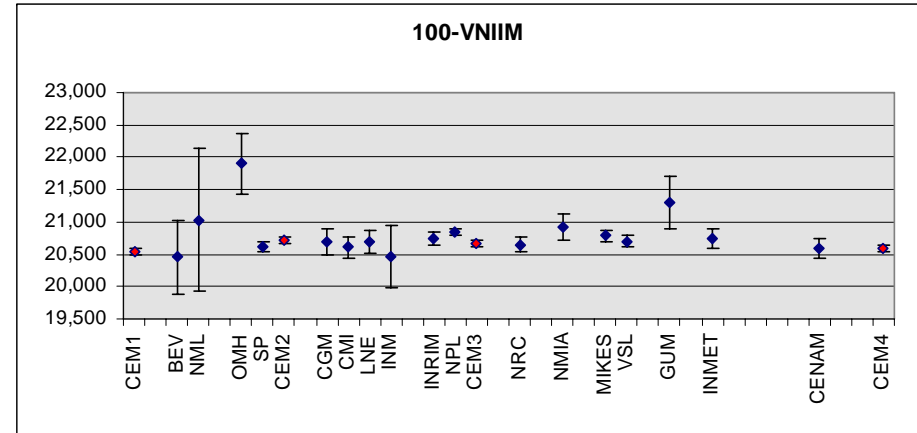
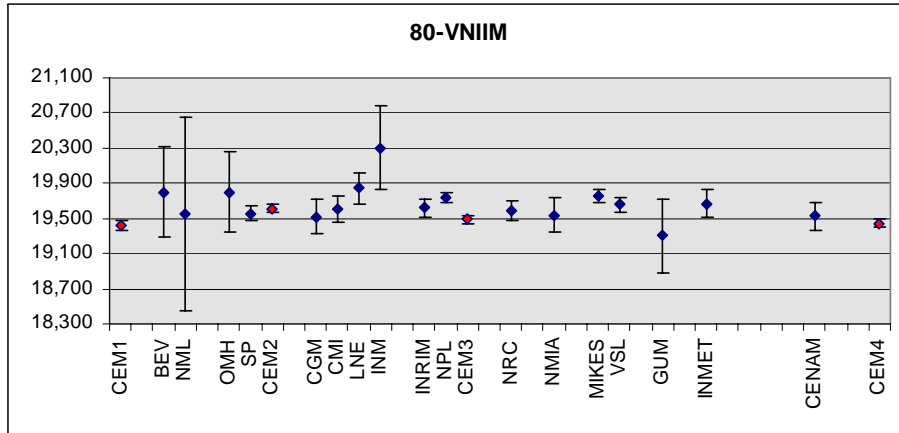

Gauge 3

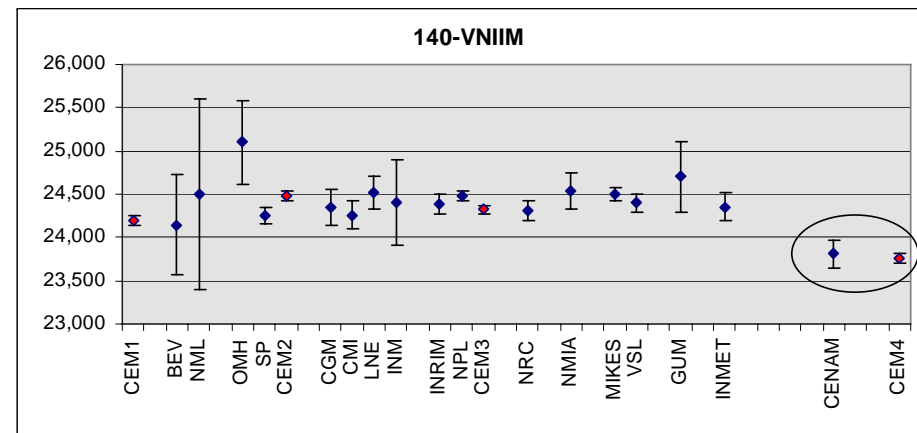
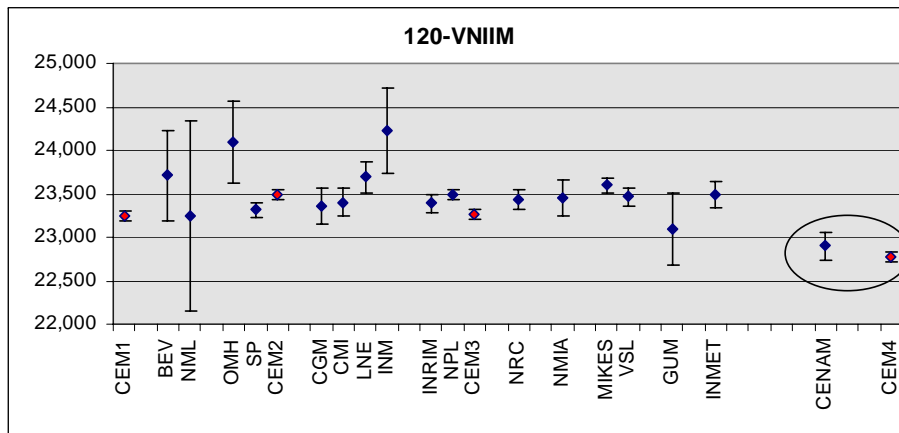

Gauge 4

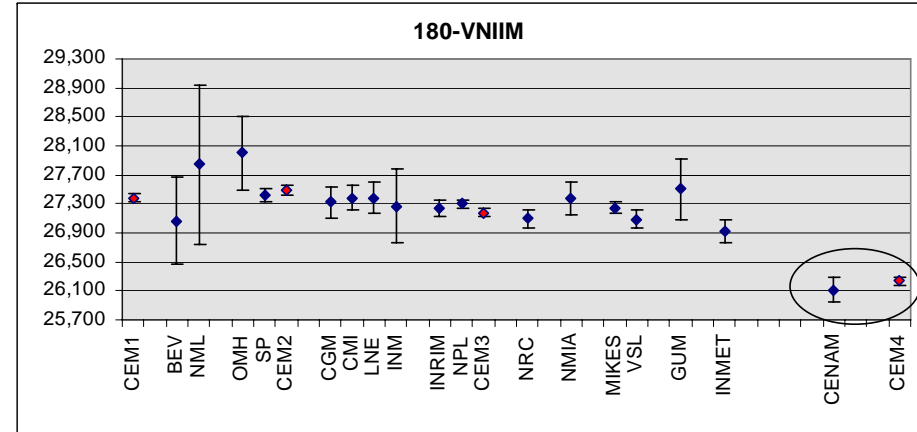
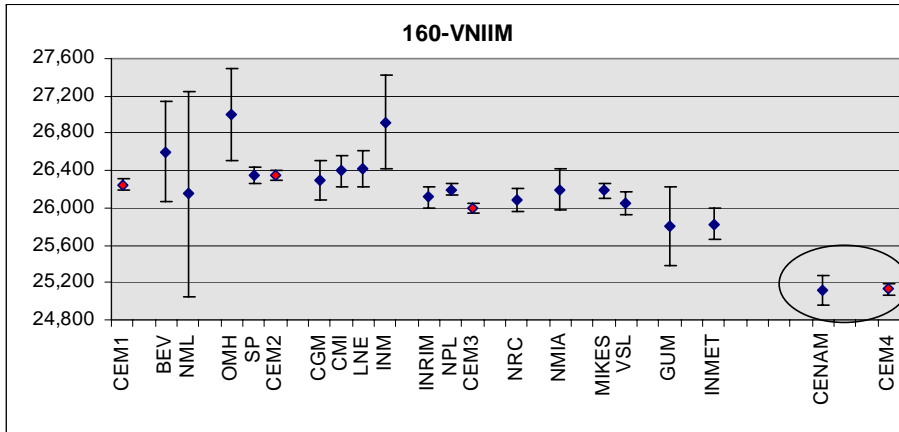

Gauge 5

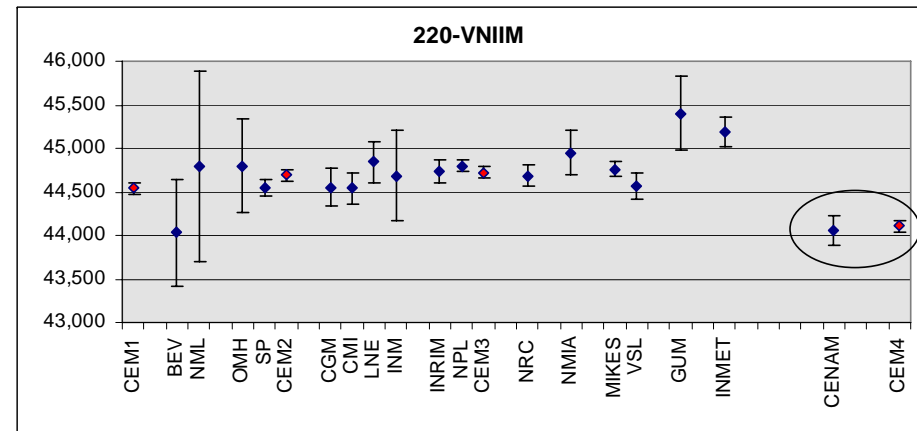
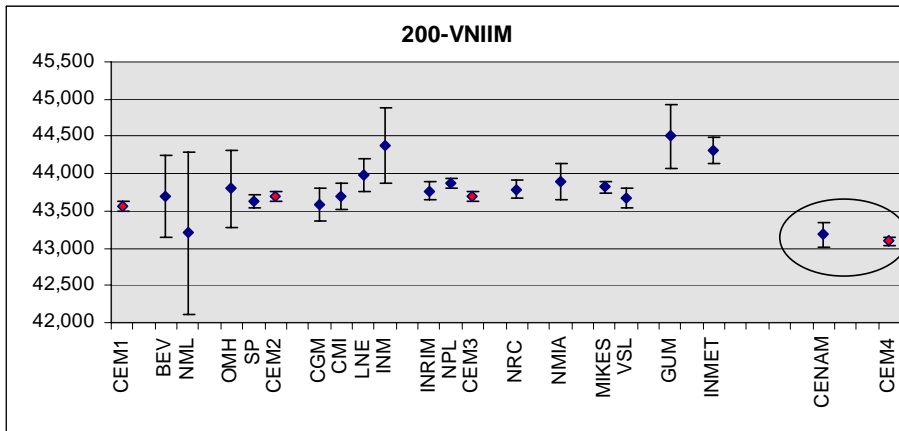

Gauge 6

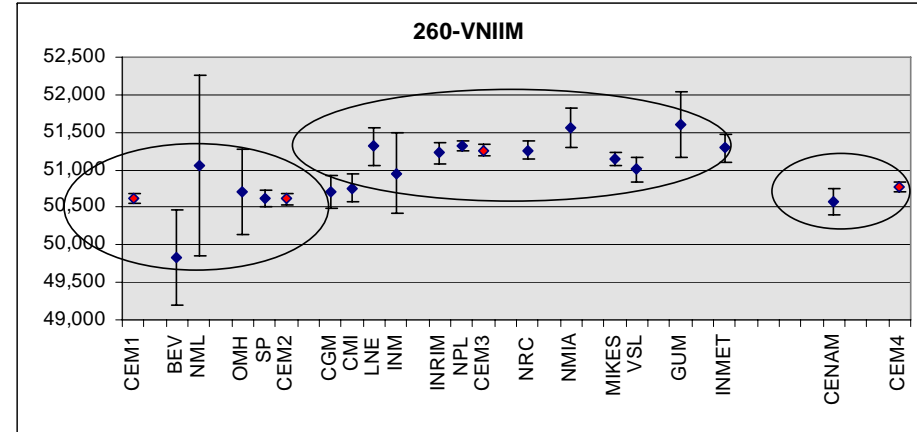
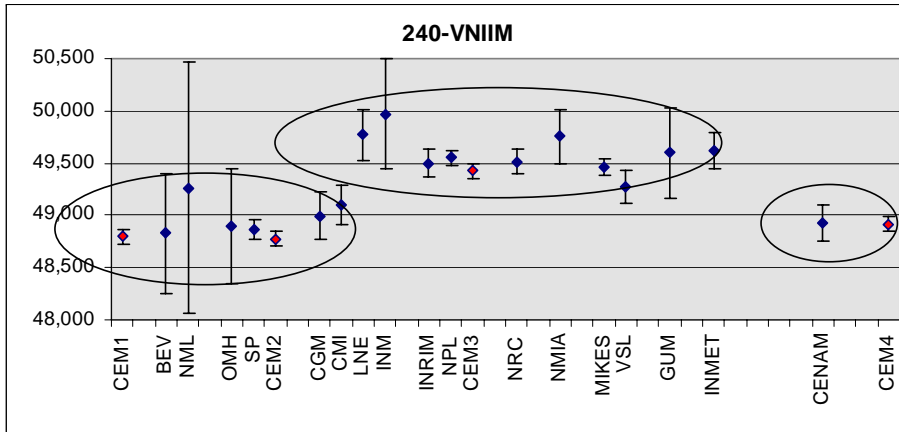

Gauge 7

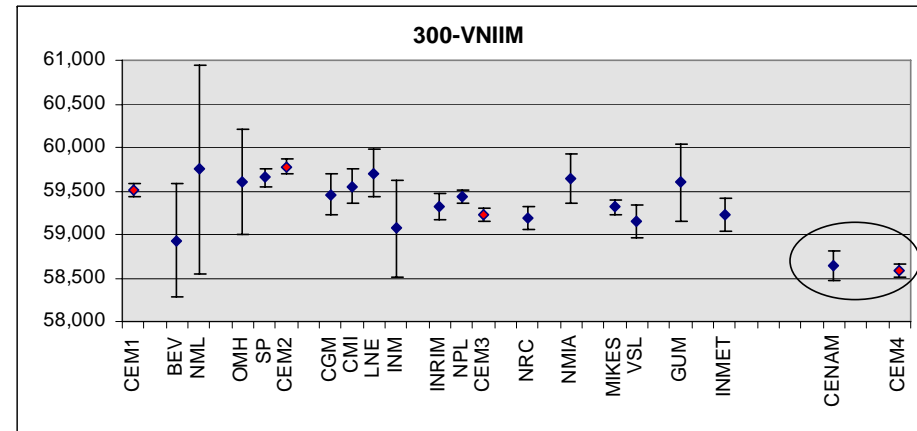
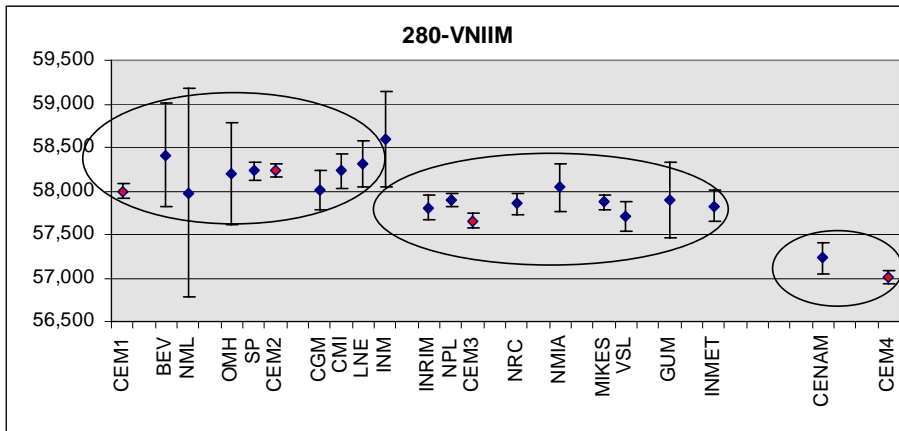

Gauge 8

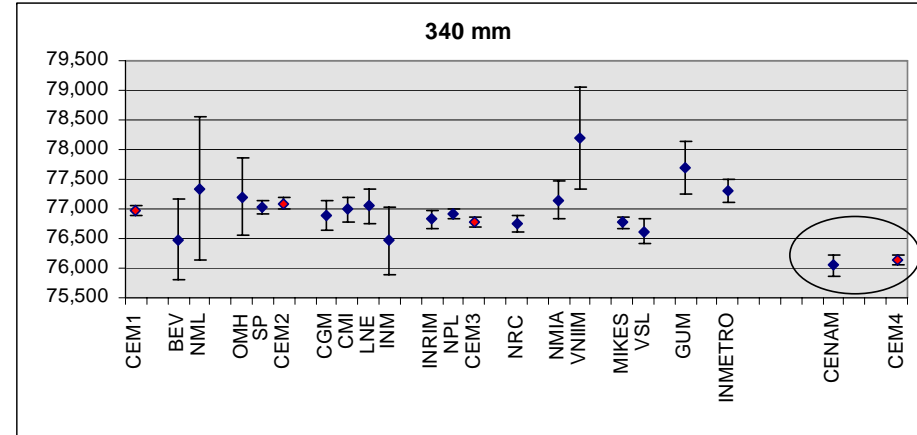
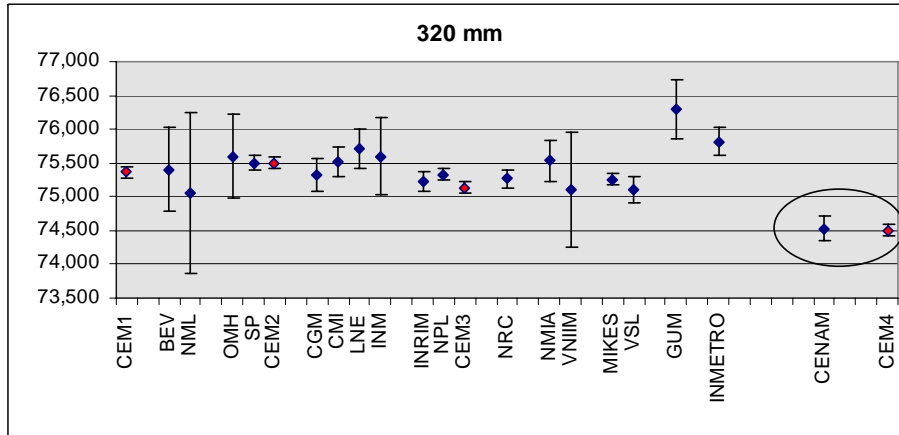

Gauge 9

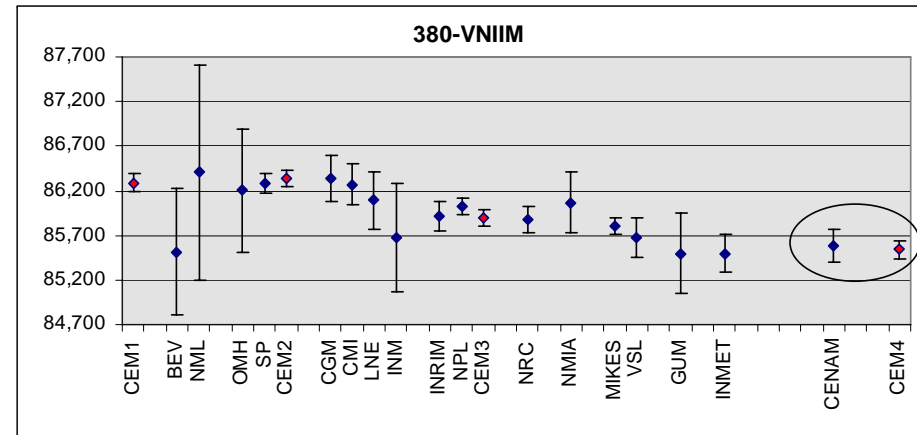
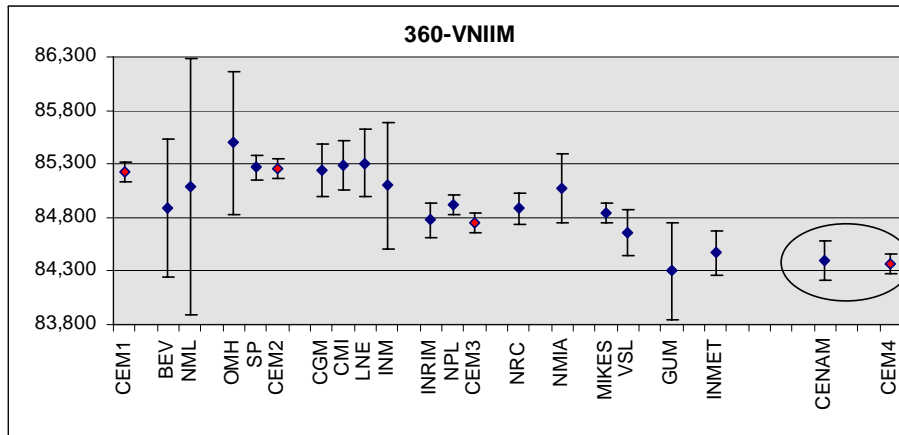

Gauge 10

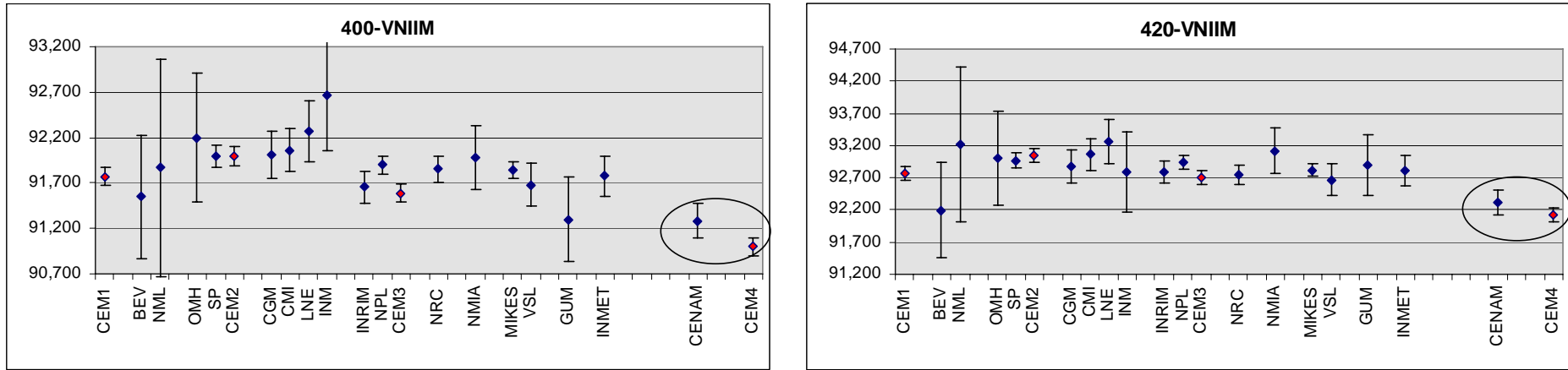

Gauge 11

Fig. 7 – Graphs of the deviations to the nominal position of the 21 faces (11 gauges) of the step, after excluding VNIIM results (except in gauges 1 & 9). Horizontal scale is in real time (months). CEM measurements along the time are indicated by a red dot.

Looking at the evolution of the results along the time (Fig.7), the following is observed:

1. It seems that many of the gauges have moved one or several times during the long duration of the comparison (graphs of gauges 7 and 8 show sets of results grouped around different nominal positions).
2. Although it is very hard to judge and argue when certain gauges have moved or not and how, something extreme happened to the step gauge between April 2007 and September 2007 (Observe how CENAM and CEM4 are very different to everybody else in all gauges after INMETRO measurements, perhaps with the exception of gauges 1 and 3).
3. Despite the gauges 5 and 10 seem to show a linear drift, there is no scientific argument to use time dependent drift correction for just these gauges.

As a consequence, in order to save the comparison and get valuable and useful conclusions, the following **actions** were taken:

1. **To exclude gauges 5, 7, 8 and 10 from calculation**, based on the large variations and anomalous behaviour observed on them by the Pilot Lab. and the participants (Fig. 7).
2. **Assume that only gauges 1, 2, 3, 4, 6, 9 and 11 are reasonably stable** along the comparison and use them for the analysis, trying to get the corresponding reference values (RVs). Although there is a reduction in the number of gauges, the number of remaining ones is still valid for checking the capability of participants to calibrate step gauges according to their CMCs.
3. **To leave out the results of CENAM and CEM4 and analyze them separately**, as a second group, linking later their results to the main group.

9 Main group: All participants except CENAM and CEM4

For this group, the stability of the step is judged looking at the three CEM measurements: at the beginning (CEM1), in the middle (CEM2) and at the end (CEM3) of the circulation.

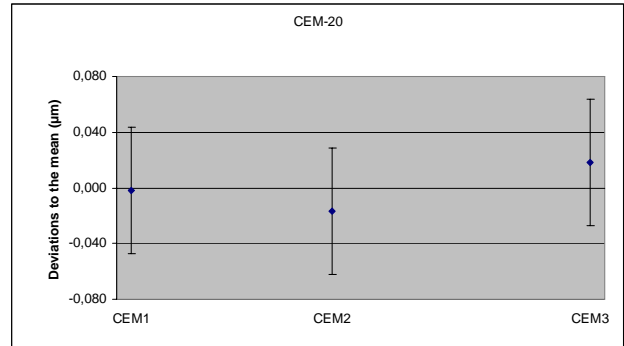

Gauge 1

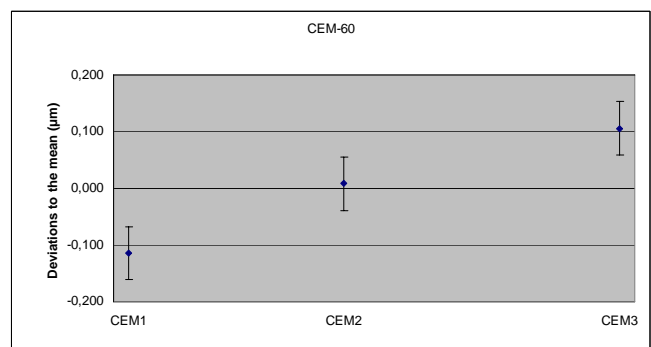
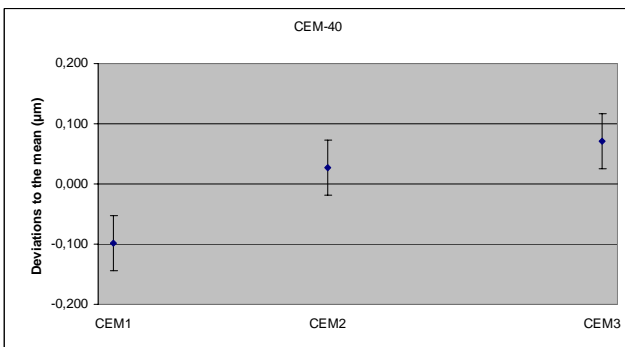

Gauge 2

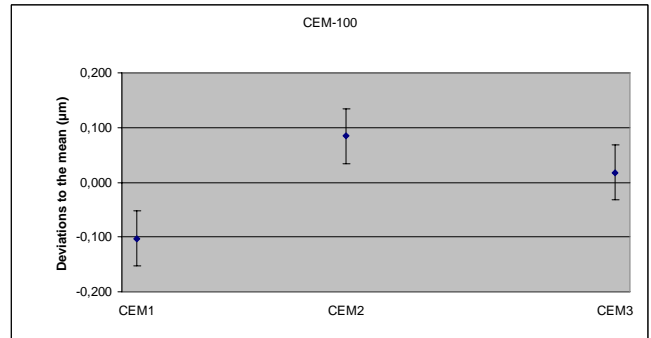
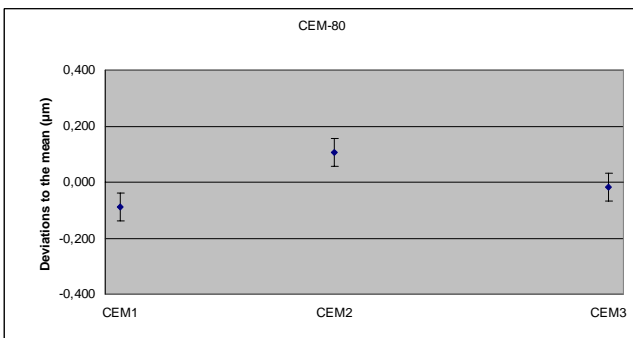

Gauge 3

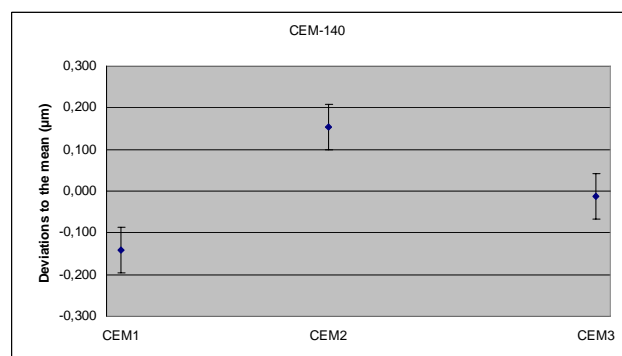
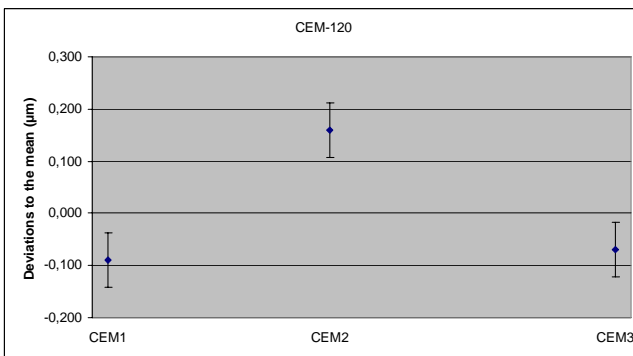

Gauge 4

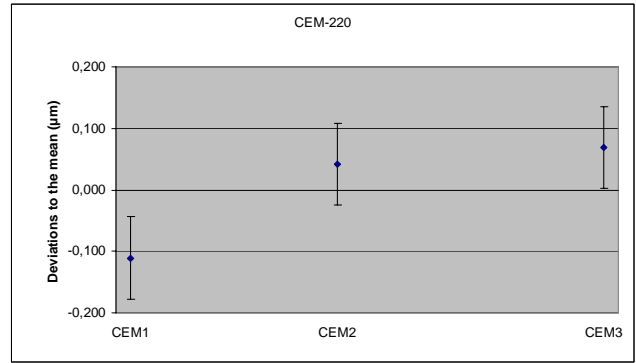
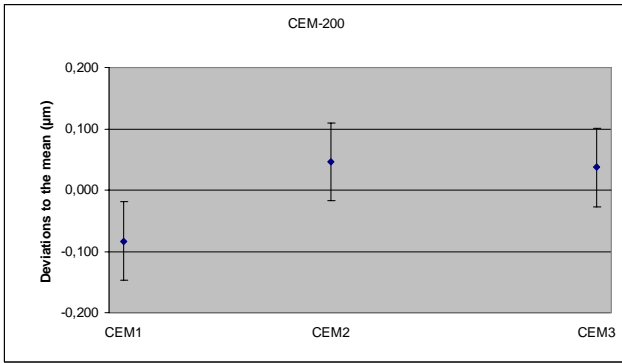

Gauge 6

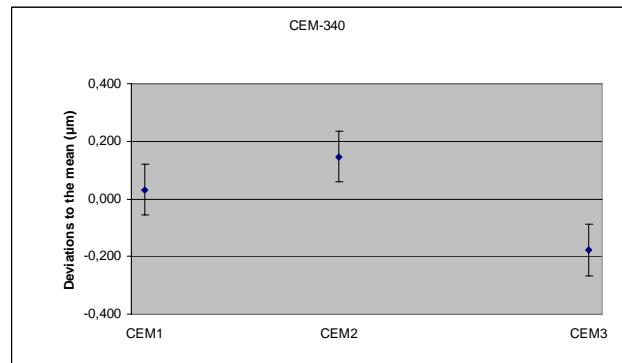
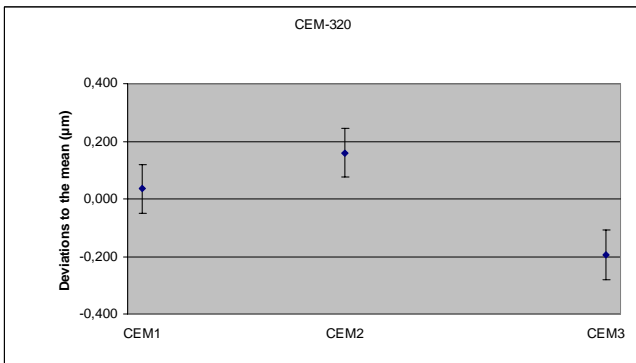

Gauge 9

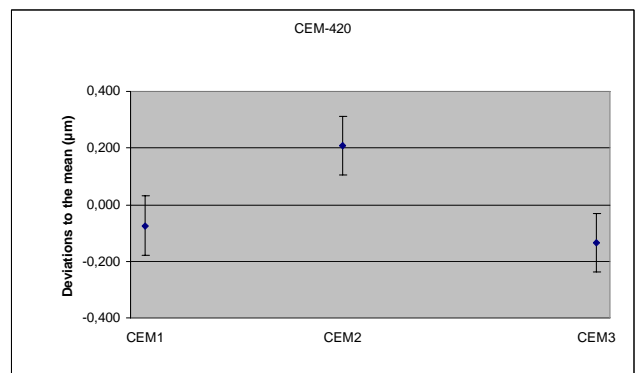
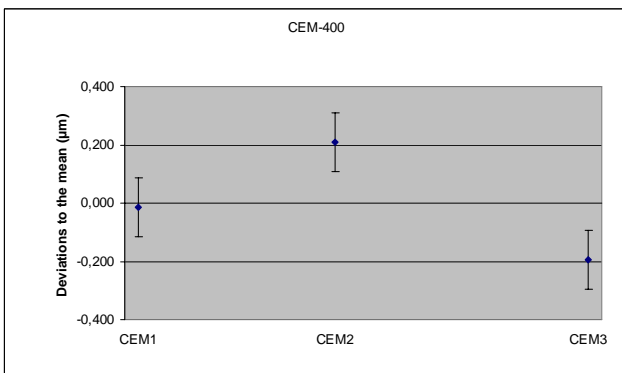

Gauge 11

Due to the significant instability of the step, an artefact uncertainty is considered. Such uncertainty is obtained by the standard deviation of the three measurements at the pilot laboratory, taking out the own uncertainty of CEM; i. e.: $u_{step} = (s_{mean}^2 - u_{pilot}^2)^{0.5}$, except for the 20 mm face, where the standard deviation is smaller than u_{pilot} and it was only considered s_{mean} . The resulting u_{step} values are as follows:

Gauge	1		2		3		4		6		9		11	
Face (mm)	20	40	60	80	100	120	140	200	220	320	340	400	420	
u_{step} (µm)	0.018	0.075	0.100	0.086	0.080	0.128	0.138	0.034	0.070	0.158	0.139	0.176	0.150	

u_{step} values should be the same for both faces of a particular gauge only in the case that the displacement of the gauge was pure; it is, the gauge suffering only a translation and not a rotation. But if the gauge has suffered a combination of translation and rotation, then the last one may combine with the poor flatness and parallelism of faces to produce different values on left and right faces.

Such effect of gauge rotation (pitch, yaw) may also combine with an expansion of gauges (temperature effects) and the repeatability of the CEM comparator, here including the compensation of the probe indication when touching right and left faces. Such repeatability is typically less than 40 nm and it is already considered within the uncertainty budget. As observed in the above table, the maximum discrepancy between faces takes place on gauge 6, with a difference of 36 nm.

As we are analyzing faces as different measurands to be compared against their nominal positions, we consider the values of the above table.

9.1 Weighting Factors and Reference Value

Let the number of participant laboratories L . Each laboratory reported a deviation from nominal position x_i per face and its associated standard uncertainty $u(x_i)$.

Thus, for any measured face, the normalised weight, w_i , for the result x_i is given by:

$$w_i = C \cdot \frac{1}{[u(x_i)]^2} \tag{1}$$

where the normalizing factor, C , is given by:

$$C = \frac{1}{\sum_{i=1}^L \left(\frac{1}{u(x_i)} \right)^2} \tag{2}$$

Then the (inverse-variance) weighted mean, \bar{x}_w , is given by:

$$\bar{x}_w = \sum_{i=1}^L w_i \cdot x_i \tag{3}$$

9.2 Uncertainties:

If the artefact was stable enough, its uncertainty would be ignored and the uncertainty of the reference value could be calculated as either the internal $u_{\text{int}}(\bar{x}_w)$ or external $u_{\text{ext}}(\bar{x}_w)$ standard deviation.

The internal standard deviation is based on the estimated uncertainties $u(x_i)$ as reported by the participants:

$$u_{\text{int}}(\bar{x}_w) = \sqrt{\frac{1}{\sum_{i=1}^L \left(\frac{1}{u(x_i)} \right)^2}} = \sqrt{C} \tag{4}$$

The external standard deviation is the standard deviation of the spread of differences $x_i - \bar{x}_w$, weighted by the uncertainties $u(x_i)$.

$$u_{ext}(\bar{x}_w) = \sqrt{\frac{1}{(L-1)} \cdot \frac{\sum_{i=1}^L w_i (x_i - \bar{x}_w)^2}{\sum_{i=1}^L w_i}} \quad (5)$$

Such differences have an uncertainty which results from the measured value [$x_i \pm u(x_i)$] and the reference value [$\bar{x}_w \pm u(\bar{x}_w)$]. The uncertainty of the reference value is taken to be the internal uncertainty plus the uncertainty of the artefact $u_{step}(\bar{x}_{RV})$. The internal uncertainty can be viewed as setting a limit to the knowable accuracy of any artefact's measured length, given by the uncertainty of each measurement.

The artefact uncertainty reflects the instability of the artefact during the comparison. This is why the Pilot's measurements provide the best information on the artefact changes, given that the same instrument and method were used each time. The uncertainty of the artefact is obtained by repeating the method used to determine the reference value, but only using the Pilot's data. **The standard deviation of the mean for just the Pilot's measurements, P , then gives the uncertainty for the step.**

$$u_{step}(\bar{x}_{pilot}) = \sqrt{\frac{\sum_{p=1}^P (x_p - \bar{x}_{pilot})^2}{P(P-1)}} \quad (6)$$

On this case, to reduce u_{step} , we took out the own uncertainty of the pilot, CEM; i. e.: $u_{step} = (s_{mean}^2 - u_{pilot}^2)^{0.5}$, except for the 20 mm face, where the standard deviation is smaller than u_{pilot} and it was only considered s_{mean} .

9.3 Analysis using E_N values

A check for statistical consistency of the results with their associated uncertainties can be made by calculating the E_N value for each laboratory, where E_N is defined as the ratio of the deviation from the weighted mean, divided by the uncertainty of this deviation, taken for a coverage factor of $k=2$:

$$E_N = \frac{x_i - \bar{x}_w}{2 \cdot u(x_i - \bar{x}_w)} \quad (7)$$

E_N values should be less than 1, if the participant's result and uncertainty are consistent with the reference value.

The uncertainty for each participant's difference with respect to the weighted mean is given by:

$$u(x_i - \bar{x}_w) = \sqrt{[u(x_i)]^2 - [u_{int}(\bar{x}_w)]^2 + [u_{step}(\bar{x}_{pilot})]^2} \quad (8)$$

where the internal uncertainty is subtracted from the participant's uncertainty because of correlation effects, since the participant's result contributes to the reference value. A plus sign should be used for values not contributing to the reference value.

In case a participant gets $E_N > 1$, it is excluded from the calculation of the reference value and its new E_N value is calculated as indicated above. Measurements with $E_N > 1$ have to be omitted one by one for the calculation of the reference value until all values contributing to the reference value fulfil $E_N \leq 1$.

9.4 Birge ratio test

The statistical consistency of a comparison can be investigated by the Birge ratio R_B , which compares the observed spread of the results with the spread expected from the individual reported uncertainties.

The application of least squares algorithms and the χ^2 -test leads to the Birge ratio:

$$R_B = \frac{u_{ext}(\bar{x}_w)}{u_{int}(\bar{x}_w)} \quad (9)$$

The Birge ratio has an expectation value of $R_B = 1$, when considering standard uncertainties. For a coverage factor of $k = 2$, the expectation value is increased and the data in a comparison are consistent provided that

$$R_B < \sqrt{1 + \sqrt{8/(L-1)}} \quad (10)$$

where L is the number of laboratories.

In our case, after taking the above indicated actions to save the comparison, $L = 18$ for gauges 1 and 9, and $L = 17$ for the rest of gauges to be analyzed (2, 3, 4, 6 and 11), because the exclusion of VNIIM.

So:

For gauges 1 and 9: $L = 18$ $R_B < 1.298$ indicates consistency.

For gauges 2, 3, 4, 6 and 11: $L = 17$ $R_B < 1.306$ indicates consistency.

For the calculation of the reference values only the pilot's value CEM2 is used (because it is towards the middle of the comparison). The results and uncertainties of the first (CEM1) and third (CEM3) measurements at the pilot laboratory aren't used, but they have effects on E_N values through the contribution to the uncertainty of the step.

9.5 Summary of results

- Deviations to nominal positions and standard uncertainties: $x_i \pm u(x_i)$ (μm)

Date	Lab.	Gauge 1		Gauge 2		Gauge 3		Gauge 4	
		20 mm	40 mm	60 mm	80 mm	100 mm	120 mm	140 mm	
Feb-05	BEV	1,391 ± 0,560	16,589 ± 0,502	17,903 ± 0,564	19,799 ± 0,508	20,456 ± 0,571	23,716 ± 0,518	24,142 ± 0,582	
Mar-05	NML	1,695 ± 1,100	16,636 ± 1,100	18,388 ± 1,100	19,557 ± 1,100	21,033 ± 1,100	23,247 ± 1,100	24,496 ± 1,100	
May-05	OMH	1,900 ± 0,441	16,600 ± 0,444	18,100 ± 0,448	19,800 ± 0,454	21,900 ± 0,462	24,100 ± 0,471	25,100 ± 0,482	
June-05	SP	1,522 ± 0,071	16,515 ± 0,073	17,942 ± 0,076	19,560 ± 0,078	20,621 ± 0,081	23,318 ± 0,084	24,253 ± 0,086	
July-05	CEM2	1,615 ± 0,045	16,437 ± 0,046	17,913 ± 0,047	19,615 ± 0,048	20,727 ± 0,050	23,488 ± 0,052	24,486 ± 0,055	
Sep-05	CGM	1,568 ± 0,200	16,493 ± 0,201	17,907 ± 0,201	19,521 ± 0,203	20,691 ± 0,204	23,366 ± 0,206	24,344 ± 0,208	
Oct-05	CMI	1,507 ± 0,150	16,543 ± 0,151	17,893 ± 0,153	19,609 ± 0,154	20,607 ± 0,157	23,406 ± 0,160	24,257 ± 0,163	
Nov-05	LNE	1,380 ± 0,167	16,740 ± 0,168	17,990 ± 0,172	19,840 ± 0,176	20,690 ± 0,181	23,690 ± 0,187	24,520 ± 0,194	
Dec-05	INM	0,790 ± 0,470	16,980 ± 0,472	17,750 ± 0,474	20,300 ± 0,477	20,470 ± 0,481	24,230 ± 0,485	24,400 ± 0,490	
Feb-06	INRIM	1,725 ± 0,100	16,635 ± 0,101	18,131 ± 0,102	19,623 ± 0,104	20,747 ± 0,106	23,391 ± 0,108	24,388 ± 0,111	
Mar-06	NPL	1,680 ± 0,050	16,690 ± 0,051	18,150 ± 0,052	19,740 ± 0,053	20,840 ± 0,054	23,490 ± 0,056	24,480 ± 0,058	
June-06	NRC	1,500 ± 0,110	16,592 ± 0,110	17,950 ± 0,111	19,591 ± 0,112	20,650 ± 0,113	23,433 ± 0,114	24,313 ± 0,115	
Aug-06	NMIA	1,660 ± 0,191	16,530 ± 0,192	18,160 ± 0,195	19,540 ± 0,199	20,910 ± 0,204	23,450 ± 0,209	24,540 ± 0,216	
Sep-06	VNIIM	1,300 ± 0,770	4,100 ± 0,771	7,300 ± 0,773	17,300 ± 0,776	19,600 ± 0,779	35,800 ± 0,783	37,600 ± 0,787	
Nov-06	MIKES	1,556 ± 0,077	16,723 ± 0,077	18,112 ± 0,077	19,752 ± 0,078	20,782 ± 0,078	23,595 ± 0,078	24,506 ± 0,079	
Dec-06	VSL	1,596 ± 0,076	16,703 ± 0,078	18,053 ± 0,082	19,654 ± 0,087	20,699 ± 0,094	23,466 ± 0,101	24,396 ± 0,109	
Feb-07	GUM	1,500 ± 0,410	16,400 ± 0,411	18,100 ± 0,411	19,300 ± 0,412	21,300 ± 0,413	23,100 ± 0,415	24,700 ± 0,417	
Apr-07	INMETRO	1,720 ± 0,151	16,590 ± 0,151	18,050 ± 0,152	19,670 ± 0,154	20,740 ± 0,156	23,490 ± 0,158	24,350 ± 0,161	

Date	Lab.	Gauge 6		Gauge 9		Gauge 11	
		200 mm	220 mm	320 mm	340 mm	400 mm	420 mm
Feb-05	BEV	43,697 ± 0,550	44,035 ± 0,614	75,402 ± 0,619	76,481 ± 0,681	91,550 ± 0,677	92,192 ± 0,737
Mar-05	NML	43,200 ± 1,100	44,795 ± 1,100	75,058 ± 1,200	77,343 ± 1,200	91,867 ± 1,200	93,215 ± 1,200
May-05	OMH	43,800 ± 0,522	44,800 ± 0,537	75,600 ± 0,628	77,200 ± 0,648	92,200 ± 0,712	93,000 ± 0,734
June-05	SP	43,626 ± 0,094	44,541 ± 0,097	75,505 ± 0,110	77,034 ± 0,112	92,000 ± 0,120	92,967 ± 0,123
July-05	CEM2	43,699 ± 0,064	44,693 ± 0,067	75,493 ± 0,085	77,095 ± 0,089	91,994 ± 0,101	93,053 ± 0,105
Sep-05	CGM	43,587 ± 0,215	44,549 ± 0,219	75,317 ± 0,237	76,893 ± 0,242	92,007 ± 0,256	92,869 ± 0,261
Oct-05	CMI	43,688 ± 0,176	44,539 ± 0,181	75,516 ± 0,210	76,989 ± 0,217	92,061 ± 0,237	93,059 ± 0,245
Nov-05	LNE	43,980 ± 0,220	44,840 ± 0,229	75,710 ± 0,284	77,050 ± 0,296	92,270 ± 0,332	93,270 ± 0,345
Dec-05	INM	44,380 ± 0,511	44,680 ± 0,519	75,600 ± 0,569	76,460 ± 0,580	92,670 ± 0,617	92,790 ± 0,630
Feb-06	INRIM	43,768 ± 0,122	44,739 ± 0,126	75,219 ± 0,150	76,822 ± 0,155	91,653 ± 0,172	92,791 ± 0,178
Mar-06	NPL	43,870 ± 0,065	44,800 ± 0,068	75,330 ± 0,083	76,910 ± 0,086	91,900 ± 0,097	92,940 ± 0,100
June-06	NRC	43,790 ± 0,120	44,685 ± 0,122	75,272 ± 0,134	76,754 ± 0,137	91,853 ± 0,146	92,749 ± 0,149
Aug-06	NMIA	43,900 ± 0,240	44,950 ± 0,249	75,530 ± 0,301	77,150 ± 0,313	91,980 ± 0,348	93,120 ± 0,361
Sep-06	VNIIM	51,000 ± 0,805	52,200 ± 0,812	75,100 ± 0,856	78,200 ± 0,867	95,100 ± 0,901	94,700 ± 0,914
Nov-06	MIKES	43,818 ± 0,081	44,761 ± 0,082	75,262 ± 0,087	76,768 ± 0,088	91,847 ± 0,092	92,816 ± 0,093
Dec-06	VSL	43,673 ± 0,135	44,564 ± 0,144	75,100 ± 0,194	76,617 ± 0,205	91,677 ± 0,236	92,664 ± 0,247
Feb-07	GUM	44,500 ± 0,423	45,400 ± 0,426	76,300 ± 0,444	77,700 ± 0,448	91,300 ± 0,462	92,900 ± 0,467
Apr-07	INMETRO	44,310 ± 0,170	45,190 ± 0,174	75,820 ± 0,198	77,310 ± 0,203	91,780 ± 0,220	92,810 ± 0,226

Figures in red and shaded data: Values not considered in the calculation of the reference value, X_w , because causing $E_N > 1$

- Uncertainty due to the step instability: u_{step} (μm)

	Gauge 1	Gauge 2		Gauge 3		Gauge 4		Gauge 6		Gauge 9		Gauge 11	
	20 mm	40 mm	60 mm	80 mm	100 mm	120 mm	140 mm	200 mm	220 mm	320 mm	340 mm	400 mm	420 mm
u_{step}	0.018	0.075	0.100	0.086	0.080	0.128	0.138	0.034	0.070	0.158	0.139	0.176	0.150

- Reference Value: Weighted mean (x_w) and its uncertainty $u(x_w)$ (μm)

	Gauge 1	Gauge 2		Gauge 3		Gauge 4		Gauge 6		Gauge 9		Gauge 11	
x_w	1,605	16,577	18,014	19,657	20,741	23,490	24,448	43,780	44,720	75,390	76,933	91,908	92,909
$u(x_w)$	0,024	0,024	0,024	0,025	0,026	0,026	0,027	0,031	0,032	0,037	0,038	0,042	0,043

- E_N values

Date	Lab.	Gauge 1	Gauge 2		Gauge 3		Gauge 4		Gauge 6		Gauge 9		Gauge 11	
		20 mm	40 mm	60 mm	80 mm	100 mm	120 mm	140 mm	200 mm	220 mm	320 mm	340 mm	400 mm	420 mm
Feb-05	BEV	-0,19	0,01	-0,10	0,14	-0,25	0,21	-0,26	-0,08	-0,56	0,01	-0,33	-0,26	-0,48
Mar-05	NML	0,04	0,03	0,17	-0,05	0,13	-0,11	0,02	-0,26	0,03	-0,14	0,17	-0,02	0,13
May-05	OMH	0,33	0,03	0,09	0,16	1,23	0,63	0,65	0,02	0,07	0,16	0,20	0,20	0,06
June-05	SP	-0,60	-0,30	-0,29	-0,43	-0,54	-0,57	-0,61	-0,81	-0,78	0,31	0,29	0,22	0,15
July-05	CEM2	0,11	-0,82	-0,47	-0,22	-0,08	0,00	0,13	-0,62	-0,15	0,30	0,51	0,22	0,40
Sep-05	CGM	-0,09	-0,20	-0,24	-0,31	-0,12	-0,26	-0,21	-0,45	-0,38	-0,13	-0,07	0,16	-0,07
Oct-05	CMI	-0,33	-0,10	-0,33	-0,14	-0,39	-0,21	-0,45	-0,26	-0,47	0,24	0,11	0,26	0,26
Nov-05	LNE	-0,68	0,45	-0,06	0,47	-0,13	0,45	0,15	0,45	0,25	0,50	0,18	0,48	0,48
Dec-05	INM	-0,87	0,42	-0,27	0,67	-0,28	0,74	-0,05	0,59	-0,04	0,18	-0,40	0,60	-0,09
Feb-06	INRIM	0,61	0,24	0,42	-0,13	0,02	-0,30	-0,17	-0,05	0,07	-0,40	-0,27	-0,53	-0,26
Mar-06	NPL	0,78	0,65	0,62	0,43	0,53	0,00	0,11	0,68	0,43	-0,17	-0,07	-0,02	0,09
June-06	NRC	-0,49	0,06	-0,22	-0,24	-0,33	-0,17	-0,38	0,04	-0,13	-0,29	-0,47	-0,12	-0,39
Aug-06	NMIA	0,14	-0,11	0,34	-0,27	0,39	-0,08	0,18	0,25	0,45	0,21	0,32	0,09	0,27
Sep-06	VNIIM	-0,20	-8,05	-6,87	-1,51	-0,73	7,77	8,23	4,49	4,59	-0,17	0,72	1,74	0,97
Nov-06	MIKES	-0,33	0,69	0,40	0,42	0,18	0,36	0,18	0,24	0,20	-0,36	-0,51	-0,16	-0,27
Dec-06	VSL	-0,07	0,60	0,15	-0,01	-0,18	-0,07	-0,15	-0,39	-0,50	-0,58	-0,65	-0,40	-0,43
Feb-07	GUM	-0,13	-0,21	0,10	-0,42	0,66	-0,45	0,29	0,85	0,79	0,97	0,82	-0,62	-0,01
Apr-07	INMETRO	0,38	0,04	0,10	0,04	0,00	0,00	-0,23	1,51	1,23	0,86	0,78	-0,23	-0,18

From the 234 values, 221 (94.4 %) are less than 1. This comply with the expectation of 95 % of the results being within the stated uncertainties, at $k = 2$. By excluding VNIIM results in gauges 2, 3, 4, 6 & 11, such percentage raises 98.7 % (221/224).

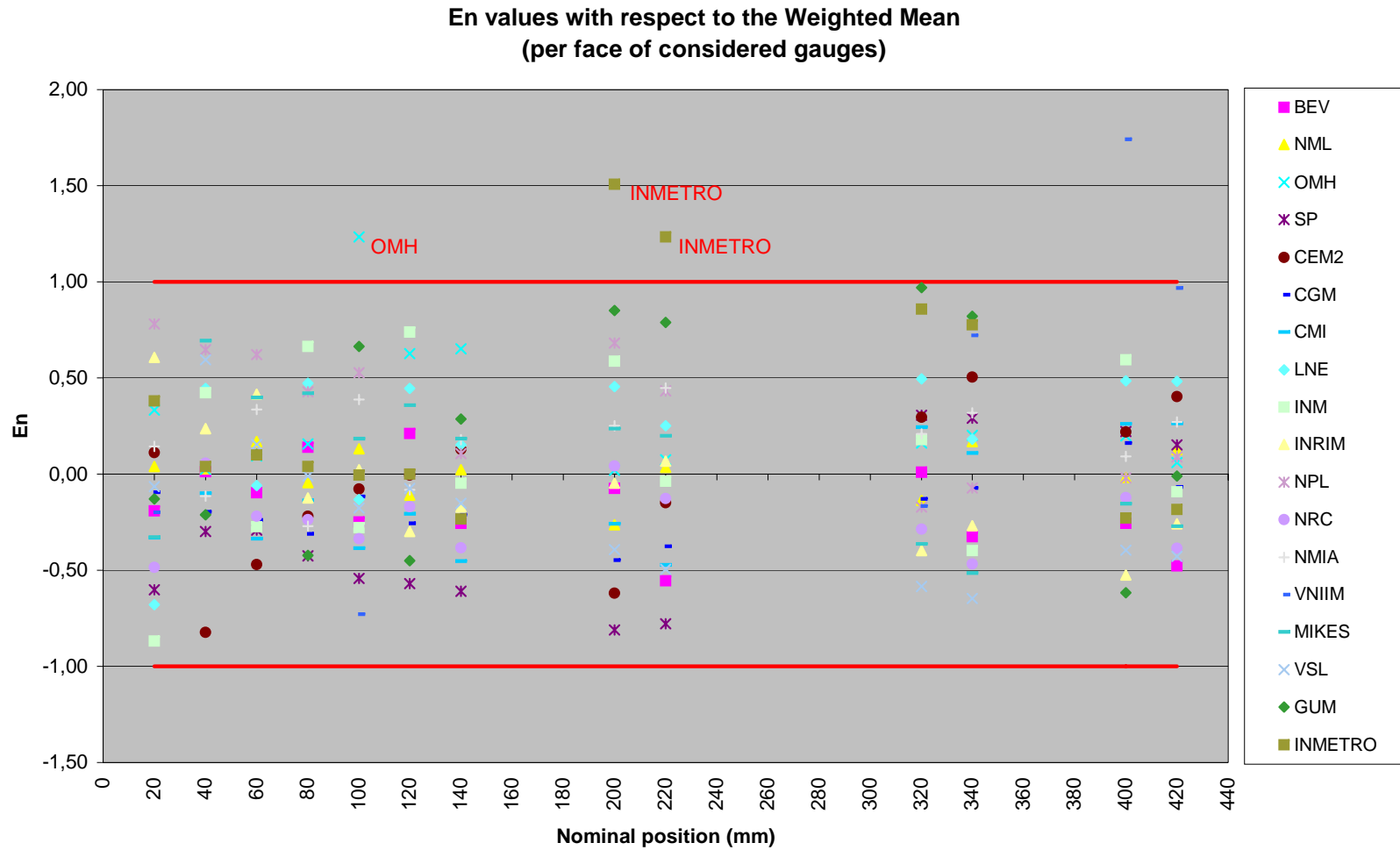

VNIIM results represented only for gauges 1 and 9.

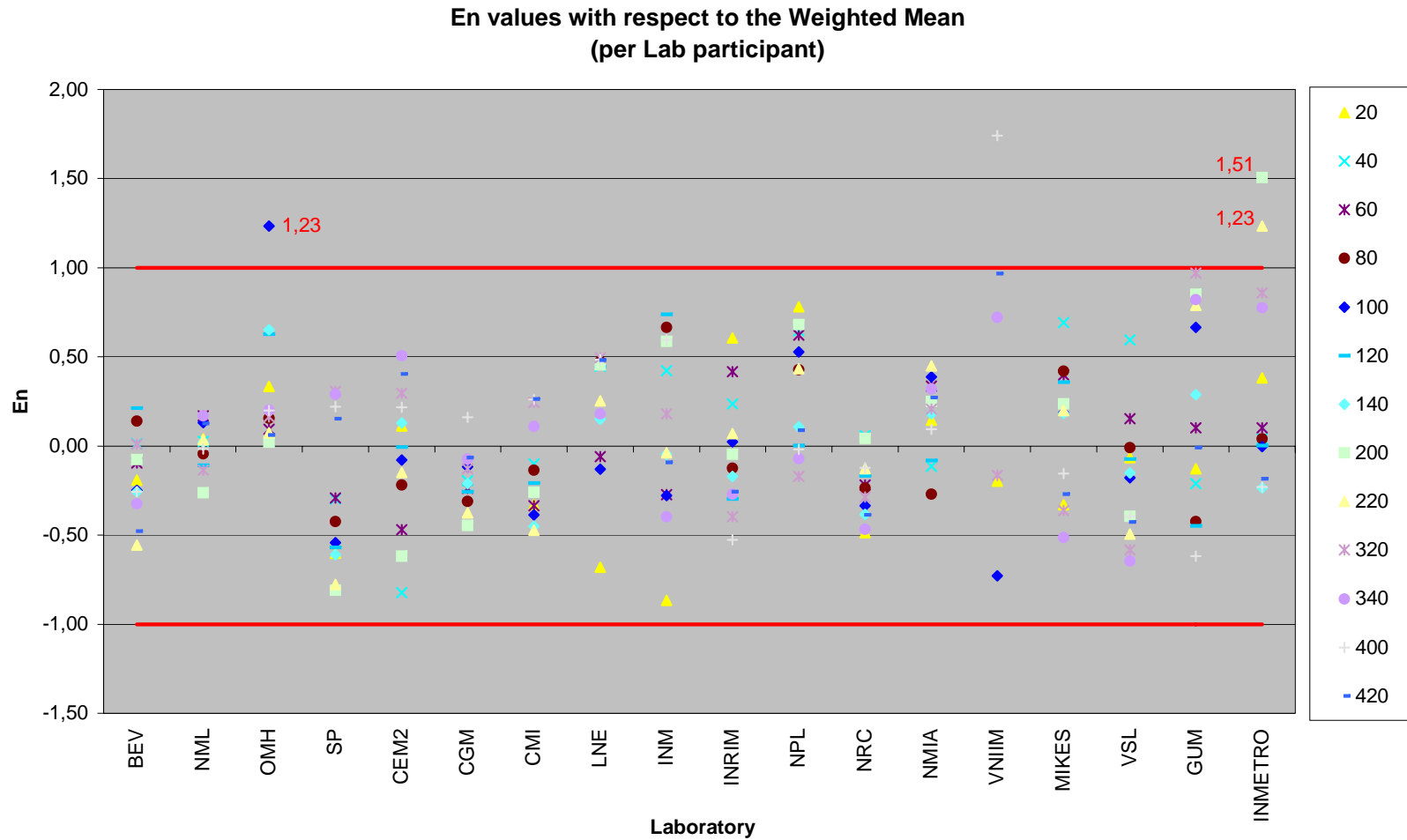

VNIIM results represented only for gauges 1 and 9.

- Birge Ratio

Consistency if BR		< 1,298	< 1,306	< 1,306	< 1,306	< 1,306	< 1,306	< 1,306	< 1,306	< 1,298	< 1,298	< 1,306	< 1,306	
		Gauge 1	Gauge 2		Gauge 3		Gauge 4		Gauge 6		Gauge 9		Gauge 11	
Date	Lab.	20 mm	40 mm	60 mm	80 mm	100 mm	120 mm	140 mm	200 mm	220 mm	320 mm	340 mm	400 mm	420 mm
Feb-05	BEV	0,093	0,006	0,049	0,070	0,127	0,109	0,131	0,045	0,285	0,005	0,161	0,132	0,243
Mar-05	NML	0,020	0,013	0,085	0,023	0,065	0,055	0,011	0,136	0,014	0,067	0,083	0,008	0,064
May-05	OMH	0,162	0,013	0,048	0,079	0,625	0,324	0,338	0,002	0,030	0,081	0,100	0,103	0,031
June-05	SP	0,285	0,209	0,236	0,308	0,384	0,513	0,568	0,455	0,503	0,255	0,219	0,193	0,118
July-05	CEM2	0,051	0,762	0,538	0,215	0,089	0,006	0,171	0,383	0,160	0,297	0,444	0,215	0,344
Sep-05	CGM	0,045	0,104	0,132	0,168	0,067	0,150	0,126	0,244	0,214	0,074	0,040	0,097	0,038
Oct-05	CMI	0,159	0,055	0,198	0,077	0,220	0,131	0,293	0,154	0,272	0,146	0,063	0,161	0,153
Nov-05	LNE	0,328	0,243	0,035	0,261	0,076	0,268	0,092	0,209	0,114	0,274	0,096	0,272	0,262
Dec-05	INM	0,420	0,214	0,139	0,337	0,143	0,382	0,025	0,286	0,027	0,090	0,198	0,309	0,047
Feb-06	INRIM	0,290	0,145	0,287	0,080	0,005	0,228	0,135	0,058	0,008	0,275	0,173	0,370	0,166
Mar-06	NPL	0,360	0,560	0,661	0,396	0,439	0,001	0,136	0,283	0,239	0,174	0,064	0,020	0,078
June-06	NRC	0,233	0,035	0,145	0,146	0,210	0,125	0,295	0,014	0,102	0,212	0,317	0,093	0,269
Aug-06	NMIA	0,069	0,061	0,188	0,147	0,203	0,047	0,106	0,108	0,216	0,113	0,168	0,052	0,146
Sep-06	VNIIM	0,096	3,923	3,361	0,737	0,357	3,815	4,052	2,171	2,230	0,082	0,355	0,859	0,476
Nov-06	MIKES	0,156	0,473	0,319	0,306	0,117	0,335	0,182	0,067	0,078	0,357	0,453	0,164	0,249
Dec-06	VSL	0,031	0,403	0,119	0,006	0,124	0,060	0,122	0,229	0,296	0,361	0,374	0,244	0,248
Feb-07	GUM	0,062	0,108	0,052	0,216	0,336	0,235	0,151	0,415	0,390	0,498	0,415	0,329	0,005
Apr-07	INMETRO	0,184	0,022	0,060	0,022	0,008	0,000	0,153	0,755	0,653	0,527	0,451	0,145	0,109

VNIIM was excluded, as outlier, for gauges 2, 3, 4, 6 and 11, before establishing the consistency value for the Birge Ratio. After excluding VNIIM, all values are lower, by far, than the consistency limits.

- Degrees of Equivalence: Deviations to the weighted mean and expanded uncertainties of such deviations: $(x_i - x_w) \pm U(x_i - x_w)$ (μm)

Date	Lab.	Gauge 1	Gauge 2		Gauge 3		Gauge 4	
		20 mm	40 mm	60 mm	80 mm	100 mm	120 mm	140 mm
Feb-05	BEV	-0,209 ± 1,120	0,002 ± 1,014	-0,116 ± 1,145	0,139 ± 1,030	-0,287 ± 1,153	0,236 ± 1,066	-0,292 ± 1,196
Mar-05	NML	0,095 ± 2,200	0,049 ± 2,205	0,368 ± 2,208	-0,104 ± 2,206	0,290 ± 2,205	-0,232 ± 2,214	0,061 ± 2,217
May-05	OMH	0,300 ± 0,881	0,014 ± 0,899	0,081 ± 0,917	0,139 ± 0,923	1,158 ± 0,939	0,620 ± 0,975	0,665 ± 1,001
June-05	SP	-0,078 ± 0,138	-0,071 ± 0,205	-0,077 ± 0,246	-0,101 ± 0,227	-0,122 ± 0,222	-0,161 ± 0,301	-0,182 ± 0,320
July-05	CEM2	0,015 ± 0,085	-0,150 ± 0,170	-0,107 ± 0,215	-0,046 ± 0,191	-0,015 ± 0,183	0,009 ± 0,271	0,051 ± 0,292
Sep-05	CGM	-0,032 ± 0,399	-0,093 ± 0,426	-0,112 ± 0,447	-0,140 ± 0,437	-0,052 ± 0,435	-0,114 ± 0,481	-0,091 ± 0,495
Oct-05	CMI	-0,093 ± 0,299	-0,043 ± 0,334	-0,127 ± 0,361	-0,052 ± 0,350	-0,135 ± 0,349	-0,074 ± 0,406	-0,178 ± 0,424
Nov-05	LNE	-0,220 ± 0,332	0,154 ± 0,366	-0,029 ± 0,394	0,179 ± 0,388	-0,052 ± 0,393	0,210 ± 0,450	0,085 ± 0,473
Dec-05	INM	-0,810 ± 0,940	0,394 ± 0,954	-0,269 ± 0,967	0,639 ± 0,968	-0,272 ± 0,973	0,750 ± 1,002	-0,035 ± 1,017
Feb-06	INRIM	0,125 ± 0,198	0,049 ± 0,248	0,111 ± 0,281	-0,037 ± 0,265	0,005 ± 0,261	-0,089 ± 0,331	-0,046 ± 0,350
Mar-06	NPL	0,080 ± 0,095	0,104 ± 0,175	0,131 ± 0,219	0,079 ± 0,195	0,098 ± 0,187	0,010 ± 0,274	0,045 ± 0,294
June-06	NRC	-0,100 ± 0,218	0,005 ± 0,263	-0,070 ± 0,294	-0,069 ± 0,277	-0,092 ± 0,272	-0,047 ± 0,338	-0,122 ± 0,355
Aug-06	NMIA	0,060 ± 0,380	-0,056 ± 0,410	0,141 ± 0,435	-0,121 ± 0,430	0,168 ± 0,435	-0,030 ± 0,487	0,105 ± 0,509
Sep-06	VNIIM	-0,300 ± 1,540	-12,474 ± 1,549	-10,708 ± 1,558	-2,358 ± 1,560	-1,141 ± 1,565	12,306 ± 1,585	13,149 ± 1,597
Nov-06	MIKES	-0,044 ± 0,151	0,136 ± 0,211	0,093 ± 0,248	0,091 ± 0,226	0,039 ± 0,218	0,115 ± 0,295	0,071 ± 0,313
Dec-06	VSL	-0,004 ± 0,148	0,116 ± 0,212	0,033 ± 0,254	-0,006 ± 0,240	-0,044 ± 0,241	-0,014 ± 0,321	-0,039 ± 0,347
Feb-07	GUM	-0,100 ± 0,820	-0,186 ± 0,833	0,081 ± 0,845	-0,361 ± 0,841	0,558 ± 0,841	-0,380 ± 0,867	0,265 ± 0,876
Apr-07	INMETRO	0,120 ± 0,300	0,004 ± 0,334	0,031 ± 0,360	0,009 ± 0,349	-0,002 ± 0,347	0,010 ± 0,403	-0,085 ± 0,420

Date	Lab.	Gauge 6		Gauge 9		Gauge 11	
		200 mm	220 mm	320 mm	340 mm	400 mm	420 mm
Feb-05	BEV	-0,072 ± 1,099	-0,672 ± 1,234	0,005 ± 1,275	-0,457 ± 1,388	-0,363 ± 1,396	-0,718 ± 1,502
Mar-05	NML	-0,569 ± 2,200	0,088 ± 2,204	-0,340 ± 2,420	0,405 ± 2,415	-0,045 ± 2,424	0,305 ± 2,417
May-05	OMH	0,031 ± 1,043	0,093 ± 1,081	0,202 ± 1,293	0,262 ± 1,324	0,287 ± 1,465	0,090 ± 1,497
June-05	SP	-0,143 ± 0,190	-0,166 ± 0,230	0,107 ± 0,377	0,096 ± 0,349	0,088 ± 0,418	0,056 ± 0,379
July-05	CEM2	-0,070 ± 0,130	-0,014 ± 0,183	0,096 ± 0,351	0,157 ± 0,321	0,082 ± 0,397	0,143 ± 0,356
Sep-05	CGM	-0,182 ± 0,432	-0,158 ± 0,455	-0,081 ± 0,566	-0,046 ± 0,553	0,095 ± 0,616	-0,041 ± 0,597
Oct-05	CMI	-0,081 ± 0,353	-0,168 ± 0,383	0,119 ± 0,521	0,051 ± 0,509	0,148 ± 0,585	0,149 ± 0,568
Nov-05	LNE	0,211 ± 0,440	0,133 ± 0,476	0,312 ± 0,646	0,112 ± 0,649	0,357 ± 0,748	0,360 ± 0,748
Dec-05	INM	0,611 ± 1,022	-0,027 ± 1,045	0,202 ± 1,178	-0,478 ± 1,191	0,757 ± 1,281	-0,120 ± 1,293
Feb-06	INRIM	-0,001 ± 0,246	0,032 ± 0,282	-0,179 ± 0,430	-0,116 ± 0,410	-0,260 ± 0,485	-0,119 ± 0,458
Mar-06	NPL	0,101 ± 0,133	0,093 ± 0,184	-0,068 ± 0,349	-0,028 ± 0,318	-0,013 ± 0,393	0,030 ± 0,351
June-06	NRC	0,021 ± 0,242	-0,022 ± 0,274	-0,126 ± 0,408	-0,185 ± 0,383	-0,059 ± 0,450	-0,162 ± 0,415
Aug-06	NMIA	0,131 ± 0,480	0,243 ± 0,513	0,132 ± 0,676	0,212 ± 0,680	0,067 ± 0,776	0,210 ± 0,777
Sep-06	VNIIM	7,220 ± 1,610	7,481 ± 1,629	-0,298 ± 1,740	1,262 ± 1,754	3,180 ± 1,834	1,786 ± 1,850
Nov-06	MIKES	0,049 ± 0,164	0,054 ± 0,206	-0,136 ± 0,353	-0,170 ± 0,320	-0,065 ± 0,388	-0,094 ± 0,344
Dec-06	VSL	-0,096 ± 0,271	-0,143 ± 0,315	-0,298 ± 0,495	-0,321 ± 0,489	-0,236 ± 0,583	-0,246 ± 0,572
Feb-07	GUM	0,731 ± 0,847	0,693 ± 0,862	0,902 ± 0,939	0,762 ± 0,935	-0,613 ± 0,984	-0,010 ± 0,977
Apr-07	INMETRO	0,541 ± 0,352	0,483 ± 0,381	0,422 ± 0,501	0,372 ± 0,486	-0,133 ± 0,557	-0,100 ± 0,536

Figures in red correspond to those values not considered in the calculation of the reference value (X_w)

- Graph showing the dispersion of Deviations to the weighted mean:

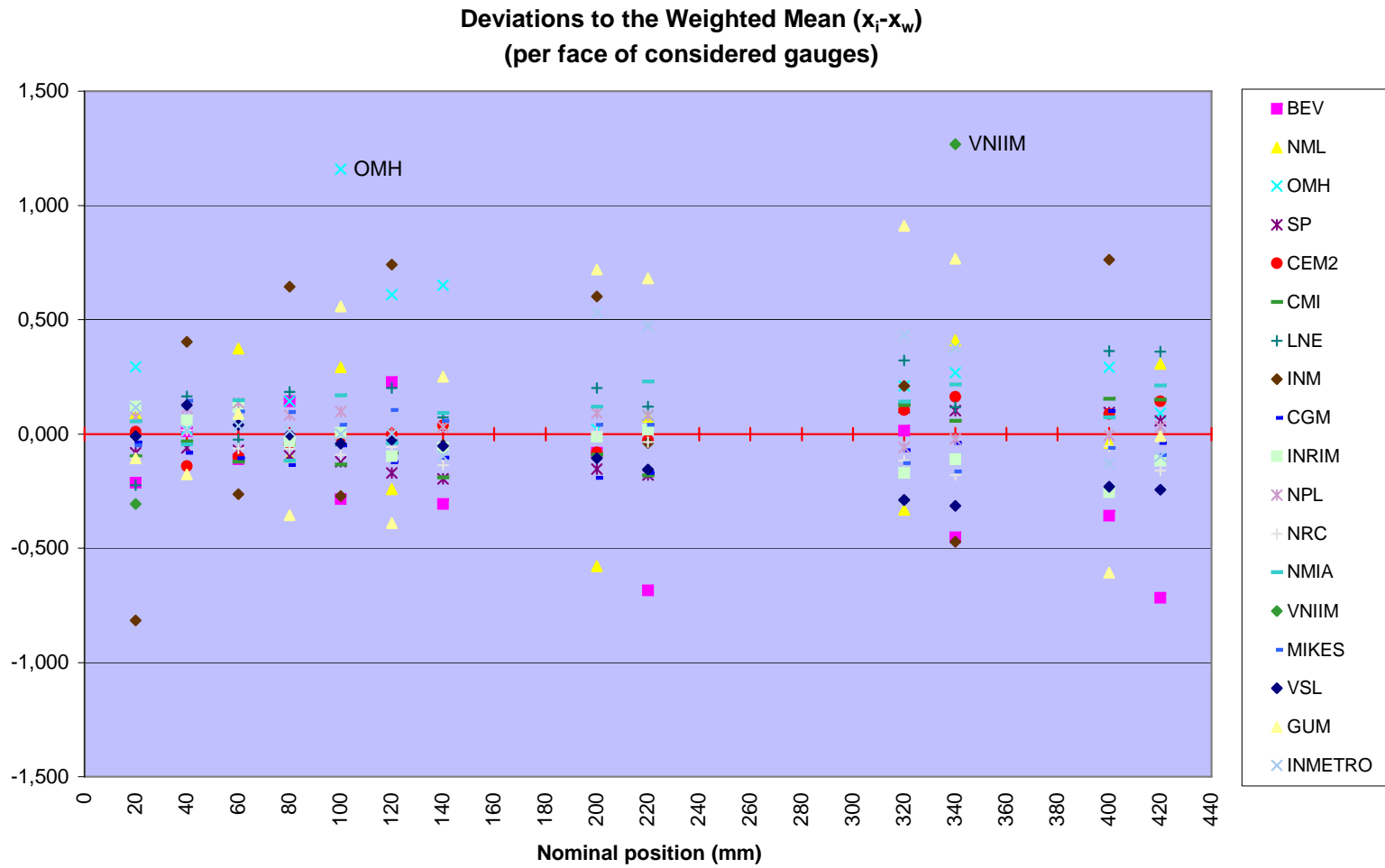

VNIIM results represented only for gauges 1 and 9.

- Graphs showing the unilateral Degrees of Equivalence: $(x_i - x_w) \pm U(x_i - x_w)$ (μm)

VNIIM results represented only for gauges 1 and 9.

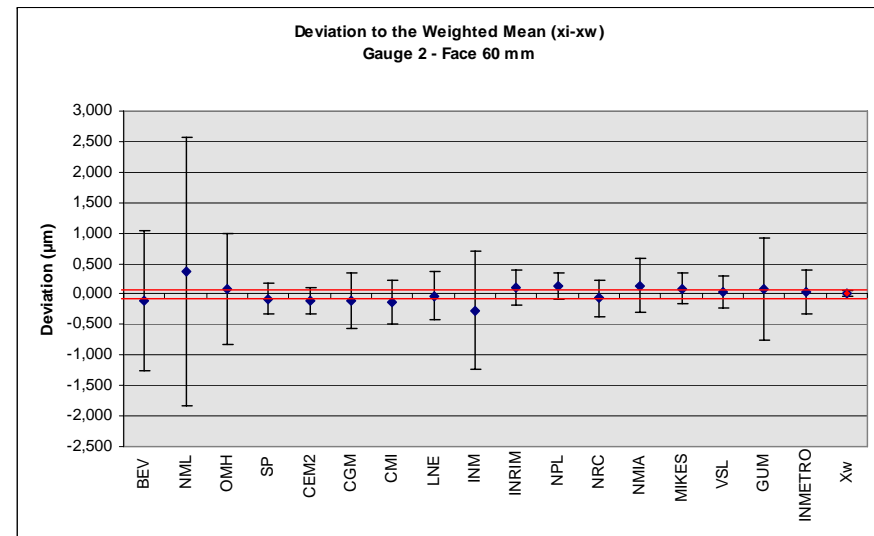
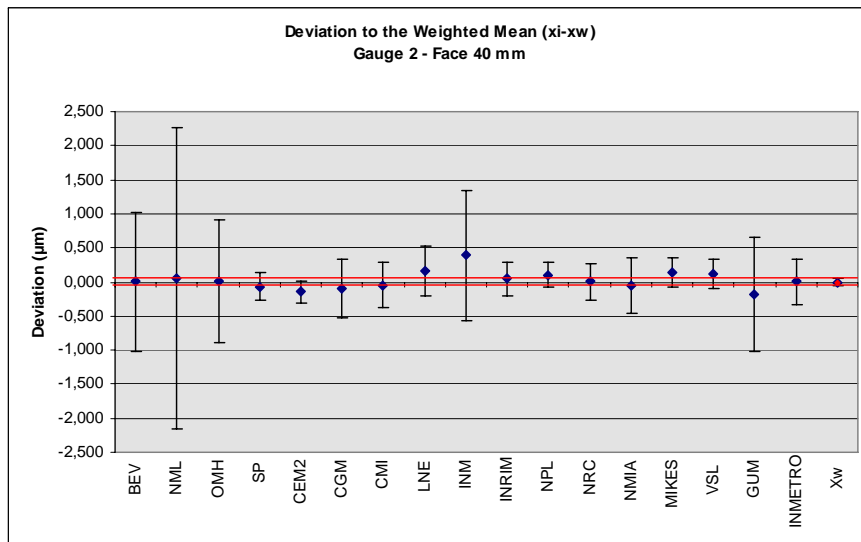
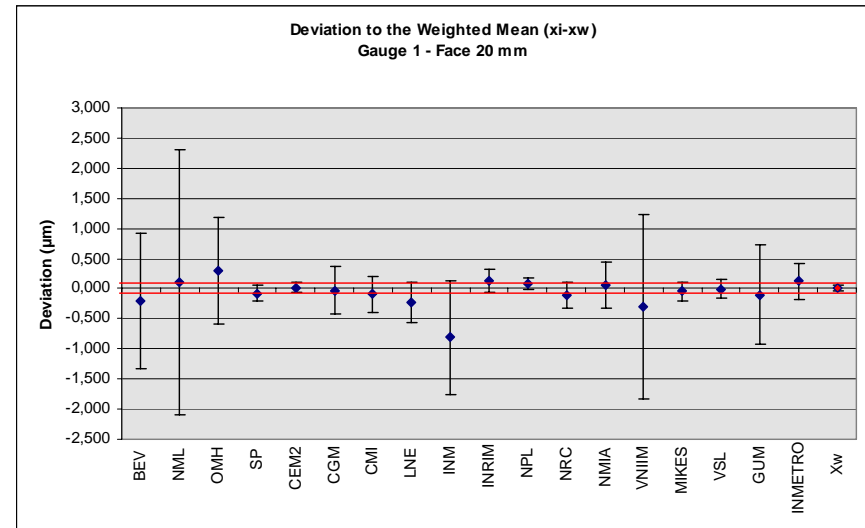

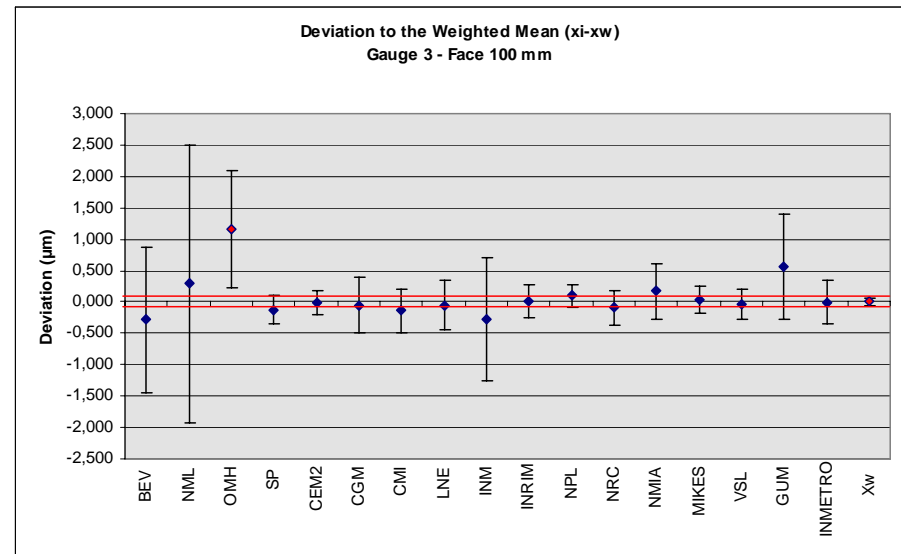
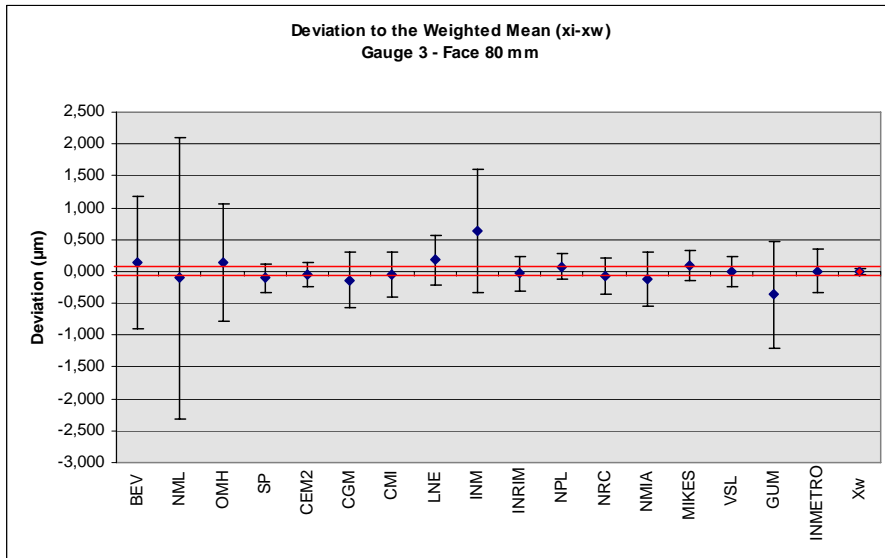

OMH outlier ($E_N > 1$) not contributing to the reference value.

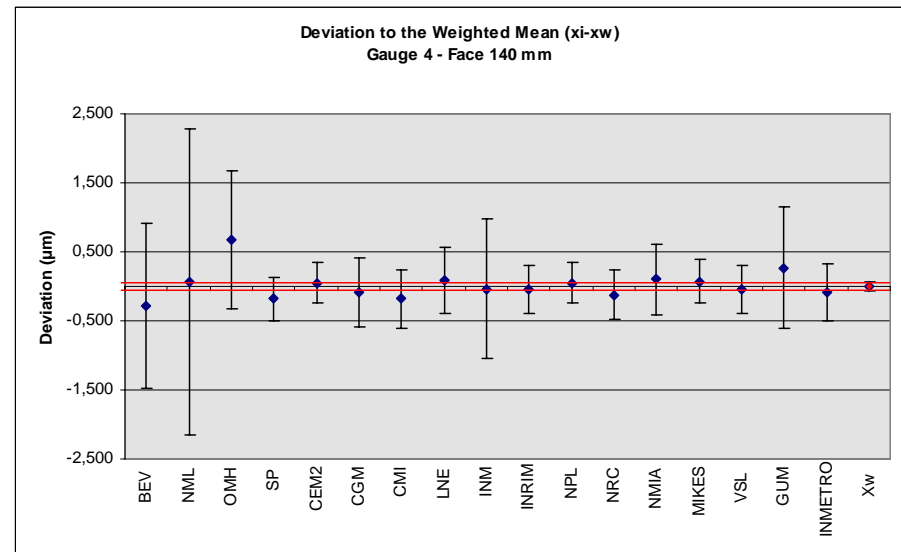
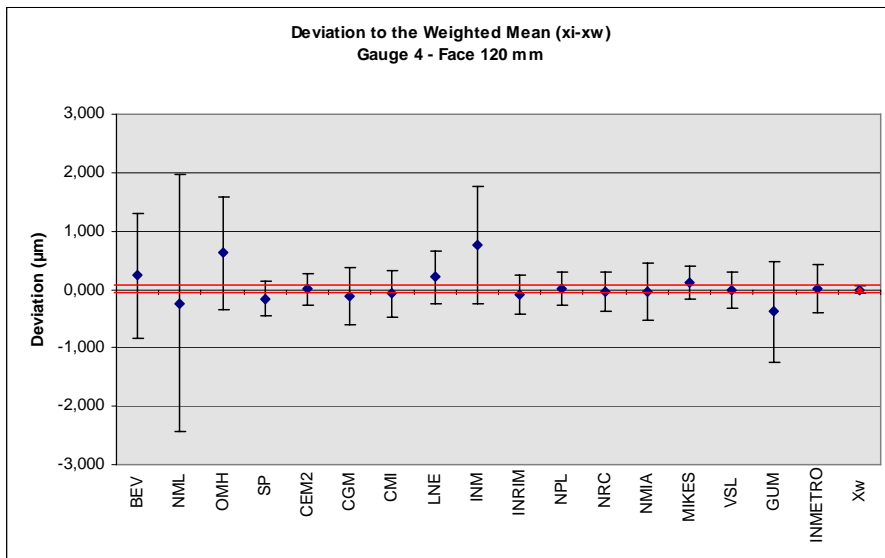

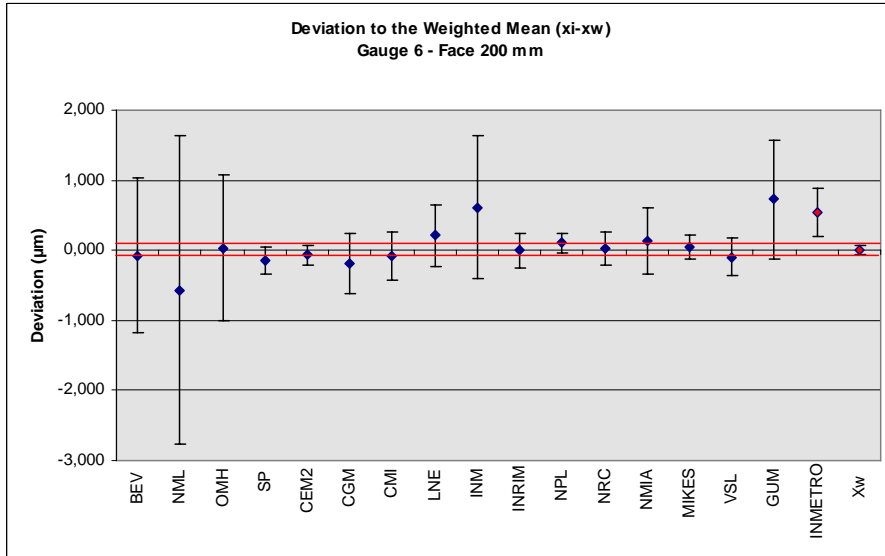

INMETRO outlier ($E_N > 1$) not contributing to the reference value.

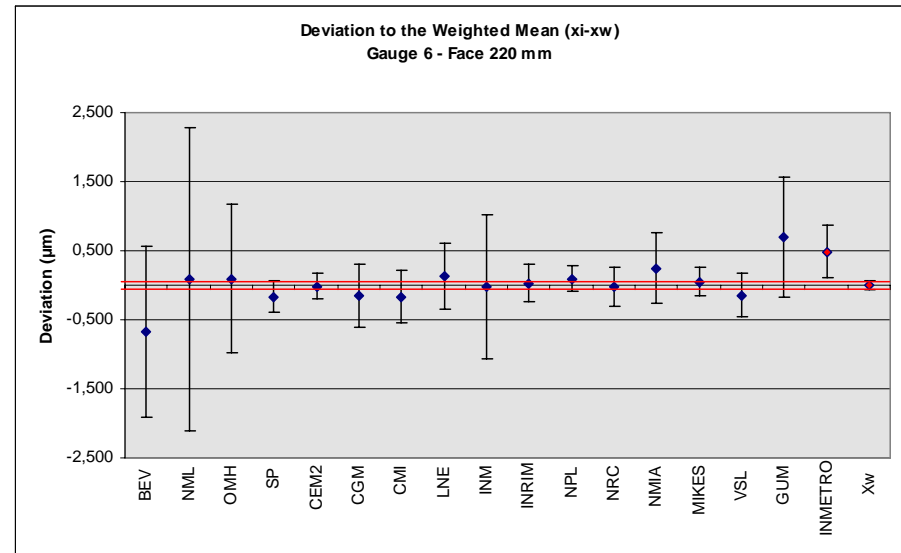

INMETRO outlier ($E_N > 1$) not contributing to the reference value.

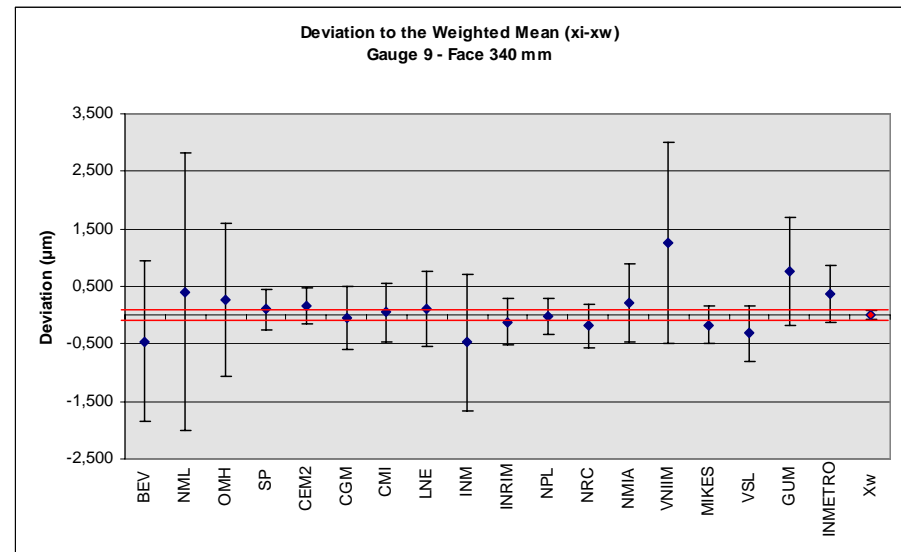
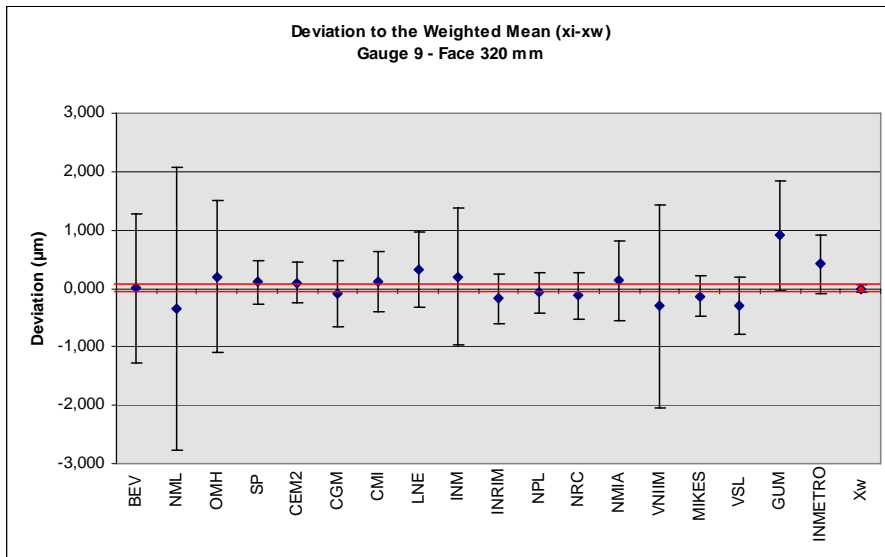

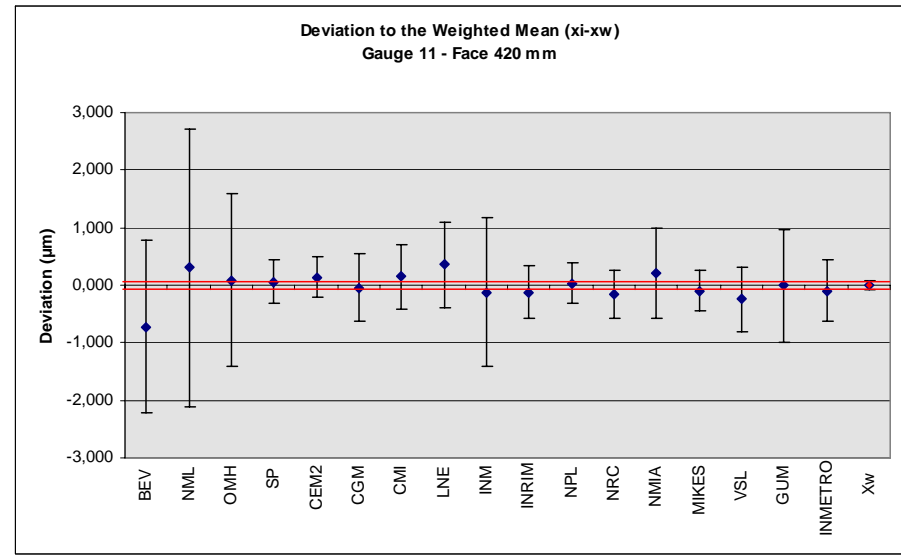
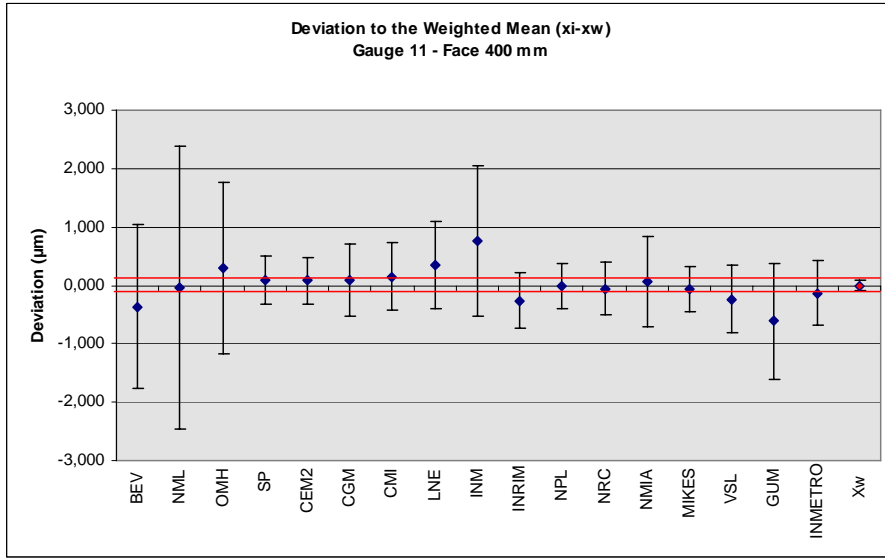

10 Second Group: CENAM-CEM4

The reason to separate the comparison in two has been the strange behaviour observed on the step gauge between April 2007 and September 2007, just after INMETRO measurements, conducting to CENAM and CEM4 obtaining very different results to everybody else.

So, we analyze here the measurements realized by CENAM and the pilot (CEM4) at the end of the comparison on gauges 1, 2, 3, 4, 6, 9 and 11, those whose ‘a priori’ supposed stability has been verified through the main group results. So, taking CEM4 as linking lab. it is the only way to get conclusions on the capability of CENAM to realize this type of calibrations.

On this last measurement period, it seemed that the step maintained itself sufficiently stable as shown by the following graphs (perhaps some doubts on gauge 2), where it is also represented a later measurement done by CEM 10 months after the conclusion of the comparison.

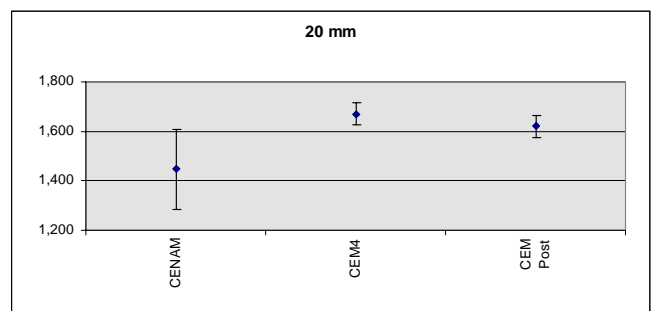

Gauge 1

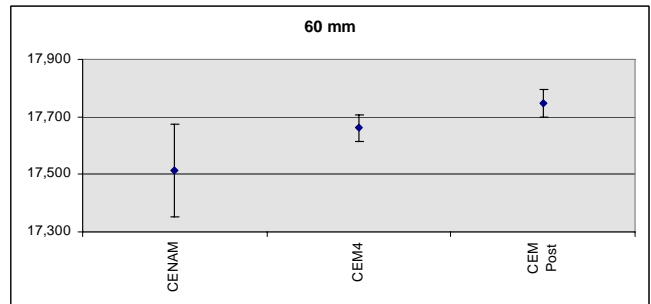
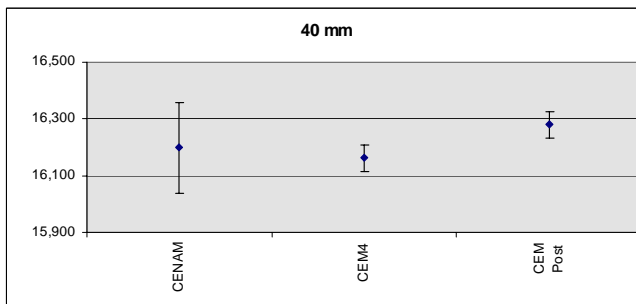

Gauge 2

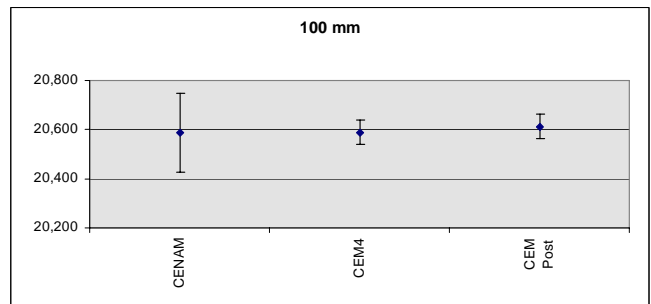
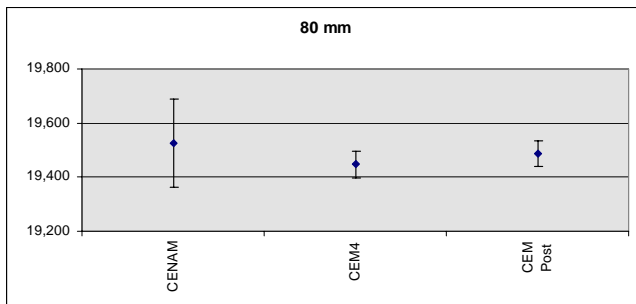

Gauge 3

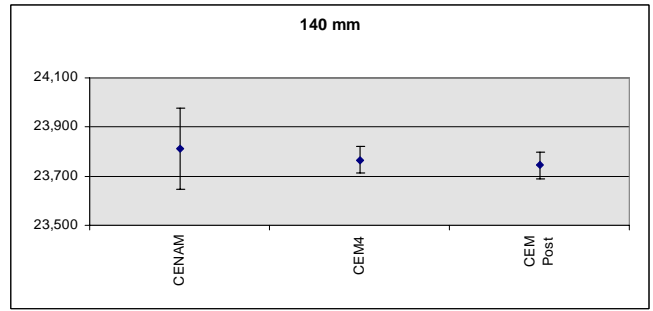
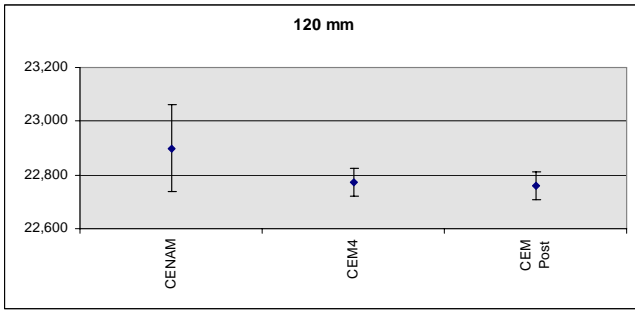

Gauge 4

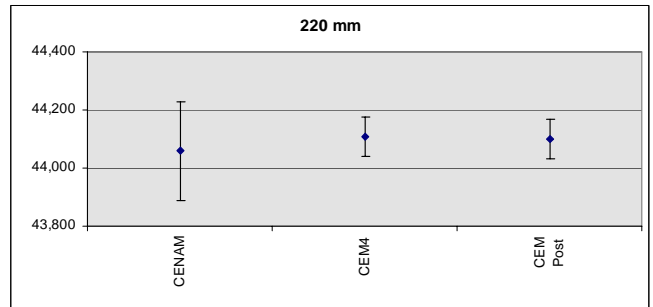
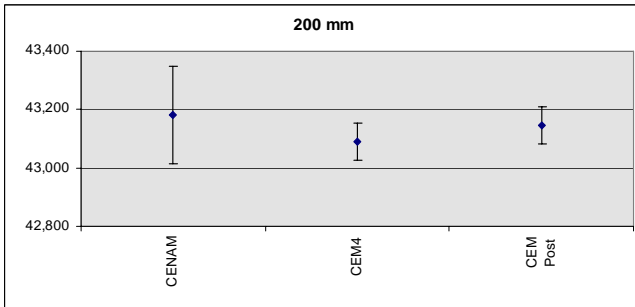

Gauge 6

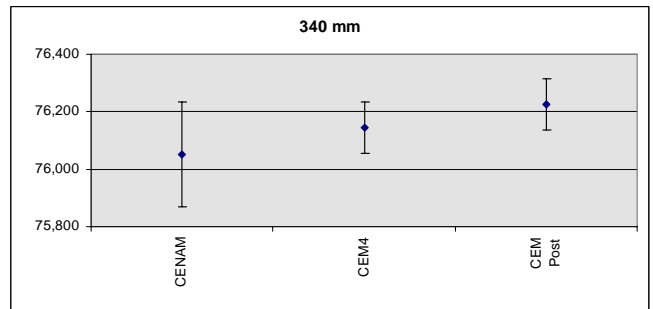
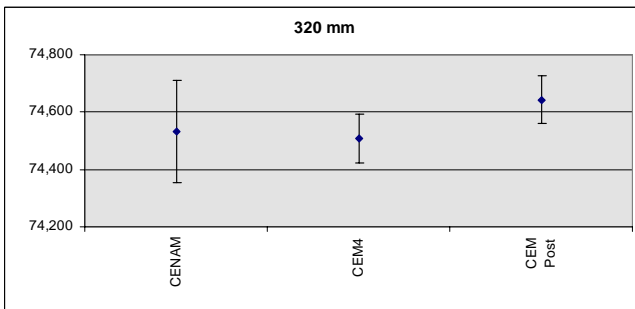

Gauge 9

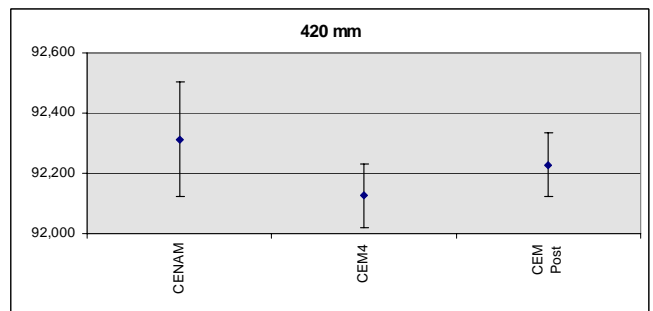
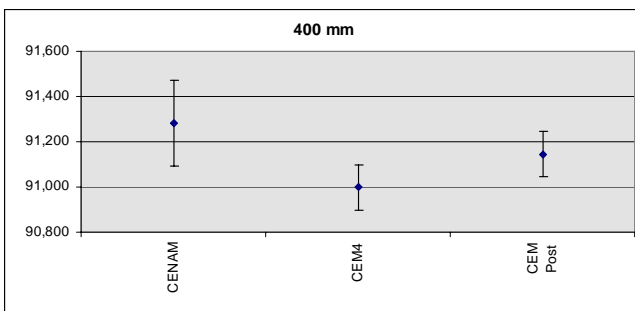

Gauge 11

As for the main group, in order to consider the different uncertainties of the two participants, we have taken as reference value the weighted mean and followed the same calculation procedure.

The results obtained show full compatibility as seen in the following tables and graphs:

10.1 Summary of results CENAM-CEM4

- Deviations to nominal positions and standard uncertainties: $x_i \pm u(x_i)$ (μm)

Date	Lab.	Gauge 1	Gauge 2		Gauge 3	
		20 mm	40 mm	60 mm	80 mm	100 mm
Sep-07	CENAM	1,447 ± 0,161	16,199 ± 0,161	17,512 ± 0,161	19,525 ± 0,162	20,588 ± 0,162
Dec-07	CEM4	1,695 ± 0,045	16,636 ± 0,046	18,388 ± 0,047	19,557 ± 0,048	21,033 ± 0,050

Date	Lab.	Gauge 4		Gauge 6	
		120 mm	140 mm	200 mm	220 mm
Sep-07	CENAM	22,899 ± 0,163	23,812 ± 0,164	43,181 ± 0,168	44,059 ± 0,17
Dec-07	CEM4	23,247 ± 0,052	24,496 ± 0,055	43,092 ± 0,064	44,108 ± 0,067

Date	Lab.	Gauge 9		Gauge 11	
		320 mm	340 mm	400 mm	420 mm
Sep-07	CENAM	74,533 ± 0,179	76,052 ± 0,182	91,282 ± 0,189	92,313 ± 0,192
Dec-07	CEM4	74,508 ± 0,085	76,144 ± 0,089	90,998 ± 0,101	92,125 ± 0,105

- Weighted mean (x_w) and its uncertainty $u(x_w)$ (μm)

	Gauge 1	Gauge 2		Gauge 3		Gauge 4	
	20 mm	40 mm	60 mm	80 mm	100 mm	120 mm	140 mm
x_w	1,654	16,164	17,650	19,453	20,589	22,786	23,771
$u(x_w)$	0,044	0,044	0,045	0,046	0,048	0,050	0,052

	Gauge 6		Gauge 9		Gauge 11	
	200 mm	220 mm	320 mm	340 mm	400 mm	420 mm
x_w	43,103	44,102	74,513	76,126	91,060	92,168
$u(x_w)$	0,060	0,062	0,077	0,080	0,089	0,092

- E_N values

Date	Lab.	Gauge 1	Gauge 2		Gauge 3		Gauge 4	
		20 mm	40 mm	60 mm	80 mm	100 mm	120 mm	140 mm
Sep-07	CENAM	-0,67	0,11	-0,45	0,23	0,00	0,37	0,13
Dec-07	CEM4	0,67	-0,11	0,45	-0,23	0,00	-0,37	-0,13

Date	Lab.	Gauge 6		Gauge 9		Gauge 11	
		200 mm	220 mm	320 mm	340 mm	400 mm	420 mm
Sep-07	CENAM	0,25	-0,13	0,06	-0,23	0,67	0,43
Dec-07	CEM4	-0,25	0,13	-0,06	0,23	-0,67	-0,43

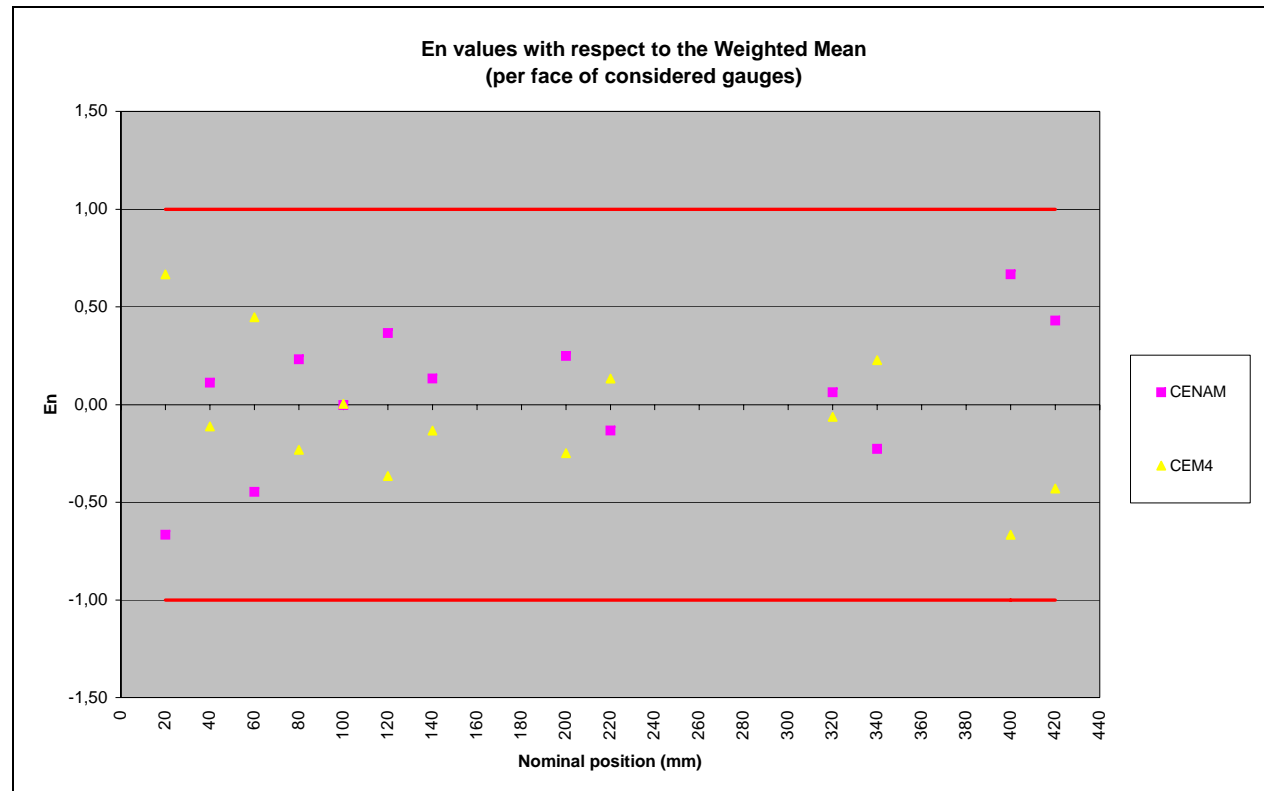

- Birge Ratio

Consistency if BR < 1,956 (L=2)

Date	Lab.	Gauge 1	Gauge 2		Gauge 3		Gauge 4	
		20 mm	40 mm	60 mm	80 mm	100 mm	120 mm	140 mm
Sep-07	CENAM	1,284	0,215	0,856	0,444	0,006	0,698	0,252
Dec-07	CEM4	0,361	0,061	0,250	0,133	0,002	0,225	0,085

Date	Lab.	Gauge 6		Gauge 9		Gauge 11	
		200 mm	220 mm	320 mm	340 mm	400 mm	420 mm
Sep-07	CENAM	0,465	0,250	0,113	0,407	1,174	0,755
Dec-07	CEM4	0,176	0,098	0,054	0,198	0,625	0,411

- Degrees of Equivalence: Deviations to weighted mean and expanded uncertainties of such deviations: $(x_i - x_w) \pm U(x_i - x_w)$ (µm)

Date	Lab.	Gauge 1	Gauge 2		Gauge 3	
		20 mm	40 mm	60 mm	80 mm	100 mm
Sep-07	CENAM	-0,207 ± 0,310	0,035 ± 0,310	-0,138 ± 0,309	0,072 ± 0,310	-0,001 ± 0,309
Dec-07	CEM4	0,016 ± 0,024	-0,003 ± 0,025	0,012 ± 0,026	-0,006 ± 0,028	0,000 ± 0,030

Date	Lab.	Gauge 4		Gauge 6	
		120 mm	140 mm	200 mm	220 mm
Sep-07	CENAM	0,114 ± 0,310	0,041 ± 0,311	0,078 ± 0,314	-0,042 ± 0,316
Dec-07	CEM4	-0,012 ± 0,032	-0,005 ± 0,035	-0,011 ± 0,045	0,007 ± 0,049

Date	Lab.	Gauge 9		Gauge 11	
		320 mm	340 mm	400 mm	420 mm
Sep-07	CENAM	0,020 ± 0,323	-0,074 ± 0,327	0,222 ± 0,334	0,145 ± 0,337
Dec-07	CEM4	-0,005 ± 0,073	0,018 ± 0,078	-0,063 ± 0,095	-0,043 ± 0,100

- Deviations to the weighted mean:

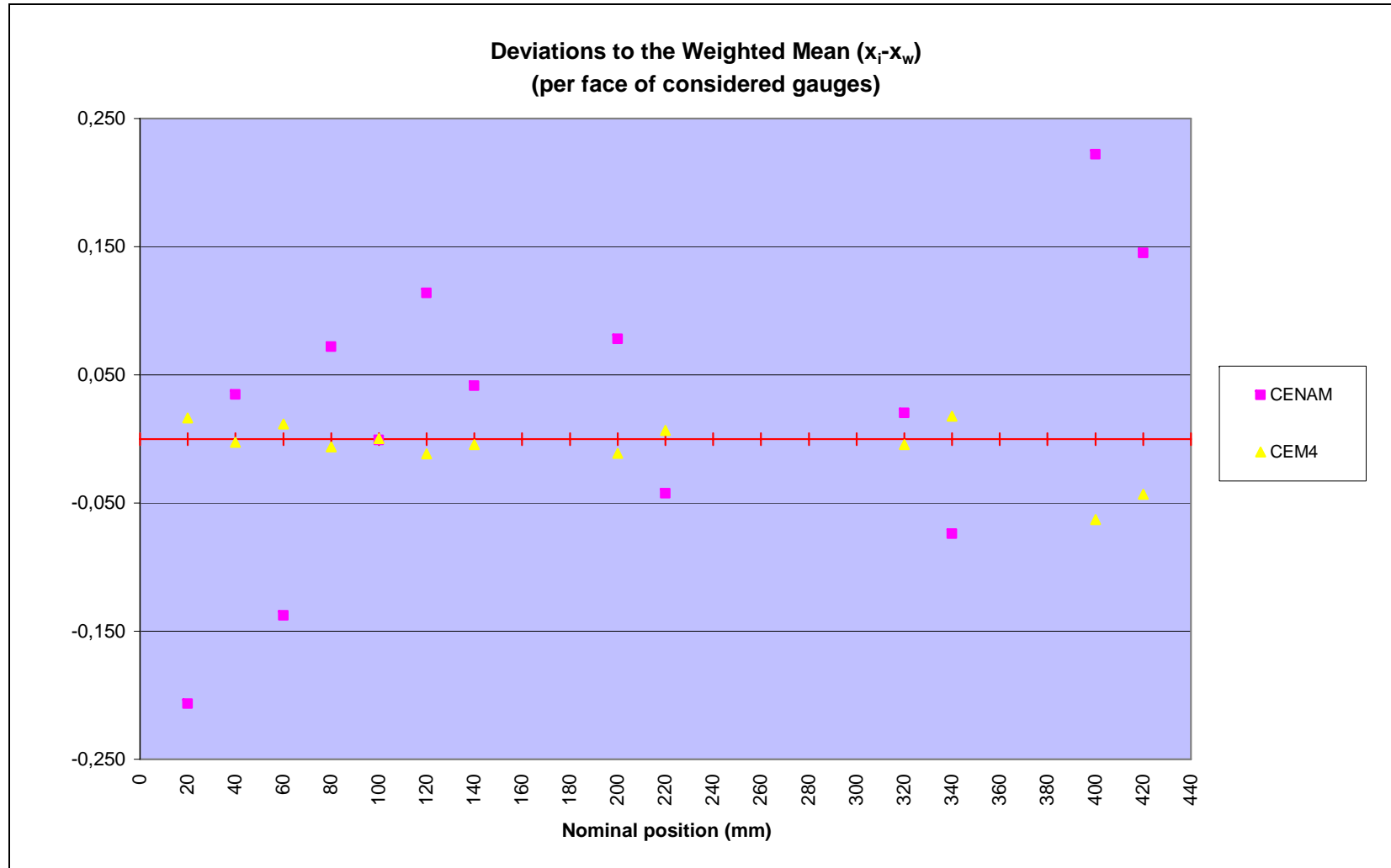

- Graphs showing the unilateral Degrees of Equivalence: $(x_i - x_w) \pm U(x_i - x_w)$ (μm)

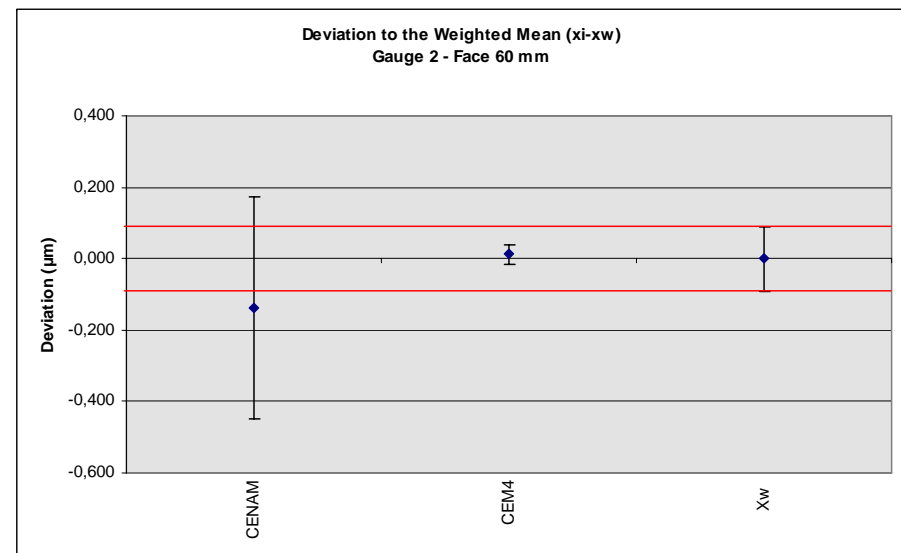
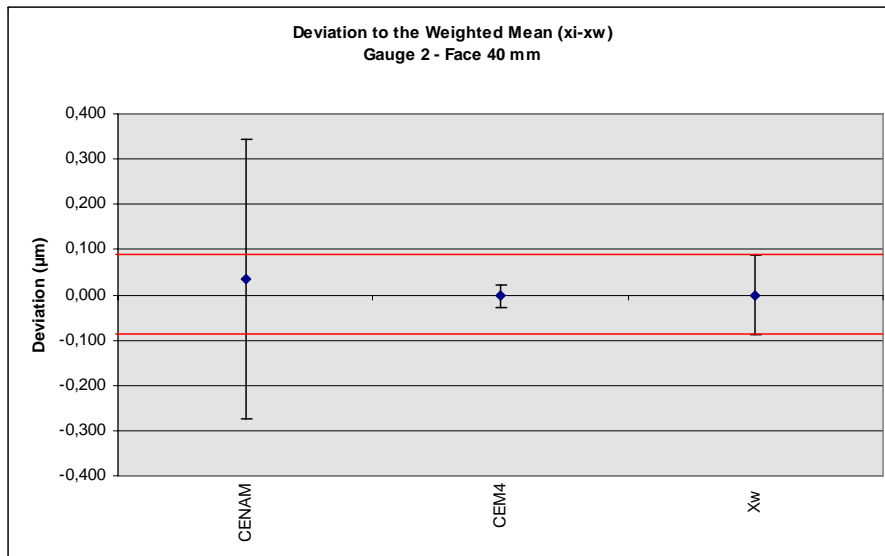
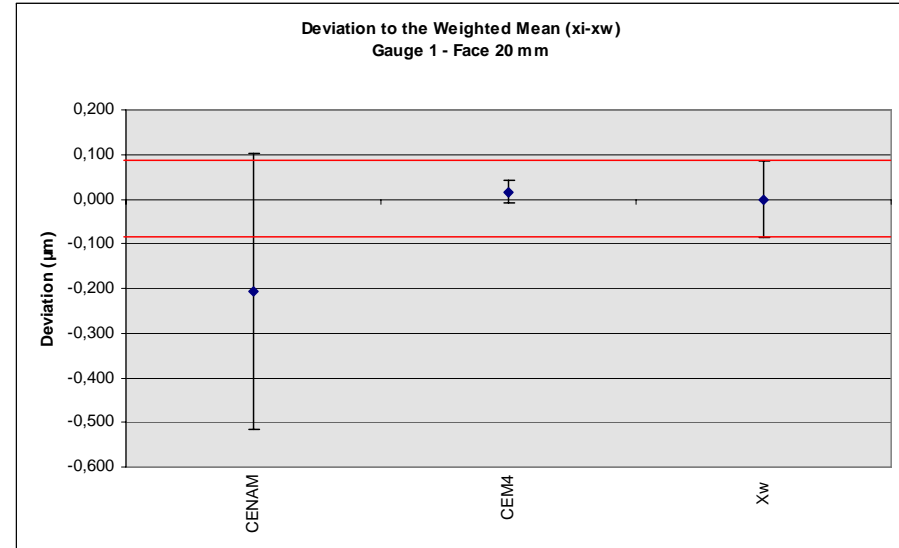

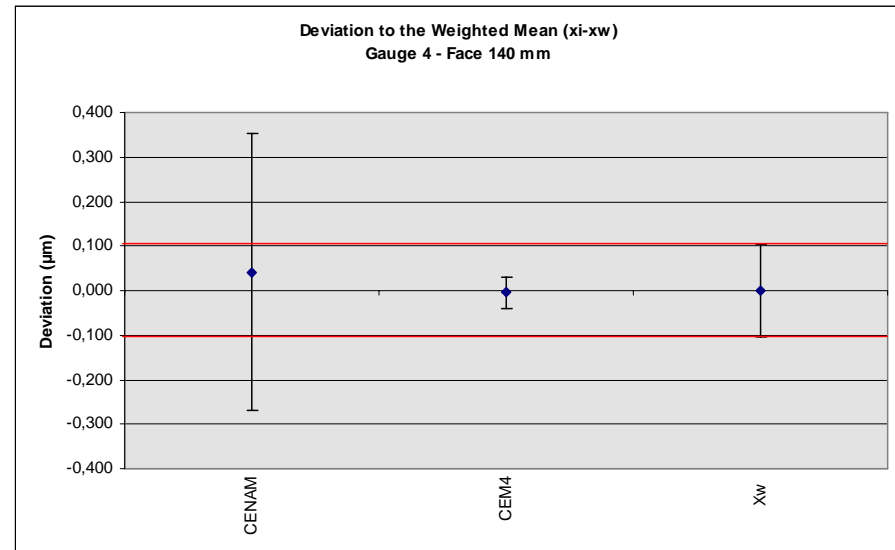
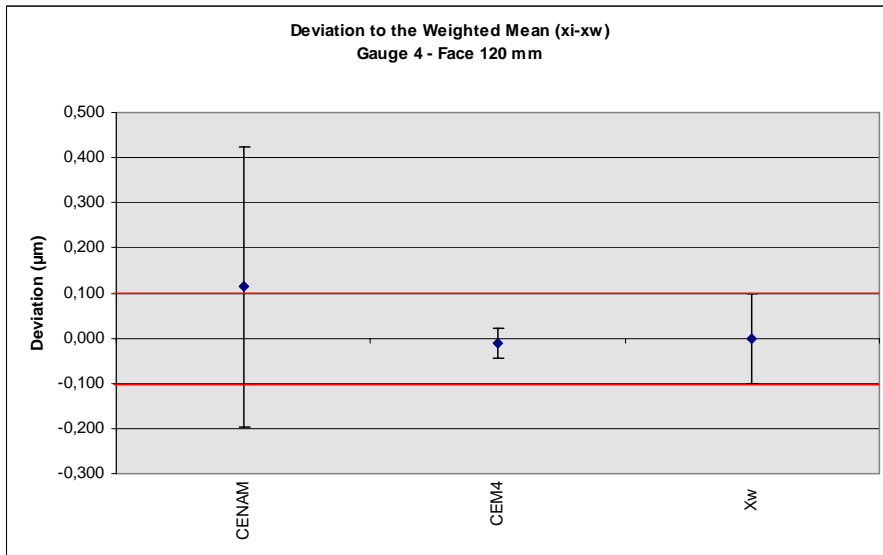
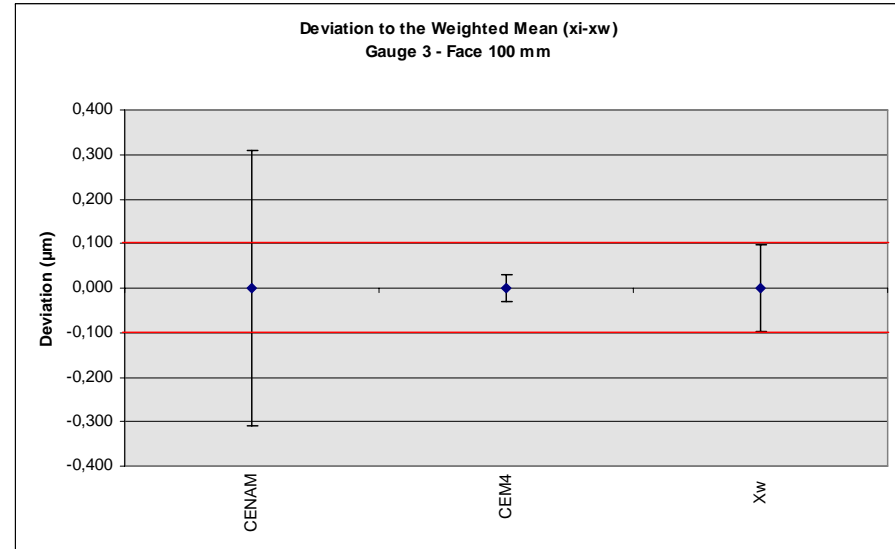
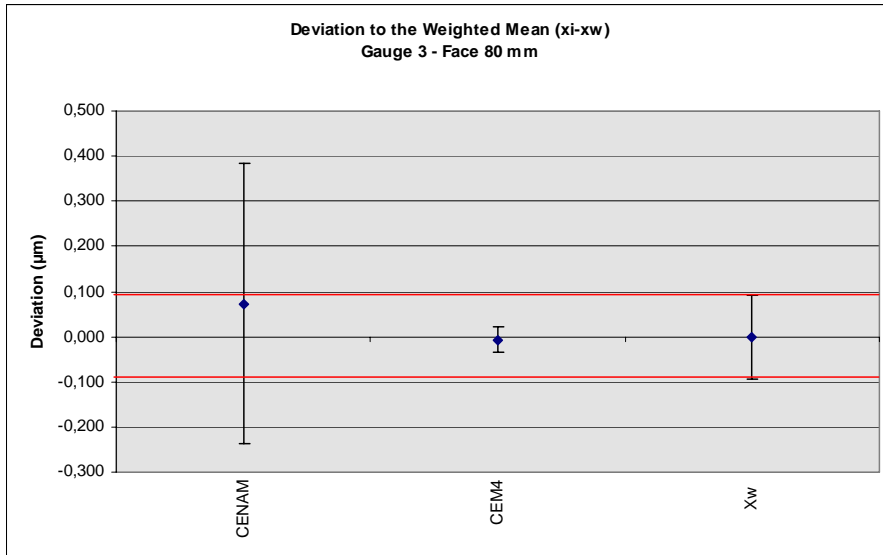

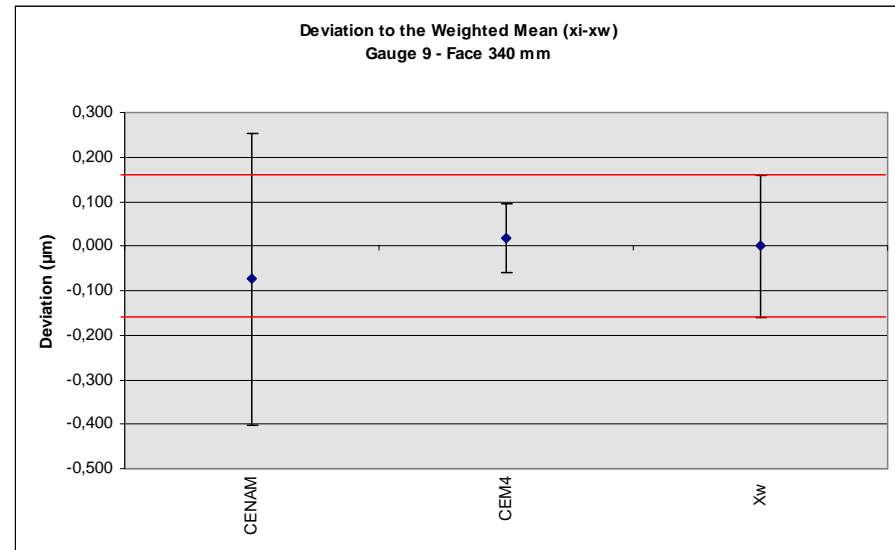
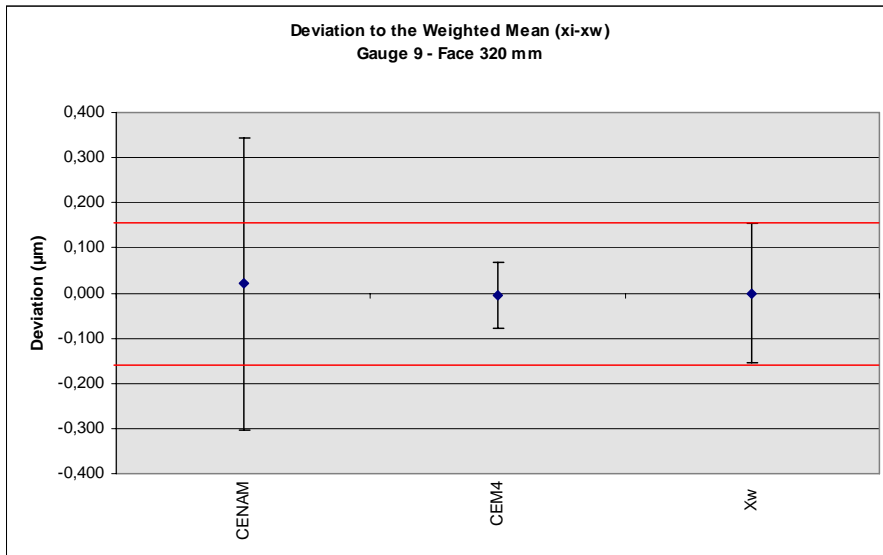
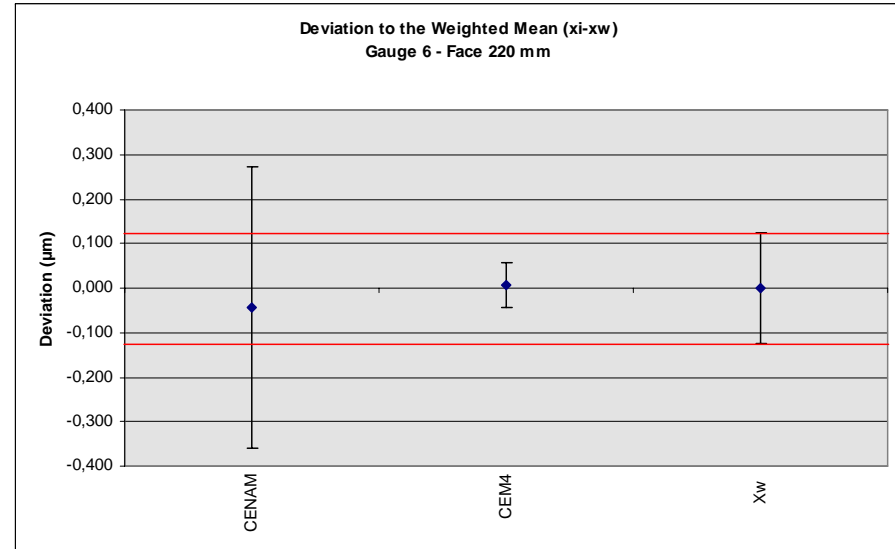
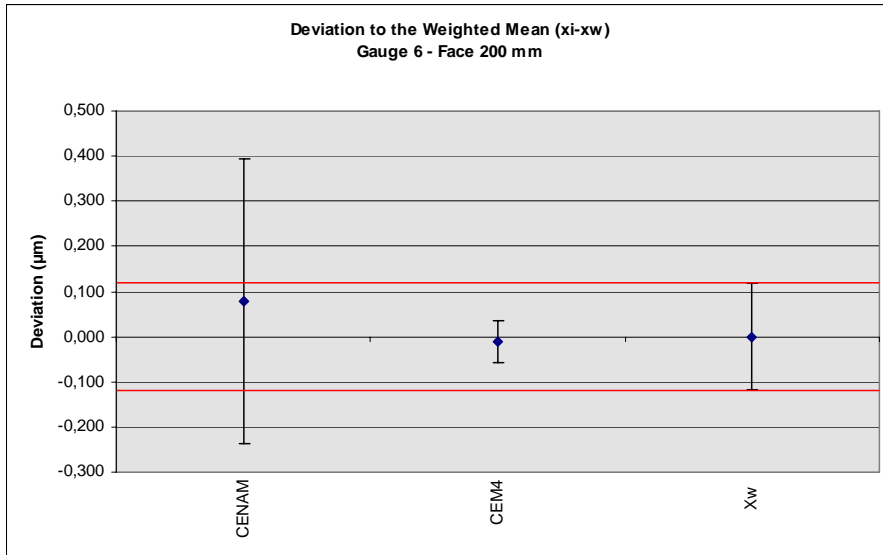

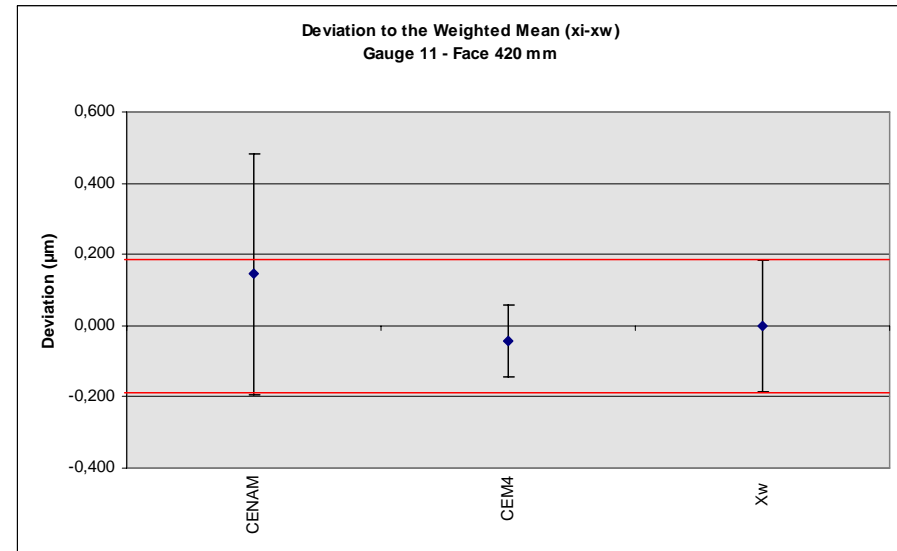
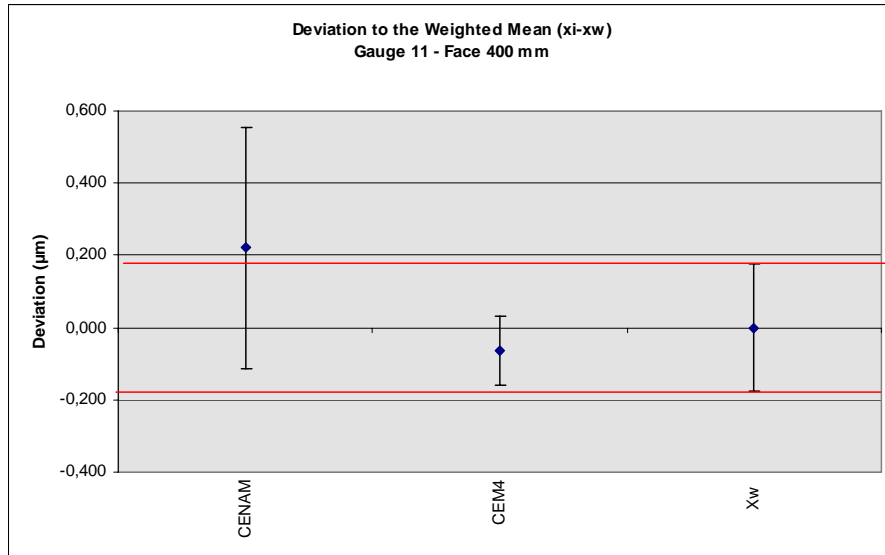

- Degrees of Equivalence between labs, 95 % confidence, demonstrated by the comparison.: $D_{ij} = x_i - x_j$ / $U_{ij} = 2\sqrt{[u(x_i)]^2 + [u(x_j)]^2}$

	Gauge 1		Gauge 2		Gauge 3		Gauge 4		Gauge 6		Gauge 9		Gauge 11	
	20 mm	40 mm	60 mm	80 mm	100 mm	120 mm	140 mm	200 mm	220 mm	320 mm	340 mm	400 mm	420 mm	
D_{ij}	0.248	0.437	0.875	0.032	0.444	0.348	0.684	0.089	0.049	0.025	0.092	0.285	0.188	
U_{ij}	0.334	0.335	0.335	0.338	0.339	0.342	0.346	0.359	0.365	0.396	0.405	0.428	0.437	

11 Linking the two-Lab Group to the main one

In the document CIPM_MRA-D-05 “Measurement comparisons in the CIPM MRA”, it is said:

The results of subsequent key comparisons may be added to the data for the previous key comparison in the KCDB, with a note specifying that these results correspond to the subsequent comparison. Except for BIPM ongoing comparisons, when a Consultative Committee chooses to include new participants, no key comparison reference value is computed for these new results and they are not normally used to modify the key comparison reference value obtained from the results of the original participants.

The results are linked to the original key comparison through the joint participation and the linking laboratories original results remain valid. In such cases, degrees of equivalence are computed for the participants in the subsequent comparison with respect to all other participants and to the previous key comparison reference value.

We are also following this way although the reason motivating the linking to the main group was the instability of the travelling standard.

The idea here behind is to consider that measurement capabilities of both laboratories (represented by their uncertainties and their distances to the 2-Lab weighted mean) have nothing to do with the stability of the step, the different deviations obtained by CENAM and CEM4 being only a consequence of the new actual positions of gauges (new nominal positions for them). So, if the gauges had maintained their positions, their deviations would have been in line with the rest of participants. The shift in gauges position caused the shift in deviations.

This is similar to when calibrating gauge blocks of theoretically the same nominal values, where a small variation in the nominal values used in linked comparisons has no effect on the reference value.

This reasoning permits us to match both weighted means and represent CENAM and CEM4 deviations (obtained with respect to their own weighted mean) on the same common reference, the weighted mean of the main group, in line with doc. CIPM_MRA-D-05, so getting the unilateral DoEs on a common basis, and also the bilateral degrees of equivalence (DoEs).

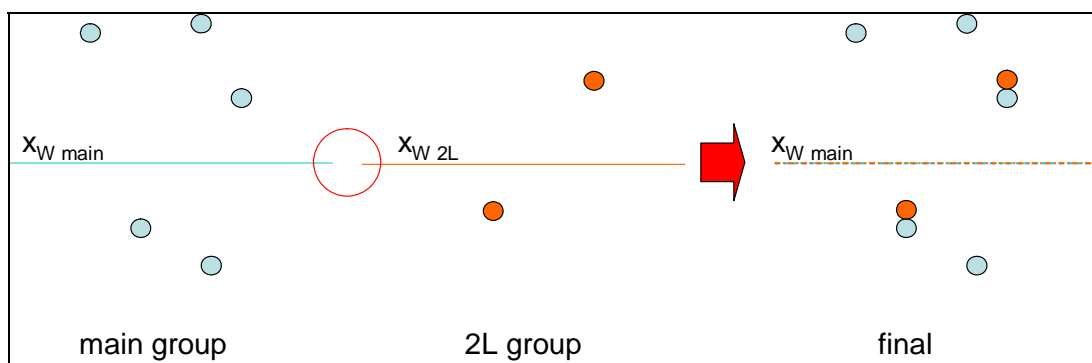

12 Final Summary of Results

- Unilateral DoEs: $(x_i - KCRV) \pm U(x_i - KCRV)$ (μm)

Date	Lab.	Gauge 1	Gauge 2		Gauge 3		Gauge 4	
		20 mm	40 mm	60 mm	80 mm	100 mm	120 mm	140 mm
Feb-05	BEV	-0,209 ± 1,120	0,002 ± 1,014	-0,116 ± 1,145	0,139 ± 1,030	-0,287 ± 1,153	0,236 ± 1,066	-0,292 ± 1,196
Mar-05	NML	0,095 ± 2,200	0,049 ± 2,205	0,368 ± 2,208	-0,104 ± 2,206	0,290 ± 2,205	-0,232 ± 2,214	0,061 ± 2,217
May-05	OMH	0,300 ± 0,881	0,014 ± 0,899	0,081 ± 0,917	0,139 ± 0,923	1,158 ± 0,939	0,620 ± 0,975	0,665 ± 1,001
June-05	SP	-0,078 ± 0,138	-0,071 ± 0,205	-0,077 ± 0,246	-0,101 ± 0,227	-0,122 ± 0,222	-0,161 ± 0,301	-0,182 ± 0,320
July-05	CEM2	0,015 ± 0,085	-0,150 ± 0,170	-0,107 ± 0,215	-0,046 ± 0,191	-0,015 ± 0,183	0,009 ± 0,271	0,051 ± 0,292
Sep-05	CGM	-0,032 ± 0,399	-0,093 ± 0,426	-0,112 ± 0,447	-0,140 ± 0,437	-0,052 ± 0,435	-0,114 ± 0,481	-0,091 ± 0,495
Oct-05	CMI	-0,093 ± 0,299	-0,043 ± 0,334	-0,127 ± 0,361	-0,052 ± 0,350	-0,135 ± 0,349	-0,074 ± 0,406	-0,178 ± 0,424
Nov-05	LNE	-0,220 ± 0,332	0,154 ± 0,366	-0,029 ± 0,394	0,179 ± 0,388	-0,052 ± 0,393	0,210 ± 0,450	0,085 ± 0,473
Dec-05	INM	-0,810 ± 0,940	0,394 ± 0,954	-0,269 ± 0,967	0,639 ± 0,968	-0,272 ± 0,973	0,750 ± 1,002	-0,035 ± 1,017
Feb-06	INRIM	0,125 ± 0,198	0,049 ± 0,248	0,111 ± 0,281	-0,037 ± 0,265	0,005 ± 0,261	-0,089 ± 0,331	-0,046 ± 0,350
Mar-06	NPL	0,080 ± 0,095	0,104 ± 0,175	0,131 ± 0,219	0,079 ± 0,195	0,098 ± 0,187	0,010 ± 0,274	0,045 ± 0,294
June-06	NRC	-0,100 ± 0,218	0,005 ± 0,263	-0,070 ± 0,294	-0,069 ± 0,277	-0,092 ± 0,272	-0,047 ± 0,338	-0,122 ± 0,355
Aug-06	NMIA	0,060 ± 0,380	-0,056 ± 0,410	0,141 ± 0,435	-0,121 ± 0,430	0,168 ± 0,435	-0,030 ± 0,487	0,105 ± 0,509
Sep-06	VNIIM	-0,300 ± 1,540	-12,474 ± 1,549	-10,708 ± 1,558	-2,358 ± 1,560	-1,141 ± 1,565	12,306 ± 1,585	13,149 ± 1,597
Nov-06	MIKES	-0,044 ± 0,151	0,136 ± 0,211	0,093 ± 0,248	0,091 ± 0,226	0,039 ± 0,218	0,115 ± 0,295	0,071 ± 0,313
Dec-06	VSL	-0,004 ± 0,148	0,116 ± 0,212	0,033 ± 0,254	-0,006 ± 0,240	-0,044 ± 0,241	-0,014 ± 0,321	-0,039 ± 0,347
Feb-07	GUM	-0,100 ± 0,820	-0,186 ± 0,833	0,081 ± 0,845	-0,361 ± 0,841	0,558 ± 0,841	-0,380 ± 0,867	0,265 ± 0,876
Apr-07	INMETRO	0,120 ± 0,300	0,004 ± 0,334	0,031 ± 0,360	0,009 ± 0,349	-0,002 ± 0,347	0,010 ± 0,403	-0,085 ± 0,420
Sep-07	CENAM	-0,207 ± 0,310	0,035 ± 0,310	-0,138 ± 0,309	0,072 ± 0,310	-0,001 ± 0,309	0,114 ± 0,310	0,041 ± 0,311
Dec-07	CEM4	0,016 ± 0,024	-0,003 ± 0,025	0,012 ± 0,026	-0,006 ± 0,028	0,000 ± 0,030	-0,012 ± 0,032	-0,005 ± 0,035

Date	Lab.	Gauge 6		Gauge 9		Gauge 11	
		200 mm	220 mm	320 mm	340 mm	400 mm	420 mm
Feb-05	BEV	-0,072 ± 1,099	-0,672 ± 1,234	0,005 ± 1,275	-0,457 ± 1,388	-0,363 ± 1,396	-0,718 ± 1,502
Mar-05	NML	-0,569 ± 2,200	0,088 ± 2,204	-0,340 ± 2,420	0,405 ± 2,415	-0,045 ± 2,424	0,305 ± 2,417
May-05	OMH	0,031 ± 1,043	0,093 ± 1,081	0,202 ± 1,293	0,262 ± 1,324	0,287 ± 1,465	0,090 ± 1,497
June-05	SP	-0,143 ± 0,190	-0,166 ± 0,230	0,107 ± 0,377	0,096 ± 0,349	0,088 ± 0,418	0,056 ± 0,379
July-05	CEM2	-0,070 ± 0,130	-0,014 ± 0,183	0,096 ± 0,351	0,157 ± 0,321	0,082 ± 0,397	0,143 ± 0,356
Sep-05	CGM	-0,182 ± 0,432	-0,158 ± 0,455	-0,081 ± 0,566	-0,046 ± 0,553	0,095 ± 0,616	-0,041 ± 0,597
Oct-05	CMI	-0,081 ± 0,353	-0,168 ± 0,383	0,119 ± 0,521	0,051 ± 0,509	0,148 ± 0,585	0,149 ± 0,568
Nov-05	LNE	0,211 ± 0,440	0,133 ± 0,476	0,312 ± 0,646	0,112 ± 0,649	0,357 ± 0,748	0,360 ± 0,748
Dec-05	INM	0,611 ± 1,022	-0,027 ± 1,045	0,202 ± 1,178	-0,478 ± 1,191	0,757 ± 1,281	-0,120 ± 1,293
Feb-06	INRIM	-0,001 ± 0,246	0,032 ± 0,282	-0,179 ± 0,430	-0,116 ± 0,410	-0,260 ± 0,485	-0,119 ± 0,458
Mar-06	NPL	0,101 ± 0,133	0,093 ± 0,184	-0,068 ± 0,349	-0,028 ± 0,318	-0,013 ± 0,393	0,030 ± 0,351
June-06	NRC	0,021 ± 0,242	-0,022 ± 0,274	-0,126 ± 0,408	-0,185 ± 0,383	-0,059 ± 0,450	-0,162 ± 0,415
Aug-06	NMIA	0,131 ± 0,480	0,243 ± 0,513	0,132 ± 0,676	0,212 ± 0,680	0,067 ± 0,776	0,210 ± 0,777
Sep-06	VNIIM	7,220 ± 1,610	7,481 ± 1,629	-0,298 ± 1,740	1,262 ± 1,754	3,180 ± 1,834	1,786 ± 1,850
Nov-06	MIKES	0,049 ± 0,164	0,054 ± 0,206	-0,136 ± 0,353	-0,170 ± 0,320	-0,065 ± 0,388	-0,094 ± 0,344
Dec-06	VSL	-0,096 ± 0,271	-0,143 ± 0,315	-0,298 ± 0,495	-0,321 ± 0,489	-0,236 ± 0,583	-0,246 ± 0,572
Feb-07	GUM	0,731 ± 0,847	0,693 ± 0,862	0,902 ± 0,939	0,762 ± 0,935	-0,613 ± 0,984	-0,010 ± 0,977
Apr-07	INMETRO	0,541 ± 0,352	0,483 ± 0,381	0,422 ± 0,501	0,372 ± 0,486	-0,133 ± 0,557	-0,100 ± 0,536
Sep-07	CENAM	0,078 ± 0,314	-0,042 ± 0,316	0,020 ± 0,323	-0,074 ± 0,327	0,222 ± 0,334	0,145 ± 0,337
Dec-07	CEM4	-0,011 ± 0,045	0,007 ± 0,049	-0,005 ± 0,073	0,018 ± 0,078	-0,063 ± 0,095	-0,043 ± 0,100

- Graphs showing unilateral DoEs:

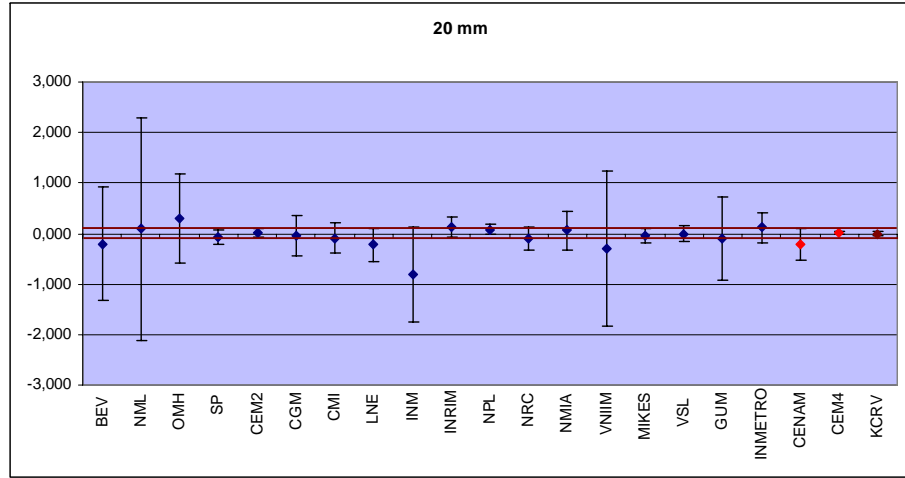

Gauge 1

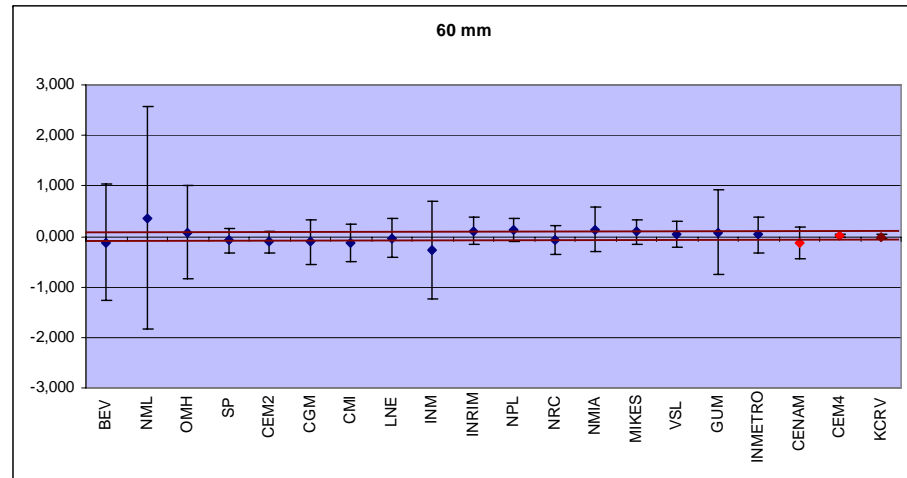
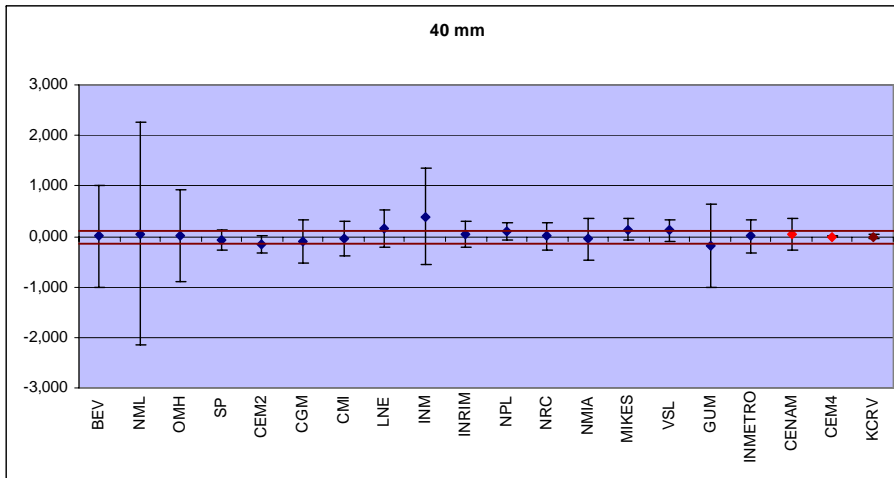

Gauge 2

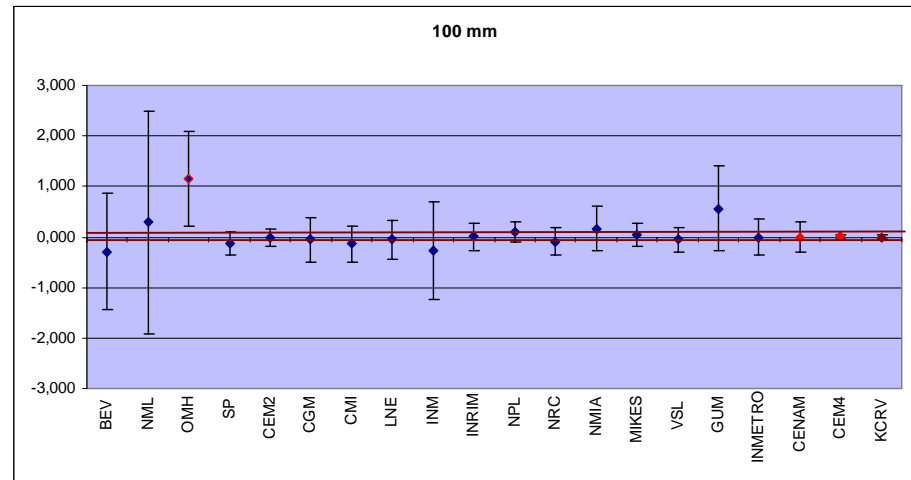
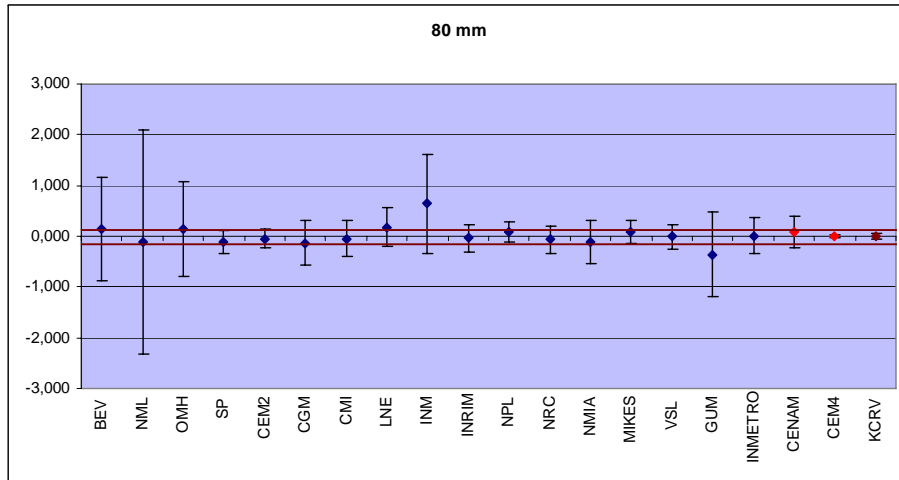

Gauge 3

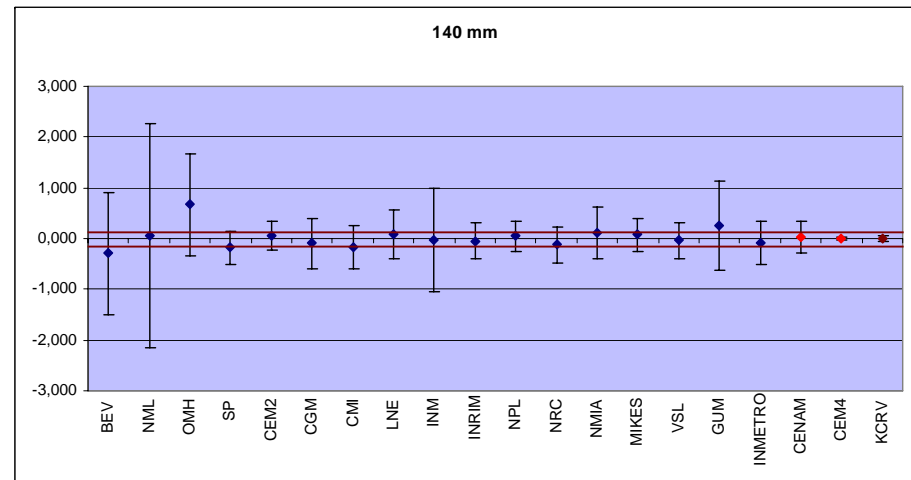
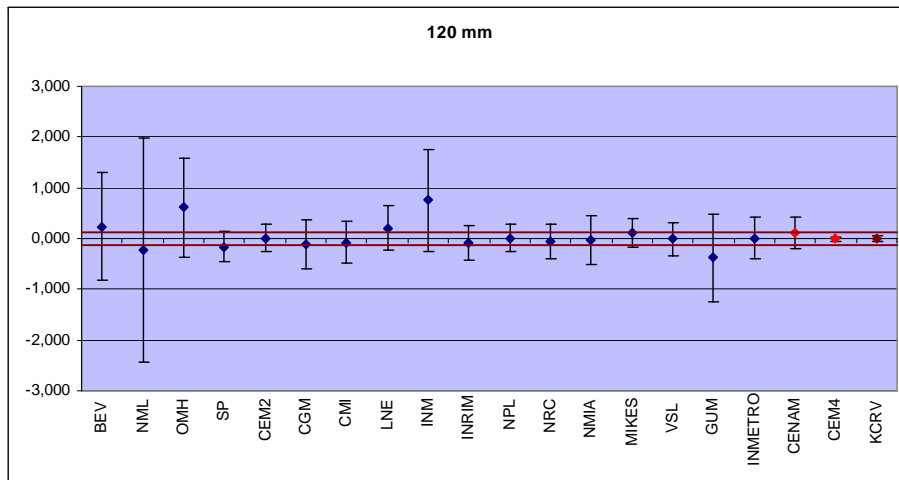

Gauge 4

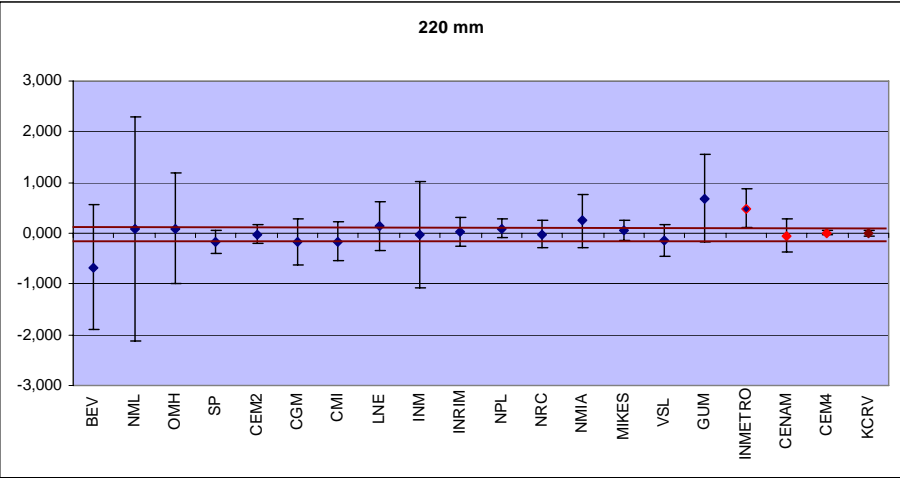
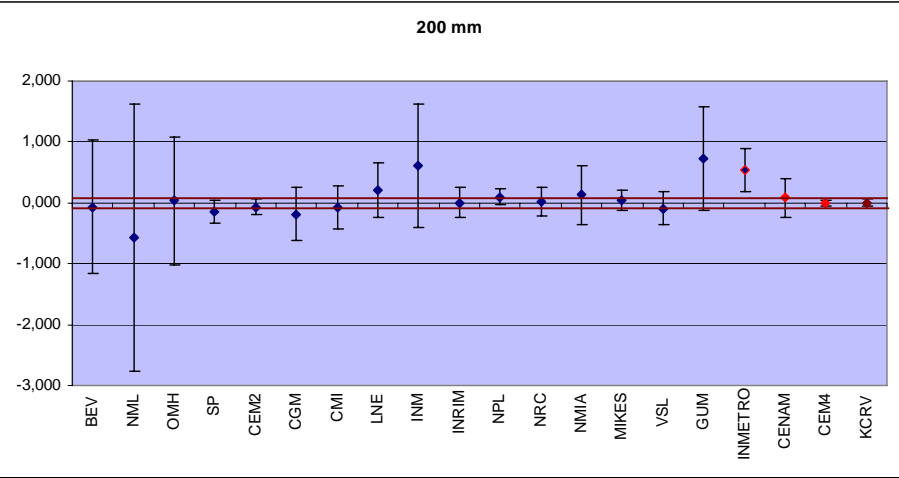

Gauge 6

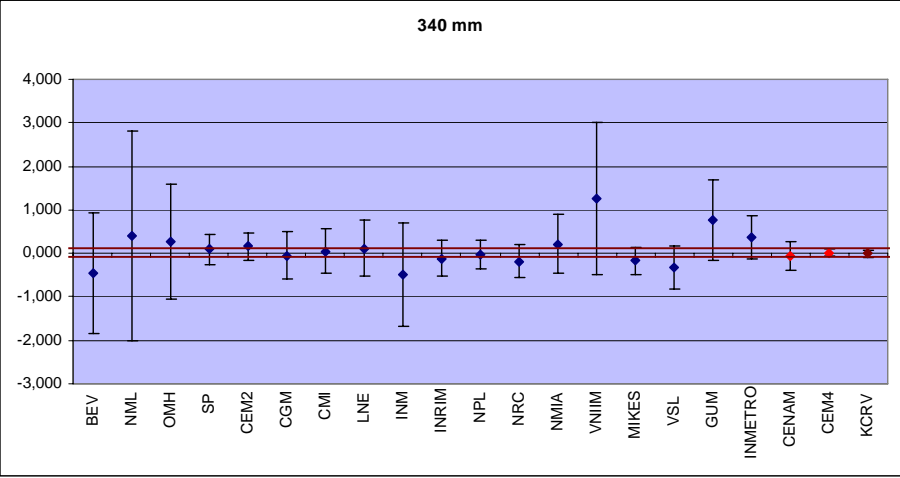
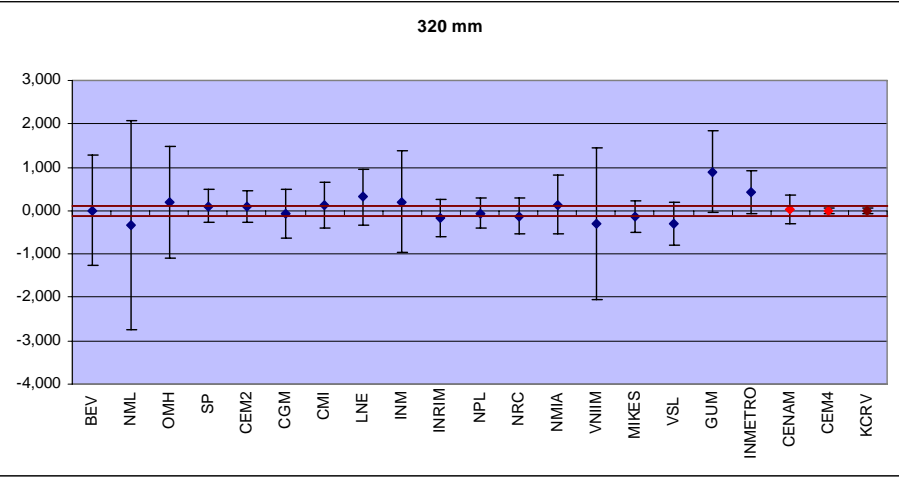

Gauge 9

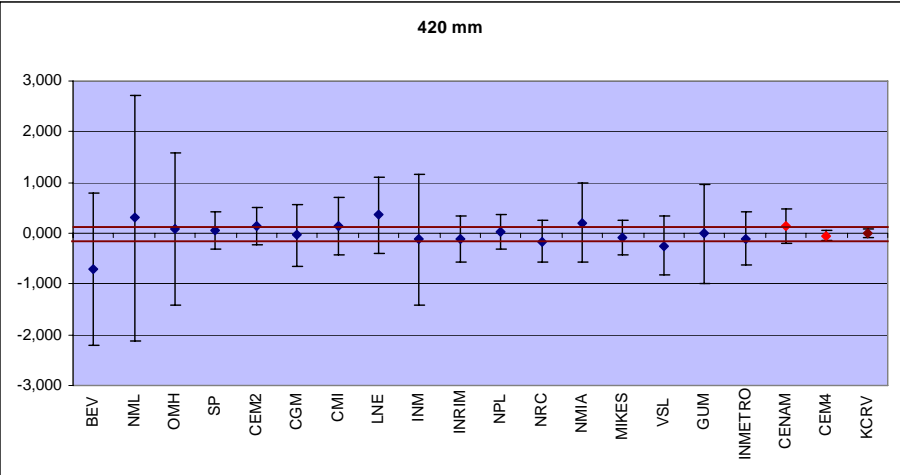
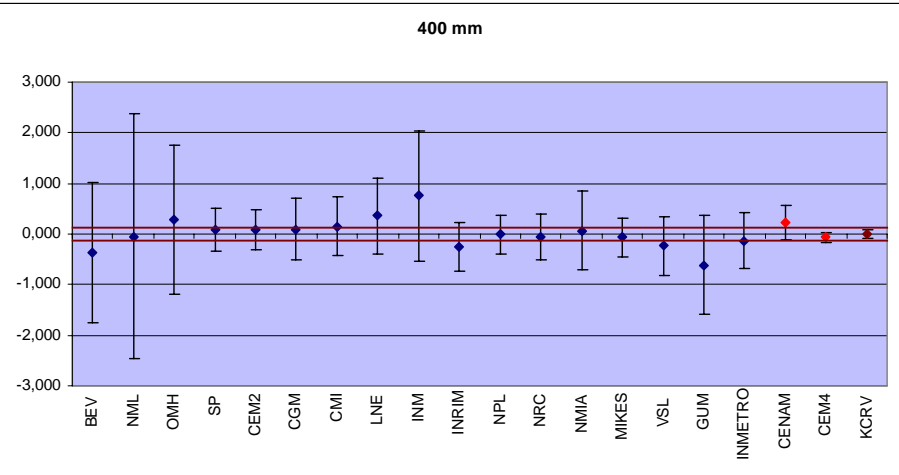

Gauge 11

- Bilateral Degrees of Equivalence between labs: $D_{ij} = x_i - x_j$ / $U_{ij} = 2\sqrt{[u(x_i)]^2 + [u(x_j)]^2}$

Gauge 1 20 mm	BEV		NML		OMH		SP		CEM2		CGM		CMI	
	$D_{ij} / \mu\text{m}$	$U_{ij} / \mu\text{m}$	$D_{ij} / \mu\text{m}$	$U_{ij} / \mu\text{m}$	$D_{ij} / \mu\text{m}$	$U_{ij} / \mu\text{m}$	$D_{ij} / \mu\text{m}$	$U_{ij} / \mu\text{m}$	$D_{ij} / \mu\text{m}$	$U_{ij} / \mu\text{m}$	$D_{ij} / \mu\text{m}$	$U_{ij} / \mu\text{m}$	$D_{ij} / \mu\text{m}$	$U_{ij} / \mu\text{m}$
BEV			-0,304	2,420	-0,509	1,398	-0,131	1,107	-0,224	1,102	-0,177	1,166	-0,115	1,137
NML	0,304	2,420			-0,205	2,323	0,173	2,160	0,080	2,158	0,127	2,191	0,188	2,176
OMH	0,509	1,398	0,205	2,323			0,378	0,875	0,285	0,869	0,332	0,949	0,393	0,913
SP	0,131	1,107	-0,173	2,160	-0,378	0,875			-0,093	0,164	-0,046	0,416	0,016	0,325
CEM2	0,224	1,102	-0,080	2,158	-0,285	0,869	0,093	0,164			0,047	0,402	0,108	0,308
CGM	0,177	1,166	-0,127	2,191	-0,332	0,949	0,046	0,416	-0,047	0,402			0,061	0,491
CMI	0,115	1,137	-0,188	2,176	-0,393	0,913	-0,016	0,325	-0,108	0,308	-0,061	0,491		
LNE	-0,011	1,146	-0,315	2,181	-0,520	0,924	-0,142	0,355	-0,235	0,338	-0,188	0,510	-0,127	0,440
INM	-0,601	1,434	-0,905	2,345	-1,110	1,264	-0,732	0,932	-0,825	0,926	-0,778	1,002	-0,717	0,968
INRIM	0,334	1,116	0,030	2,165	-0,175	0,886	0,203	0,240	0,110	0,216	0,157	0,439	0,219	0,354
NPL	0,289	1,103	-0,015	2,158	-0,220	0,870	0,158	0,170	0,065	0,132	0,112	0,404	0,173	0,311
NRC	0,108	1,120	-0,195	2,167	-0,400	0,891	-0,023	0,256	-0,115	0,233	-0,068	0,448	-0,007	0,365
NMIA	0,269	1,160	-0,035	2,188	-0,240	0,941	0,138	0,398	0,045	0,384	0,092	0,542	0,153	0,476
VNIIM	-0,091	1,867	-0,395	2,632	-0,600	1,740	-0,222	1,516	-0,315	1,513	-0,268	1,560	-0,207	1,538
MIKES	0,164	1,109	-0,139	2,161	-0,344	0,877	0,033	0,205	-0,059	0,175	-0,012	0,420	0,049	0,331
VSL	0,204	1,109	-0,099	2,161	-0,304	0,877	0,073	0,203	-0,019	0,173	0,028	0,420	0,089	0,330
GUM	0,109	1,361	-0,195	2,301	-0,400	1,180	-0,022	0,816	-0,115	0,809	-0,068	0,895	-0,007	0,856
INMETRO	0,329	1,138	0,025	2,176	-0,180	0,913	0,198	0,327	0,105	0,309	0,152	0,491	0,213	0,418
CENAM	0,056	1,143	-0,248	2,179	-0,453	0,920	-0,075	0,345	-0,168	0,328	-0,121	0,503	-0,060	0,432
CEM4	0,304	1,102	0,000	2,158	-0,205	0,869	0,173	0,164	0,080	0,125	0,127	0,402	0,188	0,308

Gauge 1 20 mm	LNE		INM		INRIM		NPL		NRC		NMIA		VNIIM	
	$D_{ij} / \mu\text{m}$	$U_{ij} / \mu\text{m}$	$D_{ij} / \mu\text{m}$	$U_{ij} / \mu\text{m}$	$D_{ij} / \mu\text{m}$	$U_{ij} / \mu\text{m}$	$D_{ij} / \mu\text{m}$	$U_{ij} / \mu\text{m}$	$D_{ij} / \mu\text{m}$	$U_{ij} / \mu\text{m}$	$D_{ij} / \mu\text{m}$	$U_{ij} / \mu\text{m}$	$D_{ij} / \mu\text{m}$	$U_{ij} / \mu\text{m}$
BEV	0,011	1,146	0,601	1,434	-0,334	1,116	-0,289	1,103	-0,108	1,120	-0,269	1,160	0,091	1,867
NML	0,315	2,181	0,905	2,345	-0,030	2,165	0,015	2,158	0,195	2,167	0,035	2,188	0,395	2,632
OMH	0,520	0,924	1,110	1,264	0,175	0,886	0,220	0,870	0,400	0,891	0,240	0,941	0,600	1,740
SP	0,142	0,355	0,732	0,932	-0,203	0,240	-0,158	0,170	0,023	0,256	-0,138	0,398	0,222	1,516
CEM2	0,235	0,338	0,825	0,926	-0,110	0,216	-0,065	0,132	0,115	0,233	-0,045	0,384	0,315	1,513
CGM	0,188	0,510	0,778	1,002	-0,157	0,439	-0,112	0,404	0,068	0,448	-0,092	0,542	0,268	1,560
CMI	0,127	0,440	0,717	0,968	-0,219	0,354	-0,173	0,311	0,007	0,365	-0,153	0,476	0,207	1,538
LNE			0,590	0,978	-0,345	0,381	-0,300	0,341	-0,120	0,391	-0,280	0,496	0,080	1,545
INM	-0,590	0,978			-0,935	0,943	-0,890	0,927	-0,710	0,947	-0,870	0,995	-0,510	1,769
INRIM	0,345	0,381	0,935	0,943			0,045	0,220	0,226	0,292	0,065	0,422	0,425	1,523
NPL	0,300	0,341	0,890	0,927	-0,045	0,220			0,180	0,237	0,020	0,386	0,380	1,513
NRC	0,120	0,391	0,710	0,947	-0,226	0,292	-0,180	0,237			-0,160	0,431	0,200	1,525
NMIA	0,280	0,496	0,870	0,995	-0,065	0,422	-0,020	0,386	0,160	0,431			0,360	1,555
VNIIM	-0,080	1,545	0,510	1,769	-0,425	1,523	-0,380	1,513	-0,200	1,525	-0,360	1,555		
MIKES	0,176	0,360	0,766	0,934	-0,170	0,248	-0,124	0,180	0,056	0,263	-0,104	0,403	0,256	1,517
VSL	0,216	0,359	0,806	0,934	-0,130	0,246	-0,084	0,178	0,096	0,262	-0,064	0,402	0,296	1,517
GUM	0,120	0,868	0,710	1,223	-0,225	0,828	-0,180	0,810	0,000	0,832	-0,160	0,886	0,200	1,711
INMETRO	0,340	0,441	0,930	0,968	-0,005	0,355	0,040	0,312	0,220	0,366	0,060	0,477	0,420	1,539
CENAM	0,067	0,454	0,657	0,975	-0,279	0,372	-0,233	0,331	-0,053	0,382	-0,213	0,489	0,147	1,543
CEM4	0,315	0,338	0,905	0,926	-0,030	0,216	0,015	0,132	0,195	0,233	0,035	0,384	0,395	1,513

Gauge 1 20 mm	MIKES		VSL		GUM		INMETRO		CENAM		CEM4	
	$D_{ij} / \mu\text{m}$	$U_{ij} / \mu\text{m}$	$D_{ij} / \mu\text{m}$	$U_{ij} / \mu\text{m}$	$D_{ij} / \mu\text{m}$	$U_{ij} / \mu\text{m}$	$D_{ij} / \mu\text{m}$	$U_{ij} / \mu\text{m}$	$D_{ij} / \mu\text{m}$	$U_{ij} / \mu\text{m}$	$D_{ij} / \mu\text{m}$	$U_{ij} / \mu\text{m}$
BEV	-0,164	1,109	-0,204	1,109	-0,109	1,361	-0,329	1,138	-0,056	1,143	-0,304	1,102
NML	0,139	2,161	0,099	2,161	0,195	2,301	-0,025	2,176	0,248	2,179	0,000	2,158
OMH	0,344	0,877	0,304	0,877	0,400	1,180	0,180	0,913	0,453	0,920	0,205	0,869
SP	-0,033	0,205	-0,073	0,203	0,022	0,816	-0,198	0,327	0,075	0,345	-0,173	0,164
CEM2	0,059	0,175	0,019	0,173	0,115	0,809	-0,105	0,309	0,168	0,328	-0,080	0,125
CGM	0,012	0,420	-0,028	0,420	0,068	0,895	-0,152	0,491	0,121	0,503	-0,127	0,402
CMI	-0,049	0,331	-0,089	0,330	0,007	0,856	-0,213	0,418	0,060	0,432	-0,188	0,308
LNE	-0,176	0,360	-0,216	0,359	-0,120	0,868	-0,340	0,441	-0,067	0,454	-0,315	0,338
INM	-0,766	0,934	-0,806	0,934	-0,710	1,223	-0,930	0,968	-0,657	0,975	-0,905	0,926
INRIM	0,170	0,248	0,130	0,246	0,225	0,828	0,005	0,355	0,279	0,372	0,030	0,216
NPL	0,124	0,180	0,084	0,178	0,180	0,810	-0,040	0,312	0,233	0,331	-0,015	0,132
NRC	-0,056	0,263	-0,096	0,262	0,000	0,832	-0,220	0,366	0,053	0,382	-0,195	0,233
NMIA	0,104	0,403	0,064	0,402	0,160	0,886	-0,060	0,477	0,213	0,489	-0,035	0,384
VNIIM	-0,256	1,517	-0,296	1,517	-0,200	1,711	-0,420	1,539	-0,147	1,543	-0,395	1,513
MIKES			-0,040	0,212	0,056	0,818	-0,164	0,332	0,109	0,350	-0,139	0,175
VSL	0,040	0,212			0,096	0,818	-0,124	0,331	0,149	0,349	-0,099	0,173
GUM	-0,056	0,818	-0,096	0,818			-0,220	0,857	0,053	0,864	-0,195	0,809
INMETRO	0,164	0,332	0,124	0,331	0,220	0,857			0,273	0,433	0,025	0,309
CENAM	-0,109	0,350	-0,149	0,349	-0,053	0,864	-0,273	0,433			-0,248	0,328
CEM4	0,139	0,175	0,099	0,173	0,195	0,809	-0,025	0,309	0,248	0,328		

Gauge 2	BEV		NML		OMH		SP		CEM2		CGM		CMI	
40 mm	$D_{ij} / \mu\text{m}$	$U_{ij} / \mu\text{m}$	$D_{ij} / \mu\text{m}$	$U_{ij} / \mu\text{m}$	$D_{ij} / \mu\text{m}$	$U_{ij} / \mu\text{m}$	$D_{ij} / \mu\text{m}$	$U_{ij} / \mu\text{m}$	$D_{ij} / \mu\text{m}$	$U_{ij} / \mu\text{m}$	$D_{ij} / \mu\text{m}$	$U_{ij} / \mu\text{m}$	$D_{ij} / \mu\text{m}$	$U_{ij} / \mu\text{m}$
BEV			-0,047	2,370	-0,011	1,313	0,073	0,994	0,152	0,988	0,095	1,060	0,045	1,028
NML	0,047	2,370			0,036	2,325	0,120	2,161	0,199	2,158	0,143	2,192	0,093	2,176
OMH	0,011	1,313	-0,036	2,325			0,085	0,881	0,163	0,874	0,107	0,954	0,057	0,918
SP	-0,073	0,994	-0,120	2,161	-0,085	0,881			0,079	0,169	0,022	0,419	-0,028	0,329
CEM2	-0,152	0,988	-0,199	2,158	-0,163	0,874	-0,079	0,169			-0,057	0,403	-0,106	0,310
CGM	-0,095	1,060	-0,143	2,192	-0,107	0,954	-0,022	0,419	0,057	0,403			-0,050	0,492
CMI	-0,045	1,028	-0,093	2,176	-0,057	0,918	0,028	0,329	0,106	0,310	0,050	0,492		
LNE	0,151	1,038	0,104	2,181	0,140	0,930	0,225	0,360	0,303	0,342	0,247	0,514	0,197	0,444
INM	0,391	1,350	0,344	2,346	0,380	1,269	0,465	0,936	0,543	0,929	0,487	1,005	0,437	0,971
INRIM	0,046	1,004	-0,001	2,165	0,035	0,892	0,120	0,244	0,198	0,217	0,142	0,440	0,092	0,356
NPL	0,101	0,989	0,054	2,158	0,090	0,875	0,175	0,175	0,253	0,134	0,197	0,406	0,147	0,312
NRC	0,003	1,008	-0,044	2,167	-0,008	0,896	0,076	0,260	0,155	0,234	0,099	0,449	0,049	0,367
NMIA	-0,059	1,054	-0,106	2,189	-0,070	0,948	0,015	0,403	0,093	0,387	0,037	0,545	-0,013	0,479
VNIIM	-12,489	1,803	-12,536	2,633	-12,500	1,743	-12,415	1,518	-12,337	1,514	-12,393	1,562	-12,443	1,540
MIKES	0,134	0,996	0,087	2,161	0,123	0,882	0,207	0,208	0,286	0,176	0,229	0,421	0,179	0,333
VSL	0,114	0,996	0,067	2,161	0,103	0,883	0,187	0,210	0,266	0,178	0,210	0,422	0,160	0,334
GUM	-0,189	1,271	-0,236	2,301	-0,200	1,185	-0,115	0,817	-0,037	0,810	-0,093	0,896	-0,143	0,857
INMETRO	0,001	1,028	-0,046	2,176	-0,010	0,918	0,075	0,329	0,153	0,309	0,097	0,492	0,047	0,419
CENAM	-0,390	1,033	-0,437	2,179	-0,401	0,925	-0,316	0,347	-0,238	0,328	-0,294	0,504	-0,344	0,433
CEM4	0,047	0,988	0,000	2,158	0,036	0,874	0,120	0,169	0,199	0,127	0,143	0,403	0,093	0,310

Gauge 2	LNE		INM		INRIM		NPL		NRC		NMIA		VNIIM	
40 mm	$D_{ij} / \mu\text{m}$	$U_{ij} / \mu\text{m}$	$D_{ij} / \mu\text{m}$	$U_{ij} / \mu\text{m}$	$D_{ij} / \mu\text{m}$	$U_{ij} / \mu\text{m}$	$D_{ij} / \mu\text{m}$	$U_{ij} / \mu\text{m}$	$D_{ij} / \mu\text{m}$	$U_{ij} / \mu\text{m}$	$D_{ij} / \mu\text{m}$	$U_{ij} / \mu\text{m}$	$D_{ij} / \mu\text{m}$	$U_{ij} / \mu\text{m}$
BEV	-0,151	1,038	-0,391	1,350	-0,046	1,004	-0,101	0,989	-0,003	1,008	0,059	1,054	12,489	1,803
NML	-0,104	2,181	-0,344	2,346	0,001	2,165	-0,054	2,158	0,044	2,167	0,106	2,189	12,536	2,633
OMH	-0,140	0,930	-0,380	1,269	-0,035	0,892	-0,090	0,875	0,008	0,896	0,070	0,948	12,500	1,743
SP	-0,225	0,360	-0,465	0,936	-0,120	0,244	-0,175	0,175	-0,076	0,260	-0,015	0,403	12,415	1,518
CEM2	-0,303	0,342	-0,543	0,929	-0,198	0,217	-0,253	0,134	-0,155	0,234	-0,093	0,387	12,337	1,514
CGM	-0,247	0,514	-0,487	1,005	-0,142	0,440	-0,197	0,406	-0,099	0,449	-0,037	0,545	12,393	1,562
CMI	-0,197	0,444	-0,437	0,971	-0,092	0,356	-0,147	0,312	-0,049	0,367	0,013	0,479	12,443	1,540
LNE			-0,240	0,982	0,105	0,385	0,050	0,345	0,148	0,395	0,210	0,501	12,640	1,547
INM	0,240	0,982			0,345	0,945	0,290	0,930	0,388	0,950	0,450	0,998	12,880	1,772
INRIM	-0,105	0,385	-0,345	0,945			-0,055	0,221	0,043	0,293	0,105	0,426	12,535	1,524
NPL	-0,050	0,345	-0,290	0,930	0,055	0,221			0,098	0,238	0,160	0,390	12,590	1,514
NRC	-0,148	0,395	-0,388	0,950	-0,043	0,293	-0,098	0,238			0,062	0,435	12,492	1,527
NMIA	-0,210	0,501	-0,450	0,998	-0,105	0,426	-0,160	0,390	-0,062	0,435			12,430	1,557
VNIIM	-12,640	1,547	-12,880	1,772	-12,535	1,524	-12,590	1,514	-12,492	1,527	-12,430	1,557		
MIKES	-0,017	0,363	-0,257	0,937	0,088	0,249	0,033	0,181	0,131	0,264	0,193	0,406	12,623	1,519
VSL	-0,037	0,364	-0,277	0,937	0,068	0,250	0,013	0,183	0,111	0,265	0,173	0,407	12,603	1,519
GUM	-0,340	0,870	-0,580	1,226	-0,235	0,829	-0,290	0,811	-0,192	0,833	-0,130	0,889	12,300	1,712
INMETRO	-0,150	0,443	-0,390	0,971	-0,045	0,356	-0,100	0,312	-0,002	0,367	0,060	0,479	12,490	1,540
CENAM	-0,541	0,457	-0,781	0,977	-0,436	0,372	-0,491	0,331	-0,393	0,383	-0,331	0,491	12,099	1,544
CEM4	-0,104	0,342	-0,344	0,929	0,001	0,217	-0,054	0,134	0,044	0,234	0,106	0,387	12,536	1,514

Gauge 2	MIKES		VSL		GUM		INMETRO		CENAM		CEM4	
40 mm	$D_{ij} / \mu\text{m}$	$U_{ij} / \mu\text{m}$	$D_{ij} / \mu\text{m}$	$U_{ij} / \mu\text{m}$	$D_{ij} / \mu\text{m}$	$U_{ij} / \mu\text{m}$	$D_{ij} / \mu\text{m}$	$U_{ij} / \mu\text{m}$	$D_{ij} / \mu\text{m}$	$U_{ij} / \mu\text{m}$	$D_{ij} / \mu\text{m}$	$U_{ij} / \mu\text{m}$
BEV	-0,134	0,996	-0,114	0,996	0,189	1,271	-0,001	1,028	0,390	1,033	-0,047	0,988
NML	-0,087	2,161	-0,067	2,161	0,236	2,301	0,046	2,176	0,437	2,179	0,000	2,158
OMH	-0,123	0,882	-0,103	0,883	0,200	1,185	0,010	0,918	0,401	0,925	-0,036	0,874
SP	-0,207	0,208	-0,187	0,210	0,115	0,817	-0,075	0,329	0,316	0,347	-0,120	0,169
CEM2	-0,286	0,176	-0,266	0,178	0,037	0,810	-0,153	0,309	0,238	0,328	-0,199	0,127
CGM	-0,229	0,421	-0,210	0,422	0,093	0,896	-0,097	0,492	0,294	0,504	-0,143	0,403
CMI	-0,179	0,333	-0,160	0,334	0,143	0,857	-0,047	0,419	0,344	0,433	-0,093	0,310
LNE	0,017	0,363	0,037	0,364	0,340	0,870	0,150	0,443	0,541	0,457	0,104	0,342
INM	0,257	0,937	0,277	0,937	0,580	1,226	0,390	0,971	0,781	0,977	0,344	0,929
INRIM	-0,088	0,249	-0,068	0,250	0,235	0,829	0,045	0,356	0,436	0,372	-0,001	0,217
NPL	-0,033	0,181	-0,013	0,183	0,290	0,811	0,100	0,312	0,491	0,331	0,054	0,134
NRC	-0,131	0,264	-0,111	0,265	0,192	0,833	0,002	0,367	0,393	0,383	-0,044	0,234
NMIA	-0,193	0,406	-0,173	0,407	0,130	0,889	-0,060	0,479	0,331	0,491	-0,106	0,387
VNIIM	-12,623	1,519	-12,603	1,519	-12,300	1,712	-12,490	1,540	-12,099	1,544	-12,536	1,514
MIKES			0,020	0,215	0,323	0,819	0,133	0,332	0,523	0,350	0,087	0,176
VSL	-0,020	0,215			0,303	0,819	0,113	0,333	0,504	0,351	0,067	0,178
GUM	-0,323	0,819	-0,303	0,819			-0,190	0,857	0,201	0,864	-0,236	0,810
INMETRO	-0,133	0,332	-0,113	0,333	0,190	0,857			0,391	0,433	-0,046	0,309
CENAM	-0,523	0,350	-0,504	0,351	-0,201	0,864	-0,391	0,433			-0,437	0,328
CEM4	-0,087	0,176	-0,067	0,178	0,236	0,810	0,046	0,309	0,437	0,328		

Gauge 2	BEV		NML		OMH		SP		CEM2		CGM		CMI	
60 mm	$D_{ij} / \mu\text{m}$	$U_{ij} / \mu\text{m}$	$D_{ij} / \mu\text{m}$	$U_{ij} / \mu\text{m}$	$D_{ij} / \mu\text{m}$	$U_{ij} / \mu\text{m}$	$D_{ij} / \mu\text{m}$	$U_{ij} / \mu\text{m}$	$D_{ij} / \mu\text{m}$	$U_{ij} / \mu\text{m}$	$D_{ij} / \mu\text{m}$	$U_{ij} / \mu\text{m}$	$D_{ij} / \mu\text{m}$	$U_{ij} / \mu\text{m}$
BEV			-0,484	2,423	-0,197	1,412	-0,039	1,116	-0,009	1,110	-0,004	1,174	0,010	1,145
NML	0,484	2,423			0,288	2,328	0,445	2,161	0,475	2,158	0,480	2,192	0,495	2,177
OMH	0,197	1,412	-0,288	2,328			0,158	0,890	0,187	0,883	0,193	0,963	0,207	0,927
SP	0,039	1,116	-0,445	2,161	-0,158	0,890			0,030	0,175	0,035	0,422	0,049	0,334
CEM2	0,009	1,110	-0,475	2,158	-0,187	0,883	-0,030	0,175			0,005	0,405	0,020	0,313
CGM	0,004	1,174	-0,480	2,192	-0,193	0,963	-0,035	0,422	-0,005	0,405			0,015	0,495
CMI	-0,010	1,145	-0,495	2,177	-0,207	0,927	-0,049	0,334	-0,020	0,313	-0,015	0,495		
LNE	0,087	1,156	-0,398	2,182	-0,110	0,940	0,048	0,368	0,077	0,349	0,083	0,519	0,097	0,450
INM	-0,153	1,444	-0,638	2,348	-0,350	1,278	-0,192	0,941	-0,163	0,933	-0,157	1,009	-0,143	0,976
INRIM	0,228	1,124	-0,257	2,165	0,031	0,901	0,189	0,249	0,218	0,220	0,224	0,443	0,238	0,360
NPL	0,247	1,110	-0,238	2,158	0,050	0,884	0,208	0,180	0,237	0,137	0,243	0,408	0,257	0,316
NRC	0,046	1,127	-0,438	2,167	-0,150	0,905	0,007	0,263	0,037	0,236	0,042	0,451	0,057	0,370
NMIA	0,257	1,170	-0,228	2,190	0,060	0,958	0,218	0,410	0,247	0,393	0,253	0,549	0,267	0,485
VNIIM	-10,603	1,876	-11,088	2,635	-10,800	1,751	-10,642	1,522	-10,613	1,518	-10,607	1,566	-10,593	1,544
MIKES	0,209	1,116	-0,275	2,161	0,012	0,891	0,170	0,212	0,200	0,177	0,205	0,423	0,220	0,335
VSL	0,150	1,117	-0,335	2,162	-0,047	0,893	0,111	0,219	0,140	0,186	0,145	0,426	0,160	0,340
GUM	0,197	1,368	-0,288	2,302	0,000	1,192	0,158	0,820	0,187	0,811	0,193	0,898	0,207	0,860
INMETRO	0,147	1,145	-0,338	2,177	-0,050	0,927	0,108	0,333	0,137	0,312	0,143	0,495	0,157	0,422
CENAM	-0,391	1,150	-0,875	2,179	-0,588	0,933	-0,430	0,349	-0,401	0,329	-0,395	0,505	-0,381	0,435
CEM4	0,484	1,110	0,000	2,158	0,288	0,883	0,445	0,175	0,475	0,130	0,480	0,405	0,495	0,313

Gauge 2	LNE		INM		INRIM		NPL		NRC		NMIA		VNIIM	
60 mm	$D_{ij} / \mu\text{m}$	$U_{ij} / \mu\text{m}$	$D_{ij} / \mu\text{m}$	$U_{ij} / \mu\text{m}$	$D_{ij} / \mu\text{m}$	$U_{ij} / \mu\text{m}$	$D_{ij} / \mu\text{m}$	$U_{ij} / \mu\text{m}$	$D_{ij} / \mu\text{m}$	$U_{ij} / \mu\text{m}$	$D_{ij} / \mu\text{m}$	$U_{ij} / \mu\text{m}$	$D_{ij} / \mu\text{m}$	$U_{ij} / \mu\text{m}$
BEV	-0,087	1,156	0,153	1,444	-0,228	1,124	-0,247	1,110	-0,046	1,127	-0,257	1,170	10,603	1,876
NML	0,398	2,182	0,638	2,348	0,257	2,165	0,238	2,158	0,438	2,167	0,228	2,190	11,088	2,635
OMH	0,110	0,940	0,350	1,278	-0,031	0,901	-0,050	0,884	0,150	0,905	-0,060	0,958	10,800	1,751
SP	-0,048	0,368	0,192	0,941	-0,189	0,249	-0,208	0,180	-0,007	0,263	-0,218	0,410	10,642	1,522
CEM2	-0,077	0,349	0,163	0,933	-0,218	0,220	-0,237	0,137	-0,037	0,236	-0,247	0,393	10,613	1,518
CGM	-0,083	0,519	0,157	1,009	-0,224	0,443	-0,243	0,408	-0,042	0,451	-0,253	0,549	10,607	1,566
CMI	-0,097	0,450	0,143	0,976	-0,238	0,360	-0,257	0,316	-0,057	0,370	-0,267	0,485	10,593	1,544
LNE			0,240	0,988	-0,141	0,391	-0,160	0,351	0,040	0,400	-0,170	0,509	10,690	1,552
INM	-0,240	0,988			-0,381	0,950	-0,400	0,934	-0,200	0,954	-0,410	1,004	10,450	1,777
INRIM	0,141	0,391	0,381	0,950			-0,019	0,224	0,181	0,296	-0,029	0,431	10,831	1,528
NPL	0,160	0,351	0,400	0,934	0,019	0,224			0,200	0,240	-0,010	0,395	10,850	1,518
NRC	-0,040	0,400	0,200	0,954	-0,181	0,296	-0,200	0,240			-0,210	0,440	10,650	1,531
NMIA	0,170	0,509	0,410	1,004	0,029	0,431	0,010	0,395	0,210	0,440			10,860	1,563
VNIIM	-10,690	1,552	-10,450	1,777	-10,831	1,528	-10,850	1,518	-10,650	1,531	-10,860	1,563		
MIKES	0,122	0,369	0,362	0,941	-0,018	0,251	-0,038	0,182	0,163	0,265	-0,048	0,411	10,812	1,523
VSL	0,063	0,373	0,303	0,943	-0,078	0,257	-0,097	0,190	0,103	0,271	-0,107	0,415	10,753	1,524
GUM	0,110	0,873	0,350	1,230	-0,031	0,831	-0,050	0,812	0,150	0,835	-0,060	0,892	10,800	1,716
INMETRO	0,060	0,449	0,300	0,975	-0,081	0,359	-0,100	0,315	0,100	0,369	-0,110	0,485	10,750	1,544
CENAM	-0,478	0,461	-0,238	0,981	-0,619	0,374	-0,638	0,331	-0,437	0,383	-0,648	0,496	10,212	1,548
CEM4	0,398	0,349	0,638	0,933	0,257	0,220	0,238	0,137	0,438	0,236	0,228	0,393	11,088	1,518

Gauge 2	MIKES		VSL		GUM		INMETRO		CENAM		CEM4	
60 mm	$D_{ij} / \mu\text{m}$	$U_{ij} / \mu\text{m}$	$D_{ij} / \mu\text{m}$	$U_{ij} / \mu\text{m}$	$D_{ij} / \mu\text{m}$	$U_{ij} / \mu\text{m}$	$D_{ij} / \mu\text{m}$	$U_{ij} / \mu\text{m}$	$D_{ij} / \mu\text{m}$	$U_{ij} / \mu\text{m}$	$D_{ij} / \mu\text{m}$	$U_{ij} / \mu\text{m}$
BEV	-0,209	1,116	-0,150	1,117	-0,197	1,368	-0,147	1,145	0,391	1,150	-0,484	1,110
NML	0,275	2,161	0,335	2,162	0,288	2,302	0,338	2,177	0,875	2,179	0,000	2,158
OMH	-0,012	0,891	0,047	0,893	0,000	1,192	0,050	0,927	0,588	0,933	-0,288	0,883
SP	-0,170	0,212	-0,111	0,219	-0,158	0,820	-0,108	0,333	0,430	0,349	-0,445	0,175
CEM2	-0,200	0,177	-0,140	0,186	-0,187	0,811	-0,137	0,312	0,401	0,329	-0,475	0,130
CGM	-0,205	0,423	-0,145	0,426	-0,193	0,898	-0,143	0,495	0,395	0,505	-0,480	0,405
CMI	-0,220	0,335	-0,160	0,340	-0,207	0,860	-0,157	0,422	0,381	0,435	-0,495	0,313
LNE	-0,122	0,369	-0,063	0,373	-0,110	0,873	-0,060	0,449	0,478	0,461	-0,398	0,349
INM	-0,362	0,941	-0,303	0,943	-0,350	1,230	-0,300	0,975	0,238	0,981	-0,638	0,933
INRIM	0,018	0,251	0,078	0,257	0,031	0,831	0,081	0,359	0,619	0,374	-0,257	0,220
NPL	0,038	0,182	0,097	0,190	0,050	0,812	0,100	0,315	0,638	0,331	-0,238	0,137
NRC	-0,163	0,265	-0,103	0,271	-0,150	0,835	-0,100	0,369	0,437	0,383	-0,438	0,236
NMIA	0,048	0,411	0,107	0,415	0,060	0,892	0,110	0,485	0,648	0,496	-0,228	0,393
VNIIM	-10,812	1,523	-10,753	1,524	-10,800	1,716	-10,750	1,544	-10,212	1,548	-11,088	1,518
MIKES			0,060	0,221	0,012	0,820	0,062	0,334	0,600	0,350	-0,275	0,177
VSL	-0,060	0,221			-0,047	0,822	0,003	0,339	0,541	0,354	-0,335	0,186
GUM	-0,012	0,820	0,047	0,822			0,050	0,859	0,588	0,866	-0,288	0,811
INMETRO	-0,062	0,334	-0,003	0,339	-0,050	0,859			0,538	0,434	-0,338	0,312
CENAM	-0,600	0,350	-0,541	0,354	-0,588	0,866	-0,538	0,434			-0,875	0,329
CEM4	0,275	0,177	0,335	0,186	0,288	0,811	0,338	0,312	0,875	0,329		

Gauge 3	BEV		NML		OMH		SP		CEM2		CGM		CMI	
80 mm	$D_{ij} / \mu\text{m}$	$U_{ij} / \mu\text{m}$	$D_{ij} / \mu\text{m}$	$U_{ij} / \mu\text{m}$	$D_{ij} / \mu\text{m}$	$U_{ij} / \mu\text{m}$	$D_{ij} / \mu\text{m}$	$U_{ij} / \mu\text{m}$	$D_{ij} / \mu\text{m}$	$U_{ij} / \mu\text{m}$	$D_{ij} / \mu\text{m}$	$U_{ij} / \mu\text{m}$	$D_{ij} / \mu\text{m}$	$U_{ij} / \mu\text{m}$
BEV			0,242	2,375	-0,001	1,336	0,239	1,008	0,184	1,001	0,278	1,072	0,190	1,041
NML	-0,242	2,375			-0,243	2,332	-0,003	2,162	-0,058	2,158	0,036	2,192	-0,052	2,177
OMH	0,001	1,336	0,243	2,332			0,240	0,903	0,185	0,895	0,279	0,974	0,191	0,940
SP	-0,239	1,008	0,003	2,162	-0,240	0,903			-0,055	0,181	0,039	0,426	-0,049	0,339
CEM2	-0,184	1,001	0,058	2,158	-0,185	0,895	0,055	0,181			0,094	0,408	0,006	0,317
CGM	-0,278	1,072	-0,036	2,192	-0,279	0,974	-0,039	0,426	-0,094	0,408			-0,088	0,499
CMI	-0,190	1,041	0,052	2,177	-0,191	0,940	0,049	0,339	-0,006	0,317	0,088	0,499		
LNE	0,041	1,054	0,283	2,183	0,040	0,954	0,280	0,377	0,225	0,357	0,319	0,526	0,231	0,459
INM	0,501	1,366	0,743	2,350	0,500	1,290	0,740	0,947	0,685	0,939	0,779	1,015	0,691	0,982
INRIM	-0,176	1,017	0,067	2,166	-0,177	0,913	0,063	0,255	0,008	0,225	0,103	0,446	0,015	0,365
NPL	-0,059	1,002	0,183	2,159	-0,060	0,896	0,180	0,185	0,125	0,140	0,219	0,410	0,131	0,320
NRC	-0,208	1,020	0,034	2,167	-0,209	0,916	0,031	0,267	-0,024	0,239	0,070	0,453	-0,018	0,374
NMIA	-0,259	1,070	-0,017	2,191	-0,260	0,971	-0,020	0,419	-0,075	0,401	0,019	0,556	-0,069	0,493
VNIIM	-2,499	1,818	-2,257	2,638	-2,500	1,762	-2,260	1,528	-2,315	1,523	-2,221	1,571	-2,309	1,550
MIKES	-0,047	1,008	0,195	2,161	-0,048	0,903	0,192	0,216	0,137	0,179	0,231	0,425	0,143	0,339
VSL	-0,145	1,011	0,098	2,163	-0,146	0,906	0,094	0,230	0,039	0,196	0,134	0,432	0,046	0,348
GUM	-0,499	1,283	-0,257	2,302	-0,500	1,202	-0,260	0,822	-0,315	0,813	-0,221	0,900	-0,309	0,863
INMETRO	-0,129	1,041	0,113	2,177	-0,130	0,940	0,110	0,339	0,055	0,316	0,149	0,499	0,061	0,427
CENAM	-0,274	1,046	-0,032	2,179	-0,275	0,945	-0,035	0,353	-0,090	0,331	0,004	0,508	-0,084	0,439
CEM4	-0,242	1,001	0,000	2,158	-0,243	0,895	-0,003	0,181	-0,058	0,134	0,036	0,408	-0,052	0,317

Gauge 3	LNE		INM		INRIM		NPL		NRC		NMIA		VNIIM	
80 mm	$D_{ij} / \mu\text{m}$	$U_{ij} / \mu\text{m}$	$D_{ij} / \mu\text{m}$	$U_{ij} / \mu\text{m}$	$D_{ij} / \mu\text{m}$	$U_{ij} / \mu\text{m}$	$D_{ij} / \mu\text{m}$	$U_{ij} / \mu\text{m}$	$D_{ij} / \mu\text{m}$	$U_{ij} / \mu\text{m}$	$D_{ij} / \mu\text{m}$	$U_{ij} / \mu\text{m}$	$D_{ij} / \mu\text{m}$	$U_{ij} / \mu\text{m}$
BEV	-0,041	1,054	-0,501	1,366	0,176	1,017	0,059	1,002	0,208	1,020	0,259	1,070	2,499	1,818
NML	-0,283	2,183	-0,743	2,350	-0,067	2,166	-0,183	2,159	-0,034	2,167	0,017	2,191	2,257	2,638
OMH	-0,040	0,954	-0,500	1,290	0,177	0,913	0,060	0,896	0,209	0,916	0,260	0,971	2,500	1,762
SP	-0,280	0,377	-0,740	0,947	-0,063	0,255	-0,180	0,185	-0,031	0,267	0,020	0,419	2,260	1,528
CEM2	-0,225	0,357	-0,685	0,939	-0,008	0,225	-0,125	0,140	0,024	0,239	0,075	0,401	2,315	1,523
CGM	-0,319	0,526	-0,779	1,015	-0,103	0,446	-0,219	0,410	-0,070	0,453	-0,019	0,556	2,221	1,571
CMI	-0,231	0,459	-0,691	0,982	-0,015	0,365	-0,131	0,320	0,018	0,374	0,069	0,493	2,309	1,550
LNE			-0,460	0,996	0,217	0,400	0,100	0,360	0,249	0,408	0,300	0,520	2,540	1,559
INM	0,460	0,996			0,677	0,956	0,560	0,940	0,709	0,960	0,760	1,012	3,000	1,785
INRIM	-0,217	0,400	-0,677	0,956			-0,117	0,228	0,032	0,299	0,083	0,440	2,323	1,534
NPL	-0,100	0,360	-0,560	0,940	0,117	0,228			0,149	0,242	0,200	0,403	2,440	1,524
NRC	-0,249	0,408	-0,709	0,960	-0,032	0,299	-0,149	0,242			0,051	0,447	2,291	1,536
NMIA	-0,300	0,520	-0,760	1,012	-0,083	0,440	-0,200	0,403	-0,051	0,447			2,240	1,569
VNIIM	-2,540	1,559	-3,000	1,785	-2,323	1,534	-2,440	1,524	-2,291	1,536	-2,240	1,569		
MIKES	-0,088	0,377	-0,548	0,947	0,128	0,254	0,012	0,184	0,161	0,267	0,212	0,418	2,452	1,528
VSL	-0,186	0,385	-0,646	0,950	0,031	0,266	-0,086	0,200	0,063	0,278	0,114	0,426	2,354	1,530
GUM	-0,540	0,878	-1,000	1,235	-0,323	0,833	-0,440	0,814	-0,291	0,837	-0,240	0,897	2,000	1,722
INMETRO	-0,170	0,458	-0,630	0,982	0,047	0,364	-0,070	0,319	0,079	0,373	0,130	0,493	2,370	1,550
CENAM	-0,315	0,468	-0,775	0,987	-0,098	0,377	-0,215	0,334	-0,066	0,386	-0,015	0,503	2,225	1,553
CEM4	-0,283	0,357	-0,743	0,939	-0,067	0,225	-0,183	0,140	-0,034	0,239	0,017	0,401	2,257	1,523

Gauge 3	MIKES		VSL		GUM		INMETRO		CENAM		CEM4	
80 mm	$D_{ij} / \mu\text{m}$	$U_{ij} / \mu\text{m}$	$D_{ij} / \mu\text{m}$	$U_{ij} / \mu\text{m}$	$D_{ij} / \mu\text{m}$	$U_{ij} / \mu\text{m}$	$D_{ij} / \mu\text{m}$	$U_{ij} / \mu\text{m}$	$D_{ij} / \mu\text{m}$	$U_{ij} / \mu\text{m}$	$D_{ij} / \mu\text{m}$	$U_{ij} / \mu\text{m}$
BEV	0,047	1,008	0,145	1,011	0,499	1,283	0,129	1,041	0,274	1,046	0,242	1,001
NML	-0,195	2,161	-0,098	2,163	0,257	2,302	-0,113	2,177	0,032	2,179	0,000	2,158
OMH	0,048	0,903	0,146	0,906	0,500	1,202	0,130	0,940	0,275	0,945	0,243	0,895
SP	-0,192	0,216	-0,094	0,230	0,260	0,822	-0,110	0,339	0,035	0,353	0,003	0,181
CEM2	-0,137	0,179	-0,039	0,196	0,315	0,813	-0,055	0,316	0,090	0,331	0,058	0,134
CGM	-0,231	0,425	-0,134	0,432	0,221	0,900	-0,149	0,499	-0,004	0,508	-0,036	0,408
CMI	-0,143	0,339	-0,046	0,348	0,309	0,863	-0,061	0,427	0,084	0,439	0,052	0,317
LNE	0,088	0,377	0,186	0,385	0,540	0,878	0,170	0,458	0,315	0,468	0,283	0,357
INM	0,548	0,947	0,646	0,950	1,000	1,235	0,630	0,982	0,775	0,987	0,743	0,939
INRIM	-0,128	0,254	-0,031	0,266	0,323	0,833	-0,047	0,364	0,098	0,377	0,067	0,225
NPL	-0,012	0,184	0,086	0,200	0,440	0,814	0,070	0,319	0,215	0,334	0,183	0,140
NRC	-0,161	0,267	-0,063	0,278	0,291	0,837	-0,079	0,373	0,066	0,386	0,034	0,239
NMIA	-0,212	0,418	-0,114	0,426	0,240	0,897	-0,130	0,493	0,015	0,503	-0,017	0,401
VNIIM	-2,452	1,528	-2,354	1,530	-2,000	1,722	-2,370	1,550	-2,225	1,553	-2,257	1,523
MIKES			0,097	0,229	0,452	0,822	0,082	0,338	0,227	0,352	0,195	0,179
VSL	-0,097	0,229			0,354	0,826	-0,016	0,347	0,129	0,361	0,098	0,196
GUM	-0,452	0,822	-0,354	0,826			-0,370	0,862	-0,225	0,868	-0,257	0,813
INMETRO	-0,082	0,338	0,016	0,347	0,370	0,862			0,145	0,438	0,113	0,316
CENAM	-0,227	0,352	-0,129	0,361	0,225	0,868	-0,145	0,438			-0,032	0,331
CEM4	-0,195	0,179	-0,098	0,196	0,257	0,813	-0,113	0,316	0,032	0,331		

Gauge 3	BEV		NML		OMH		SP		CEM2		CGM		CMI	
100 mm	$D_{ij} / \mu\text{m}$	$U_{ij} / \mu\text{m}$	$D_{ij} / \mu\text{m}$	$U_{ij} / \mu\text{m}$	$D_{ij} / \mu\text{m}$	$U_{ij} / \mu\text{m}$	$D_{ij} / \mu\text{m}$	$U_{ij} / \mu\text{m}$	$D_{ij} / \mu\text{m}$	$U_{ij} / \mu\text{m}$	$D_{ij} / \mu\text{m}$	$U_{ij} / \mu\text{m}$	$D_{ij} / \mu\text{m}$	$U_{ij} / \mu\text{m}$
BEV			-0,577	2,430	-1,444	1,440	-0,165	1,131	-0,272	1,124	-0,235	1,189	-0,151	1,162
NML	0,577	2,430			-0,867	2,338	0,412	2,162	0,305	2,158	0,342	2,193	0,425	2,178
OMH	1,444	1,440	0,867	2,338			1,279	0,919	1,173	0,910	1,209	0,989	1,293	0,956
SP	0,165	1,131	-0,412	2,162	-1,279	0,919			-0,106	0,187	-0,070	0,430	0,014	0,346
CEM2	0,272	1,124	-0,305	2,158	-1,173	0,910	0,106	0,187			0,037	0,412	0,120	0,323
CGM	0,235	1,189	-0,342	2,193	-1,209	0,989	0,070	0,430	-0,037	0,412			0,084	0,504
CMI	0,151	1,162	-0,425	2,178	-1,293	0,956	-0,014	0,346	-0,120	0,323	-0,084	0,504		
LNE	0,234	1,175	-0,343	2,185	-1,210	0,972	0,069	0,389	-0,037	0,368	-0,001	0,534	0,083	0,469
INM	0,014	1,463	-0,563	2,353	-1,430	1,306	-0,151	0,955	-0,257	0,947	-0,221	1,023	-0,137	0,991
INRIM	0,292	1,139	-0,285	2,166	-1,153	0,929	0,127	0,261	0,020	0,230	0,057	0,450	0,140	0,371
NPL	0,384	1,125	-0,193	2,159	-1,060	0,911	0,219	0,191	0,113	0,145	0,149	0,414	0,233	0,325
NRC	0,195	1,142	-0,382	2,167	-1,250	0,932	0,030	0,272	-0,077	0,242	-0,040	0,457	0,043	0,379
NMIA	0,454	1,189	-0,123	2,193	-0,990	0,989	0,289	0,429	0,183	0,411	0,219	0,565	0,303	0,504
VNIIM	-0,856	1,893	-1,433	2,642	-2,300	1,775	-1,021	1,535	-1,127	1,530	-1,091	1,578	-1,007	1,557
MIKES	0,326	1,131	-0,251	2,161	-1,118	0,918	0,161	0,220	0,054	0,182	0,091	0,428	0,175	0,343
VSL	0,243	1,135	-0,334	2,164	-1,201	0,923	0,078	0,243	-0,029	0,208	0,008	0,440	0,092	0,358
GUM	0,844	1,382	0,267	2,303	-0,600	1,215	0,679	0,826	0,573	0,816	0,609	0,904	0,693	0,867
INMETRO	0,284	1,161	-0,293	2,178	-1,160	0,955	0,119	0,345	0,013	0,321	0,049	0,503	0,133	0,434
CENAM	0,132	1,164	-0,444	2,179	-1,312	0,959	-0,033	0,355	-0,139	0,332	-0,103	0,511	-0,019	0,442
CEM4	0,577	1,124	0,000	2,158	-0,867	0,910	0,412	0,187	0,305	0,139	0,342	0,412	0,425	0,323

Gauge 3	LNE		INM		INRIM		NPL		NRC		NMIA		VNIIM	
100 mm	$D_{ij} / \mu\text{m}$	$U_{ij} / \mu\text{m}$	$D_{ij} / \mu\text{m}$	$U_{ij} / \mu\text{m}$	$D_{ij} / \mu\text{m}$	$U_{ij} / \mu\text{m}$	$D_{ij} / \mu\text{m}$	$U_{ij} / \mu\text{m}$	$D_{ij} / \mu\text{m}$	$U_{ij} / \mu\text{m}$	$D_{ij} / \mu\text{m}$	$U_{ij} / \mu\text{m}$	$D_{ij} / \mu\text{m}$	$U_{ij} / \mu\text{m}$
BEV	-0,234	1,175	-0,014	1,463	-0,292	1,139	-0,384	1,125	-0,195	1,142	-0,454	1,189	0,856	1,893
NML	0,343	2,185	0,563	2,353	0,285	2,166	0,193	2,159	0,382	2,167	0,123	2,193	1,433	2,642
OMH	1,210	0,972	1,430	1,306	1,153	0,929	1,060	0,911	1,250	0,932	0,990	0,989	2,300	1,775
SP	-0,069	0,389	0,151	0,955	-0,127	0,261	-0,219	0,191	-0,030	0,272	-0,289	0,429	1,021	1,535
CEM2	0,037	0,368	0,257	0,947	-0,020	0,230	-0,113	0,145	0,077	0,242	-0,183	0,411	1,127	1,530
CGM	0,001	0,534	0,221	1,023	-0,057	0,450	-0,149	0,414	0,040	0,457	-0,219	0,565	1,091	1,578
CMI	-0,083	0,469	0,137	0,991	-0,140	0,371	-0,233	0,325	-0,043	0,379	-0,303	0,504	1,007	1,557
LNE			0,220	1,006	-0,057	0,411	-0,150	0,370	0,040	0,418	-0,220	0,534	1,090	1,567
INM	-0,220	1,006			-0,277	0,964	-0,370	0,948	-0,180	0,967	-0,440	1,023	0,870	1,794
INRIM	0,057	0,411	0,277	0,964			-0,093	0,233	0,097	0,303	-0,163	0,450	1,147	1,541
NPL	0,150	0,370	0,370	0,948	0,093	0,233			0,190	0,245	-0,070	0,413	1,240	1,530
NRC	-0,040	0,418	0,180	0,967	-0,097	0,303	-0,190	0,245			-0,260	0,456	1,050	1,542
NMIA	0,220	0,534	0,440	1,023	0,163	0,450	0,070	0,413	0,260	0,456			1,310	1,578
VNIIM	-1,090	1,567	-0,870	1,794	-1,147	1,541	-1,240	1,530	-1,050	1,542	-1,310	1,578		
MIKES	0,092	0,386	0,312	0,954	0,034	0,258	-0,058	0,186	0,131	0,268	-0,128	0,427	1,182	1,534
VSL	0,009	0,399	0,229	0,960	-0,049	0,277	-0,141	0,212	0,048	0,287	-0,211	0,439	1,099	1,538
GUM	0,610	0,885	0,830	1,242	0,553	0,836	0,460	0,817	0,650	0,840	0,390	0,903	1,700	1,728
INMETRO	0,050	0,468	0,270	0,990	-0,007	0,370	-0,100	0,324	0,090	0,377	-0,170	0,503	1,140	1,557
CENAM	-0,102	0,476	0,118	0,994	-0,159	0,379	-0,252	0,335	-0,062	0,387	-0,322	0,510	0,988	1,559
CEM4	0,343	0,368	0,563	0,947	0,285	0,230	0,193	0,145	0,382	0,242	0,123	0,411	1,433	1,530

Gauge 3	MIKES		VSL		GUM		INMETRO		CENAM		CEM4	
100 mm	$D_{ij} / \mu\text{m}$	$U_{ij} / \mu\text{m}$	$D_{ij} / \mu\text{m}$	$U_{ij} / \mu\text{m}$	$D_{ij} / \mu\text{m}$	$U_{ij} / \mu\text{m}$	$D_{ij} / \mu\text{m}$	$U_{ij} / \mu\text{m}$	$D_{ij} / \mu\text{m}$	$U_{ij} / \mu\text{m}$	$D_{ij} / \mu\text{m}$	$U_{ij} / \mu\text{m}$
BEV	-0,326	1,131	-0,243	1,135	-0,844	1,382	-0,284	1,161	-0,132	1,164	-0,577	1,124
NML	0,251	2,161	0,334	2,164	-0,267	2,303	0,293	2,178	0,444	2,179	0,000	2,158
OMH	1,118	0,918	1,201	0,923	0,600	1,215	1,160	0,955	1,312	0,959	0,867	0,910
SP	-0,161	0,220	-0,078	0,243	-0,679	0,826	-0,119	0,345	0,033	0,355	-0,412	0,187
CEM2	-0,054	0,182	0,029	0,208	-0,573	0,816	-0,013	0,321	0,139	0,332	-0,305	0,139
CGM	-0,091	0,428	-0,008	0,440	-0,609	0,904	-0,049	0,503	0,103	0,511	-0,342	0,412
CMI	-0,175	0,343	-0,092	0,358	-0,693	0,867	-0,133	0,434	0,019	0,442	-0,425	0,323
LNE	-0,092	0,386	-0,009	0,399	-0,610	0,885	-0,050	0,468	0,102	0,476	-0,343	0,368
INM	-0,312	0,954	-0,229	0,960	-0,830	1,242	-0,270	0,990	-0,118	0,994	-0,563	0,947
INRIM	-0,034	0,258	0,049	0,277	-0,553	0,836	0,007	0,370	0,159	0,379	-0,285	0,230
NPL	0,058	0,186	0,141	0,212	-0,460	0,817	0,100	0,324	0,252	0,335	-0,193	0,145
NRC	-0,131	0,268	-0,048	0,287	-0,650	0,840	-0,090	0,377	0,062	0,387	-0,382	0,242
NMIA	0,128	0,427	0,211	0,439	-0,390	0,903	0,170	0,503	0,322	0,510	-0,123	0,411
VNIIM	-1,182	1,534	-1,099	1,538	-1,700	1,728	-1,140	1,557	-0,988	1,559	-1,433	1,530
MIKES			0,083	0,239	-0,518	0,825	0,042	0,342	0,194	0,352	-0,251	0,182
VSL	-0,083	0,239			-0,601	0,831	-0,041	0,357	0,111	0,367	-0,334	0,208
GUM	0,518	0,825	0,601	0,831			0,560	0,866	0,712	0,870	0,267	0,816
INMETRO	-0,042	0,342	0,041	0,357	-0,560	0,866			0,152	0,441	-0,293	0,321
CENAM	-0,194	0,352	-0,111	0,367	-0,712	0,870	-0,152	0,441			-0,444	0,332
CEM4	0,251	0,182	0,334	0,208	-0,267	0,816	0,293	0,321	0,444	0,332		

Gauge 4	BEV		NML		OMH		SP		CEM2		CGM		CMI	
120 mm	$D_{ij} / \mu\text{m}$	$U_{ij} / \mu\text{m}$	$D_{ij} / \mu\text{m}$	$U_{ij} / \mu\text{m}$	$D_{ij} / \mu\text{m}$	$U_{ij} / \mu\text{m}$	$D_{ij} / \mu\text{m}$	$U_{ij} / \mu\text{m}$	$D_{ij} / \mu\text{m}$	$U_{ij} / \mu\text{m}$	$D_{ij} / \mu\text{m}$	$U_{ij} / \mu\text{m}$	$D_{ij} / \mu\text{m}$	$U_{ij} / \mu\text{m}$
BEV			0,468	2,383	-0,384	1,373	0,397	1,029	0,227	1,021	0,350	1,093	0,310	1,063
NML	-0,468	2,383			-0,853	2,345	-0,071	2,162	-0,241	2,158	-0,119	2,193	-0,158	2,179
OMH	0,384	1,373	0,853	2,345			0,782	0,938	0,612	0,929	0,734	1,007	0,694	0,975
SP	-0,397	1,029	0,071	2,162	-0,782	0,938			-0,170	0,193	-0,048	0,435	-0,087	0,354
CEM2	-0,227	1,021	0,241	2,158	-0,612	0,929	0,170	0,193			0,122	0,416	0,083	0,330
CGM	-0,350	1,093	0,119	2,193	-0,734	1,007	0,048	0,435	-0,122	0,416			-0,040	0,511
CMI	-0,310	1,063	0,158	2,179	-0,694	0,975	0,087	0,354	-0,083	0,330	0,040	0,511		
LNE	-0,026	1,080	0,443	2,187	-0,410	0,993	0,372	0,402	0,202	0,381	0,324	0,545	0,284	0,482
INM	0,514	1,392	0,983	2,356	0,130	1,325	0,912	0,965	0,742	0,956	0,864	1,033	0,824	1,001
INRIM	-0,325	1,038	0,143	2,166	-0,709	0,947	0,073	0,268	-0,097	0,236	0,025	0,456	-0,015	0,379
NPL	-0,226	1,022	0,242	2,159	-0,610	0,930	0,172	0,197	0,002	0,150	0,124	0,418	0,084	0,332
NRC	-0,283	1,040	0,185	2,168	-0,667	0,950	0,115	0,277	-0,056	0,245	0,067	0,461	0,027	0,384
NMIA	-0,266	1,096	0,203	2,195	-0,650	1,010	0,132	0,442	-0,038	0,423	0,084	0,575	0,044	0,516
VNIIM	12,084	1,840	12,552	2,646	11,700	1,790	12,482	1,543	12,312	1,538	12,434	1,586	12,394	1,566
MIKES	-0,121	1,028	0,347	2,162	-0,505	0,936	0,277	0,225	0,107	0,185	0,229	0,431	0,189	0,349
VSL	-0,250	1,035	0,218	2,165	-0,634	0,944	0,147	0,257	-0,023	0,223	0,100	0,449	0,060	0,370
GUM	-0,616	1,301	-0,147	2,304	-1,000	1,230	-0,218	0,830	-0,388	0,820	-0,266	0,908	-0,306	0,871
INMETRO	-0,226	1,062	0,242	2,178	-0,610	0,974	0,172	0,350	0,002	0,326	0,124	0,508	0,084	0,441
CENAM	-0,816	1,065	-0,348	2,180	-1,201	0,977	-0,419	0,359	-0,589	0,336	-0,467	0,514	-0,506	0,447
CEM4	-0,468	1,021	0,000	2,158	-0,853	0,929	-0,071	0,193	-0,241	0,145	-0,119	0,416	-0,158	0,330

Gauge 4	LNE		INM		INRIM		NPL		NRC		NMIA		VNIIM		
120 mm	$D_{ij} / \mu\text{m}$	$U_{ij} / \mu\text{m}$	$D_{ij} / \mu\text{m}$	$U_{ij} / \mu\text{m}$	$D_{ij} / \mu\text{m}$	$U_{ij} / \mu\text{m}$	$D_{ij} / \mu\text{m}$	$U_{ij} / \mu\text{m}$	$D_{ij} / \mu\text{m}$	$U_{ij} / \mu\text{m}$	$D_{ij} / \mu\text{m}$	$U_{ij} / \mu\text{m}$	$D_{ij} / \mu\text{m}$	$U_{ij} / \mu\text{m}$	
BEV	0,026	1,080	-0,514	1,392	0,325	1,038	0,226	1,022	0,283	1,040	0,266	1,096	-12,084	1,840	
NML	-0,443	2,187	-0,983	2,356	-0,143	2,166	-0,242	2,159	-0,185	2,168	-0,203	2,195	-12,552	2,646	
OMH	0,410	0,993	-0,130	1,325	0,709	0,947	0,610	0,930	0,667	0,950	0,650	1,010	-11,700	1,790	
SP	-0,372	0,402	-0,912	0,965	-0,073	0,268	-0,172	0,197	-0,115	0,277	-0,132	0,442	-12,482	1,543	
CEM2	-0,202	0,381	-0,742	0,956	0,097	0,236	-0,002	0,150	0,056	0,245	0,038	0,423	-12,312	1,538	
CGM	-0,324	0,545	-0,864	1,033	-0,025	0,456	-0,124	0,418	-0,067	0,461	-0,084	0,575	-12,434	1,586	
CMI	-0,284	0,482	-0,824	1,001	0,015	0,379	-0,084	0,332	-0,027	0,384	-0,044	0,516	-12,394	1,566	
LNE			-0,540	1,019		0,299	0,424	0,200	0,383	0,257	0,429	0,240	0,550	-12,110	1,577
INM	0,540	1,019			0,839	0,974	0,740	0,957	0,797	0,977	0,780	1,035	-11,570	1,805	
INRIM	-0,299	0,424	-0,839	0,974			-0,099	0,239	-0,042	0,308	-0,059	0,462	-12,409	1,549	
NPL	-0,200	0,383	-0,740	0,957	0,099	0,239			0,057	0,248	0,040	0,424	-12,310	1,538	
NRC	-0,257	0,429	-0,797	0,977	0,042	0,308	-0,057	0,248			-0,017	0,467	-12,367	1,550	
NMIA	-0,240	0,550	-0,780	1,035	0,059	0,462	-0,040	0,424	0,017	0,467			-12,350	1,588	
VNIIM	12,110	1,577	11,570	1,805	12,409	1,549	12,310	1,538	12,367	1,550	12,350	1,588			
MIKES	-0,095	0,398	-0,635	0,963	0,204	0,262	0,105	0,189	0,162	0,271	0,145	0,438	-12,205	1,542	
VSL	-0,224	0,417	-0,764	0,971	0,075	0,290	-0,024	0,226	0,033	0,298	0,016	0,455	-12,334	1,547	
GUM	-0,590	0,892	-1,130	1,251	-0,291	0,841	-0,390	0,821	-0,333	0,843	-0,350	0,911	-12,700	1,736	
INMETRO	-0,200	0,480	-0,740	1,000	0,099	0,376	0,000	0,328	0,057	0,382	0,040	0,514	-12,310	1,565	
CENAM	-0,791	0,486	-1,331	1,003	-0,492	0,384	-0,591	0,338	-0,533	0,390	-0,551	0,520	-12,901	1,567	
CEM4	-0,443	0,381	-0,983	0,956	-0,143	0,236	-0,242	0,150	-0,185	0,245	-0,203	0,423	-12,552	1,538	

Gauge 4	MIKES		VSL		GUM		INMETRO		CENAM		CEM4	
120 mm	$D_{ij} / \mu\text{m}$	$U_{ij} / \mu\text{m}$	$D_{ij} / \mu\text{m}$	$U_{ij} / \mu\text{m}$	$D_{ij} / \mu\text{m}$	$U_{ij} / \mu\text{m}$	$D_{ij} / \mu\text{m}$	$U_{ij} / \mu\text{m}$	$D_{ij} / \mu\text{m}$	$U_{ij} / \mu\text{m}$	$D_{ij} / \mu\text{m}$	$U_{ij} / \mu\text{m}$
BEV	0,121	1,028	0,250	1,035	0,616	1,301	0,226	1,062	0,816	1,065	0,468	1,021
NML	-0,347	2,162	-0,218	2,165	0,147	2,304	-0,242	2,178	0,348	2,180	0,000	2,158
OMH	0,505	0,936	0,634	0,944	1,000	1,230	0,610	0,974	1,201	0,977	0,853	0,929
SP	-0,277	0,225	-0,147	0,257	0,218	0,830	-0,172	0,350	0,419	0,359	0,071	0,193
CEM2	-0,107	0,185	0,023	0,223	0,388	0,820	-0,002	0,326	0,589	0,336	0,241	0,145
CGM	-0,229	0,431	-0,100	0,449	0,266	0,908	-0,124	0,508	0,467	0,514	0,119	0,416
CMI	-0,189	0,349	-0,060	0,370	0,306	0,871	-0,084	0,441	0,506	0,447	0,158	0,330
LNE	0,095	0,398	0,224	0,417	0,590	0,892	0,200	0,480	0,791	0,486	0,443	0,381
INM	0,635	0,963	0,764	0,971	1,130	1,251	0,740	1,000	1,331	1,003	0,983	0,956
INRIM	-0,204	0,262	-0,075	0,290	0,291	0,841	-0,099	0,376	0,492	0,384	0,143	0,236
NPL	-0,105	0,189	0,024	0,226	0,390	0,821	0,000	0,328	0,591	0,338	0,242	0,150
NRC	-0,162	0,271	-0,033	0,298	0,333	0,843	-0,057	0,382	0,533	0,390	0,185	0,245
NMIA	-0,145	0,438	-0,016	0,455	0,350	0,911	-0,040	0,514	0,551	0,520	0,203	0,423
VNIIM	12,205	1,542	12,334	1,547	12,700	1,736	12,310	1,565	12,901	1,567	12,552	1,538
MIKES			0,129	0,250	0,495	0,828	0,105	0,346	0,696	0,355	0,347	0,185
VSL	-0,129	0,250			0,366	0,837	-0,024	0,367	0,566	0,376	0,218	0,223
GUM	-0,495	0,828	-0,366	0,837			-0,390	0,870	0,201	0,874	-0,147	0,820
INMETRO	-0,105	0,346	0,024	0,367	0,390	0,870			0,591	0,445	0,242	0,326
CENAM	-0,696	0,355	-0,566	0,376	-0,201	0,874	-0,591	0,445			-0,348	0,336
CEM4	-0,347	0,185	-0,218	0,223	0,147	0,820	-0,242	0,326	0,348	0,336		

Gauge 4	BEV		NML		OMH		SP		CEM2		CGM		CMI	
140 mm	$D_{ij} / \mu\text{m}$	$U_{ij} / \mu\text{m}$	$D_{ij} / \mu\text{m}$	$U_{ij} / \mu\text{m}$	$D_{ij} / \mu\text{m}$	$U_{ij} / \mu\text{m}$	$D_{ij} / \mu\text{m}$	$U_{ij} / \mu\text{m}$	$D_{ij} / \mu\text{m}$	$U_{ij} / \mu\text{m}$	$D_{ij} / \mu\text{m}$	$U_{ij} / \mu\text{m}$	$D_{ij} / \mu\text{m}$	$U_{ij} / \mu\text{m}$
BEV			-0,353	2,439	-0,958	1,481	-0,110	1,154	-0,344	1,146	-0,202	1,212	-0,115	1,185
NML	0,353	2,439			-0,604	2,354	0,243	2,163	0,010	2,159	0,152	2,194	0,239	2,180
OMH	0,958	1,481	0,604	2,354			0,847	0,959	0,614	0,950	0,756	1,028	0,843	0,997
SP	0,110	1,154	-0,243	2,163	-0,847	0,959			-0,233	0,200	-0,091	0,441	-0,004	0,362
CEM2	0,344	1,146	-0,010	2,159	-0,614	0,950	0,233	0,200			0,142	0,421	0,229	0,338
CGM	0,202	1,212	-0,152	2,194	-0,756	1,028	0,091	0,441	-0,142	0,421			0,087	0,518
CMI	0,115	1,185	-0,239	2,180	-0,843	0,997	0,004	0,362	-0,229	0,338	-0,087	0,518		
LNE	0,378	1,203	0,024	2,189	-0,580	1,018	0,267	0,416	0,034	0,396	0,176	0,557	0,263	0,497
INM	0,258	1,492	-0,096	2,361	-0,700	1,347	0,147	0,976	-0,086	0,967	0,056	1,044	0,143	1,013
INRIM	0,246	1,162	-0,108	2,167	-0,712	0,969	0,136	0,276	-0,098	0,243	0,044	0,462	0,131	0,387
NPL	0,338	1,147	-0,016	2,159	-0,620	0,951	0,227	0,203	-0,006	0,156	0,136	0,423	0,223	0,339
NRC	0,170	1,163	-0,183	2,168	-0,787	0,971	0,060	0,282	-0,173	0,250	-0,031	0,465	0,056	0,391
NMIA	0,398	1,217	0,044	2,197	-0,560	1,034	0,287	0,455	0,054	0,436	0,196	0,587	0,283	0,530
VNIIM	13,458	1,919	13,104	2,651	12,500	1,809	13,347	1,552	13,114	1,547	13,256	1,596	13,343	1,576
MIKES	0,363	1,152	0,010	2,162	-0,594	0,957	0,253	0,229	0,020	0,189	0,162	0,436	0,249	0,355
VSL	0,253	1,161	-0,100	2,167	-0,704	0,968	0,143	0,272	-0,090	0,238	0,052	0,459	0,139	0,384
GUM	0,558	1,403	0,204	2,306	-0,400	1,248	0,447	0,834	0,214	0,824	0,356	0,913	0,443	0,877
INMETRO	0,208	1,184	-0,146	2,179	-0,750	0,995	0,097	0,358	-0,136	0,333	0,006	0,515	0,093	0,449
CENAM	-0,330	1,186	-0,684	2,180	-1,288	0,997	-0,441	0,363	-0,674	0,339	-0,532	0,519	-0,445	0,454
CEM4	0,353	1,146	0,000	2,159	-0,604	0,950	0,243	0,200	0,010	0,152	0,152	0,421	0,239	0,338

Gauge 4	LNE		INM		INRIM		NPL		NRC		NMIA		VNIIM	
140 mm	$D_{ij} / \mu\text{m}$	$U_{ij} / \mu\text{m}$	$D_{ij} / \mu\text{m}$	$U_{ij} / \mu\text{m}$	$D_{ij} / \mu\text{m}$	$U_{ij} / \mu\text{m}$	$D_{ij} / \mu\text{m}$	$U_{ij} / \mu\text{m}$	$D_{ij} / \mu\text{m}$	$U_{ij} / \mu\text{m}$	$D_{ij} / \mu\text{m}$	$U_{ij} / \mu\text{m}$	$D_{ij} / \mu\text{m}$	$U_{ij} / \mu\text{m}$
BEV	-0,378	1,203	-0,258	1,492	-0,246	1,162	-0,338	1,147	-0,170	1,163	-0,398	1,217	-13,458	1,919
NML	-0,024	2,189	0,096	2,361	0,108	2,167	0,016	2,159	0,183	2,168	-0,044	2,197	-13,104	2,651
OMH	0,580	1,018	0,700	1,347	0,712	0,969	0,620	0,951	0,787	0,971	0,560	1,034	-12,500	1,809
SP	-0,267	0,416	-0,147	0,976	-0,136	0,276	-0,227	0,203	-0,060	0,282	-0,287	0,455	-13,347	1,552
CEM2	-0,034	0,396	0,086	0,967	0,098	0,243	0,006	0,156	0,173	0,250	-0,054	0,436	-13,114	1,547
CGM	-0,176	0,557	-0,056	1,044	-0,044	0,462	-0,136	0,423	0,031	0,465	-0,196	0,587	-13,256	1,596
CMI	-0,263	0,497	-0,143	1,013	-0,131	0,387	-0,223	0,339	-0,056	0,391	-0,283	0,530	-13,343	1,576
LNE			0,120	1,034	0,132	0,439	0,040	0,397	0,207	0,442	-0,020	0,569	-13,080	1,589
INM	-0,120	1,034			0,012	0,986	-0,080	0,968	0,087	0,987	-0,140	1,050	-13,200	1,818
INRIM	-0,132	0,439	-0,012	0,986			-0,092	0,246	0,076	0,314	-0,152	0,476	-13,212	1,558
NPL	-0,040	0,397	0,080	0,968	0,092	0,246			0,167	0,252	-0,060	0,438	-13,120	1,547
NRC	-0,207	0,442	-0,087	0,987	-0,076	0,314	-0,167	0,252			-0,227	0,479	-13,287	1,559
NMIA	0,020	0,569	0,140	1,050	0,152	0,476	0,060	0,438	0,227	0,479			-13,060	1,600
VNIIM	13,080	1,589	13,200	1,818	13,212	1,558	13,120	1,547	13,287	1,559	13,060	1,600		
MIKES	-0,014	0,411	0,106	0,974	0,118	0,268	0,026	0,192	0,193	0,273	-0,034	0,450	-13,094	1,551
VSL	-0,124	0,436	-0,004	0,984	0,007	0,305	-0,084	0,241	0,083	0,310	-0,144	0,473	-13,204	1,558
GUM	0,180	0,901	0,300	1,261	0,312	0,845	0,220	0,824	0,387	0,847	0,160	0,920	-12,900	1,746
INMETRO	-0,170	0,494	-0,050	1,012	-0,038	0,384	-0,130	0,335	0,037	0,388	-0,190	0,528	-13,250	1,575
CENAM	-0,708	0,498	-0,588	1,014	-0,576	0,389	-0,668	0,341	-0,501	0,393	-0,728	0,531	-13,788	1,576
CEM4	-0,024	0,396	0,096	0,967	0,108	0,243	0,016	0,156	0,183	0,250	-0,044	0,436	-13,104	1,547

Gauge 4	MIKES		VSL		GUM		INMETRO		CENAM		CEM4	
140 mm	$D_{ij} / \mu\text{m}$	$U_{ij} / \mu\text{m}$	$D_{ij} / \mu\text{m}$	$U_{ij} / \mu\text{m}$	$D_{ij} / \mu\text{m}$	$U_{ij} / \mu\text{m}$	$D_{ij} / \mu\text{m}$	$U_{ij} / \mu\text{m}$	$D_{ij} / \mu\text{m}$	$U_{ij} / \mu\text{m}$	$D_{ij} / \mu\text{m}$	$U_{ij} / \mu\text{m}$
BEV	-0,363	1,152	-0,253	1,161	-0,558	1,403	-0,208	1,184	0,330	1,186	-0,353	1,146
NML	-0,010	2,162	0,100	2,167	-0,204	2,306	0,146	2,179	0,684	2,180	0,000	2,159
OMH	0,594	0,957	0,704	0,968	0,400	1,248	0,750	0,995	1,288	0,997	0,604	0,950
SP	-0,253	0,229	-0,143	0,272	-0,447	0,834	-0,097	0,358	0,441	0,363	-0,243	0,200
CEM2	-0,020	0,189	0,090	0,238	-0,214	0,824	0,136	0,333	0,674	0,339	-0,010	0,152
CGM	-0,162	0,436	-0,052	0,459	-0,356	0,913	-0,006	0,515	0,532	0,519	-0,152	0,421
CMI	-0,249	0,355	-0,139	0,384	-0,443	0,877	-0,093	0,449	0,445	0,454	-0,239	0,338
LNE	0,014	0,411	0,124	0,436	-0,180	0,901	0,170	0,494	0,708	0,498	0,024	0,396
INM	-0,106	0,974	0,004	0,984	-0,300	1,261	0,050	1,012	0,588	1,014	-0,096	0,967
INRIM	-0,118	0,268	-0,007	0,305	-0,312	0,845	0,038	0,384	0,576	0,389	-0,108	0,243
NPL	-0,026	0,192	0,084	0,241	-0,220	0,824	0,130	0,335	0,668	0,341	-0,016	0,156
NRC	-0,193	0,273	-0,083	0,310	-0,387	0,847	-0,037	0,388	0,501	0,393	-0,183	0,250
NMIA	0,034	0,450	0,144	0,473	-0,160	0,920	0,190	0,528	0,728	0,531	0,044	0,436
VNIIM	13,094	1,551	13,204	1,558	12,900	1,746	13,250	1,575	13,788	1,576	13,104	1,547
MIKES			0,110	0,263	-0,194	0,831	0,156	0,352	0,694	0,357	0,010	0,189
VSL	-0,110	0,263			-0,304	0,844	0,046	0,381	0,584	0,385	-0,100	0,238
GUM	0,194	0,831	0,304	0,844			0,350	0,876	0,888	0,878	0,204	0,824
INMETRO	-0,156	0,352	-0,046	0,381	-0,350	0,876			0,538	0,450	-0,146	0,333
CENAM	-0,694	0,357	-0,584	0,385	-0,888	0,878	-0,538	0,450			-0,684	0,339
CEM4	-0,010	0,189	0,100	0,238	-0,204	0,824	0,146	0,333	0,684	0,339		

Gauge 6	BEV		NML		OMH		SP		CEM2		CGM		CMI	
200 mm	$D_{ij} / \mu\text{m}$	$U_{ij} / \mu\text{m}$	$D_{ij} / \mu\text{m}$	$U_{ij} / \mu\text{m}$	$D_{ij} / \mu\text{m}$	$U_{ij} / \mu\text{m}$	$D_{ij} / \mu\text{m}$	$U_{ij} / \mu\text{m}$	$D_{ij} / \mu\text{m}$	$U_{ij} / \mu\text{m}$	$D_{ij} / \mu\text{m}$	$U_{ij} / \mu\text{m}$	$D_{ij} / \mu\text{m}$	$U_{ij} / \mu\text{m}$
BEV			0,497	2,410	-0,103	1,485	0,071	1,093	-0,002	1,084	0,110	1,157	0,009	1,131
NML	-0,497	2,410			-0,600	2,386	-0,426	2,164	-0,499	2,160	-0,387	2,197	-0,488	2,183
OMH	0,103	1,485	0,600	2,386			0,174	1,039	0,101	1,030	0,213	1,106	0,112	1,079
SP	-0,071	1,093	0,426	2,164	-0,174	1,039			-0,073	0,222	0,039	0,461	-0,063	0,391
CEM2	0,002	1,084	0,499	2,160	-0,101	1,030	0,073	0,222			0,112	0,440	0,011	0,367
CGM	-0,110	1,157	0,387	2,197	-0,213	1,106	-0,039	0,461	-0,112	0,440			-0,102	0,545
CMI	-0,009	1,131	0,488	2,183	-0,112	1,079	0,063	0,391	-0,011	0,367	0,102	0,545		
LNE	0,283	1,160	0,780	2,199	0,180	1,109	0,354	0,469	0,281	0,448	0,393	0,603	0,292	0,552
INM	0,683	1,471	1,180	2,377	0,580	1,431	0,754	1,018	0,681	1,009	0,793	1,087	0,692	1,059
INRIM	0,071	1,103	0,568	2,169	-0,032	1,050	0,143	0,302	0,069	0,270	0,181	0,485	0,080	0,420
NPL	0,173	1,085	0,670	2,160	0,070	1,030	0,244	0,224	0,171	0,178	0,283	0,441	0,182	0,368
NRC	0,093	1,102	0,590	2,169	-0,010	1,049	0,164	0,299	0,091	0,266	0,203	0,483	0,102	0,417
NMIA	0,203	1,175	0,700	2,207	0,100	1,125	0,274	0,505	0,201	0,486	0,313	0,632	0,212	0,583
VNIIM	7,303	1,910	7,800	2,671	7,200	1,880	7,374	1,588	7,301	1,582	7,413	1,633	7,312	1,615
MIKES	0,122	1,089	0,618	2,162	0,018	1,034	0,193	0,243	0,119	0,202	0,232	0,451	0,130	0,380
VSL	-0,024	1,109	0,473	2,172	-0,127	1,056	0,047	0,322	-0,026	0,292	0,086	0,498	-0,015	0,434
GUM	0,803	1,360	1,300	2,310	0,700	1,317	0,874	0,850	0,801	0,839	0,913	0,931	0,812	0,899
INMETRO	0,613	1,127	1,110	2,182	0,510	1,075	0,684	0,381	0,611	0,356	0,723	0,538	0,622	0,480
CENAM	-0,516	1,126	-0,019	2,181	-0,619	1,074	-0,444	0,377	-0,518	0,352	-0,405	0,535	-0,507	0,477
CEM4	-0,605	1,084	-0,108	2,160	-0,708	1,030	-0,534	0,222	-0,607	0,176	-0,495	0,440	-0,596	0,367

Gauge 6	LNE		INM		INRIM		NPL		NRC		NMIA		VNIIM	
200 mm	$D_{ij} / \mu\text{m}$	$U_{ij} / \mu\text{m}$	$D_{ij} / \mu\text{m}$	$U_{ij} / \mu\text{m}$	$D_{ij} / \mu\text{m}$	$U_{ij} / \mu\text{m}$	$D_{ij} / \mu\text{m}$	$U_{ij} / \mu\text{m}$	$D_{ij} / \mu\text{m}$	$U_{ij} / \mu\text{m}$	$D_{ij} / \mu\text{m}$	$U_{ij} / \mu\text{m}$	$D_{ij} / \mu\text{m}$	$U_{ij} / \mu\text{m}$
BEV	-0,283	1,160	-0,683	1,471	-0,071	1,103	-0,173	1,085	-0,093	1,102	-0,203	1,175	-7,303	1,910
NML	-0,780	2,199	-1,180	2,377	-0,568	2,169	-0,670	2,160	-0,590	2,169	-0,700	2,207	-7,800	2,671
OMH	-0,180	1,109	-0,580	1,431	0,032	1,050	-0,070	1,030	0,010	1,049	-0,100	1,125	-7,200	1,880
SP	-0,354	0,469	-0,754	1,018	-0,143	0,302	-0,244	0,224	-0,164	0,299	-0,274	0,505	-7,374	1,588
CEM2	-0,281	0,448	-0,681	1,009	-0,069	0,270	-0,171	0,178	-0,091	0,266	-0,201	0,486	-7,301	1,582
CGM	-0,393	0,603	-0,793	1,087	-0,181	0,485	-0,283	0,441	-0,203	0,483	-0,313	0,632	-7,413	1,633
CMI	-0,292	0,552	-0,692	1,059	-0,080	0,420	-0,182	0,368	-0,102	0,417	-0,212	0,583	-7,312	1,615
LNE			-0,400	1,090	0,212	0,493	0,110	0,449	0,190	0,491	0,080	0,637	-7,020	1,635
INM	0,400	1,090			0,612	1,029	0,510	1,009	0,590	1,028	0,480	1,106	-6,620	1,868
INRIM	-0,212	0,493	-0,612	1,029			-0,102	0,271	-0,022	0,336	-0,132	0,527	-7,232	1,595
NPL	-0,110	0,449	-0,510	1,009	0,102	0,271			0,080	0,267	-0,030	0,487	-7,130	1,583
NRC	-0,190	0,491	-0,590	1,028	0,022	0,336	-0,080	0,267			-0,110	0,525	-7,210	1,595
NMIA	-0,080	0,637	-0,480	1,106	0,132	0,527	0,030	0,487	0,110	0,525			-7,100	1,646
VNIIM	7,020	1,635	6,620	1,868	7,232	1,595	7,130	1,583	7,210	1,595	7,100	1,646		
MIKES	-0,162	0,459	-0,562	1,014	0,050	0,287	-0,052	0,203	0,028	0,284	-0,082	0,496	-7,182	1,585
VSL	-0,307	0,505	-0,707	1,035	-0,095	0,356	-0,197	0,293	-0,117	0,354	-0,227	0,539	-7,327	1,599
GUM	0,520	0,935	0,120	1,301	0,732	0,864	0,630	0,840	0,710	0,863	0,600	0,954	-6,500	1,782
INMETRO	0,330	0,545	-0,070	1,055	0,542	0,410	0,440	0,357	0,520	0,408	0,410	0,576	-6,690	1,612
CENAM	-0,799	0,542	-1,199	1,054	-0,587	0,407	-0,689	0,353	-0,609	0,405	-0,719	0,574	-7,819	1,611
CEM4	-0,888	0,448	-1,288	1,009	-0,676	0,270	-0,778	0,178	-0,698	0,266	-0,808	0,486	-7,908	1,582

Gauge 6	MIKES		VSL		GUM		INMETRO		CENAM		CEM4	
200 mm	$D_{ij} / \mu\text{m}$	$U_{ij} / \mu\text{m}$	$D_{ij} / \mu\text{m}$	$U_{ij} / \mu\text{m}$	$D_{ij} / \mu\text{m}$	$U_{ij} / \mu\text{m}$	$D_{ij} / \mu\text{m}$	$U_{ij} / \mu\text{m}$	$D_{ij} / \mu\text{m}$	$U_{ij} / \mu\text{m}$	$D_{ij} / \mu\text{m}$	$U_{ij} / \mu\text{m}$
BEV	-0,122	1,089	0,024	1,109	-0,803	1,360	-0,613	1,127	0,516	1,126	0,605	1,084
NML	-0,618	2,162	-0,473	2,172	-1,300	2,310	-1,110	2,182	0,019	2,181	0,108	2,160
OMH	-0,018	1,034	0,127	1,056	-0,700	1,317	-0,510	1,075	0,619	1,074	0,708	1,030
SP	-0,193	0,243	-0,047	0,322	-0,874	0,850	-0,684	0,381	0,444	0,377	0,534	0,222
CEM2	-0,119	0,202	0,026	0,292	-0,801	0,839	-0,611	0,356	0,518	0,352	0,607	0,176
CGM	-0,232	0,451	-0,086	0,498	-0,913	0,931	-0,723	0,538	0,405	0,535	0,495	0,440
CMI	-0,130	0,380	0,015	0,434	-0,812	0,899	-0,622	0,480	0,507	0,477	0,596	0,367
LNE	0,162	0,459	0,307	0,505	-0,520	0,935	-0,330	0,545	0,799	0,542	0,888	0,448
INM	0,562	1,014	0,707	1,035	-0,120	1,301	0,070	1,055	1,199	1,054	1,288	1,009
INRIM	-0,050	0,287	0,095	0,356	-0,732	0,864	-0,542	0,410	0,587	0,407	0,676	0,270
NPL	0,052	0,203	0,197	0,293	-0,630	0,840	-0,440	0,357	0,689	0,353	0,778	0,178
NRC	-0,028	0,284	0,117	0,354	-0,710	0,863	-0,520	0,408	0,609	0,405	0,698	0,266
NMIA	0,082	0,496	0,227	0,539	-0,600	0,954	-0,410	0,576	0,719	0,574	0,808	0,486
VNIIM	7,182	1,585	7,327	1,599	6,500	1,782	6,690	1,612	7,819	1,611	7,908	1,582
MIKES			0,145	0,308	-0,682	0,845	-0,492	0,369	0,637	0,366	0,726	0,202
VSL	-0,145	0,308			-0,827	0,871	-0,637	0,425	0,492	0,422	0,581	0,292
GUM	0,682	0,845	0,827	0,871			0,190	0,894	1,319	0,893	1,408	0,839
INMETRO	0,492	0,369	0,637	0,425	-0,190	0,894			1,129	0,468	1,218	0,356
CENAM	-0,637	0,366	-0,492	0,422	-1,319	0,893	-1,129	0,468			0,089	0,352
CEM4	-0,726	0,202	-0,581	0,292	-1,408	0,839	-1,218	0,356	-0,089	0,352		

Gauge 6	BEV		NML		OMH		SP		CEM2		CGM		CMI	
220 mm	$D_{ij} / \mu\text{m}$	$U_{ij} / \mu\text{m}$	$D_{ij} / \mu\text{m}$	$U_{ij} / \mu\text{m}$	$D_{ij} / \mu\text{m}$	$U_{ij} / \mu\text{m}$	$D_{ij} / \mu\text{m}$	$U_{ij} / \mu\text{m}$	$D_{ij} / \mu\text{m}$	$U_{ij} / \mu\text{m}$	$D_{ij} / \mu\text{m}$	$U_{ij} / \mu\text{m}$	$D_{ij} / \mu\text{m}$	$U_{ij} / \mu\text{m}$
BEV			-0,760	2,469	-0,765	1,598	-0,506	1,217	-0,658	1,210	-0,514	1,277	-0,504	1,254
NML	0,760	2,469			-0,005	2,399	0,254	2,164	0,102	2,160	0,246	2,198	0,256	2,185
OMH	0,765	1,598	0,005	2,399			0,259	1,070	0,107	1,061	0,251	1,136	0,261	1,111
SP	0,506	1,217	-0,254	2,164	-0,259	1,070			-0,152	0,230	-0,008	0,468	0,002	0,402
CEM2	0,658	1,210	-0,102	2,160	-0,107	1,061	0,152	0,230			0,144	0,448	0,154	0,378
CGM	0,514	1,277	-0,246	2,198	-0,251	1,136	0,008	0,468	-0,144	0,448			0,010	0,556
CMI	0,504	1,254	-0,256	2,185	-0,261	1,111	-0,002	0,402	-0,154	0,378	-0,010	0,556		
LNE	0,805	1,284	0,045	2,202	0,040	1,145	0,299	0,488	0,147	0,468	0,291	0,621	0,301	0,573
INM	0,645	1,575	-0,115	2,384	-0,120	1,464	0,139	1,035	-0,013	1,026	0,131	1,104	0,141	1,077
INRIM	0,704	1,228	-0,056	2,170	-0,061	1,081	0,198	0,312	0,047	0,280	0,190	0,495	0,200	0,432
NPL	0,765	1,210	0,005	2,160	0,000	1,061	0,259	0,231	0,107	0,186	0,251	0,448	0,261	0,379
NRC	0,650	1,226	-0,110	2,169	-0,115	1,080	0,144	0,305	-0,007	0,273	0,137	0,491	0,147	0,428
NMIA	0,915	1,298	0,155	2,210	0,150	1,160	0,409	0,523	0,257	0,505	0,401	0,649	0,411	0,603
VNIIM	8,165	1,995	7,405	2,680	7,400	1,908	7,659	1,603	7,507	1,597	7,651	1,648	7,661	1,630
MIKES	0,726	1,213	-0,034	2,162	-0,039	1,065	0,220	0,248	0,068	0,207	0,212	0,457	0,222	0,389
VSL	0,529	1,235	-0,231	2,175	-0,236	1,090	0,023	0,340	-0,128	0,312	0,016	0,513	0,026	0,454
GUM	1,365	1,464	0,605	2,312	0,600	1,344	0,859	0,857	0,707	0,846	0,851	0,939	0,861	0,908
INMETRO	1,155	1,250	0,395	2,183	0,390	1,107	0,649	0,390	0,497	0,365	0,641	0,547	0,651	0,492
CENAM	0,024	1,248	-0,736	2,182	-0,741	1,104	-0,482	0,383	-0,633	0,358	-0,490	0,543	-0,480	0,487
CEM4	0,073	1,210	-0,687	2,160	-0,692	1,061	-0,433	0,230	-0,584	0,185	-0,440	0,448	-0,431	0,378

Gauge 6	LNE		INM		INRIM		NPL		NRC		NMIA		VNIIM	
220 mm	$D_{ij} / \mu\text{m}$	$U_{ij} / \mu\text{m}$	$D_{ij} / \mu\text{m}$	$U_{ij} / \mu\text{m}$	$D_{ij} / \mu\text{m}$	$U_{ij} / \mu\text{m}$	$D_{ij} / \mu\text{m}$	$U_{ij} / \mu\text{m}$	$D_{ij} / \mu\text{m}$	$U_{ij} / \mu\text{m}$	$D_{ij} / \mu\text{m}$	$U_{ij} / \mu\text{m}$	$D_{ij} / \mu\text{m}$	$U_{ij} / \mu\text{m}$
BEV	-0,805	1,284	-0,645	1,575	-0,704	1,228	-0,765	1,210	-0,650	1,226	-0,915	1,298	-8,165	1,995
NML	-0,045	2,202	0,115	2,384	0,056	2,170	-0,005	2,160	0,110	2,169	-0,155	2,210	-7,405	2,680
OMH	-0,040	1,145	0,120	1,464	0,061	1,081	0,000	1,061	0,115	1,080	-0,150	1,160	-7,400	1,908
SP	-0,299	0,488	-0,139	1,035	-0,198	0,312	-0,259	0,231	-0,144	0,305	-0,409	0,523	-7,659	1,603
CEM2	-0,147	0,468	0,013	1,026	-0,047	0,280	-0,107	0,186	0,007	0,273	-0,257	0,505	-7,507	1,597
CGM	-0,291	0,621	-0,131	1,104	-0,190	0,495	-0,251	0,448	-0,137	0,491	-0,401	0,649	-7,651	1,648
CMI	-0,301	0,573	-0,141	1,077	-0,200	0,432	-0,261	0,379	-0,147	0,428	-0,411	0,603	-7,661	1,630
LNE			0,160	1,112	0,101	0,513	0,040	0,469	0,155	0,509	-0,110	0,663	-7,360	1,654
INM	-0,160	1,112			-0,059	1,047	-0,120	1,026	-0,005	1,045	-0,270	1,128	-7,520	1,889
INRIM	-0,101	0,513	0,059	1,047			-0,061	0,281	0,054	0,344	-0,211	0,547	-7,461	1,610
NPL	-0,040	0,469	0,120	1,026	0,061	0,281			0,115	0,273	-0,150	0,505	-7,400	1,597
NRC	-0,155	0,509	0,005	1,045	-0,054	0,344	-0,115	0,273			-0,265	0,543	-7,515	1,609
NMIA	0,110	0,663	0,270	1,128	0,211	0,547	0,150	0,505	0,265	0,543			-7,250	1,664
VNIIM	7,360	1,654	7,520	1,889	7,461	1,610	7,400	1,597	7,515	1,609	7,250	1,664		
MIKES	-0,079	0,478	0,081	1,030	0,022	0,295	-0,039	0,208	0,076	0,288	-0,189	0,513	-7,439	1,599
VSL	-0,276	0,531	-0,116	1,056	-0,175	0,376	-0,236	0,312	-0,121	0,370	-0,386	0,564	-7,636	1,616
GUM	0,560	0,949	0,720	1,316	0,661	0,871	0,600	0,846	0,715	0,869	0,450	0,967	-6,800	1,797
INMETRO	0,350	0,564	0,510	1,073	0,451	0,421	0,390	0,366	0,505	0,417	0,240	0,595	-7,010	1,627
CENAM	-0,781	0,560	-0,621	1,070	-0,680	0,415	-0,741	0,359	-0,626	0,410	-0,891	0,591	-8,141	1,626
CEM4	-0,732	0,468	-0,572	1,026	-0,631	0,280	-0,692	0,186	-0,577	0,273	-0,842	0,505	-8,092	1,597

Gauge 6	MIKES		VSL		GUM		INMETRO		CENAM		CEM4	
220 mm	$D_{ij} / \mu\text{m}$	$U_{ij} / \mu\text{m}$	$D_{ij} / \mu\text{m}$	$U_{ij} / \mu\text{m}$	$D_{ij} / \mu\text{m}$	$U_{ij} / \mu\text{m}$	$D_{ij} / \mu\text{m}$	$U_{ij} / \mu\text{m}$	$D_{ij} / \mu\text{m}$	$U_{ij} / \mu\text{m}$	$D_{ij} / \mu\text{m}$	$U_{ij} / \mu\text{m}$
BEV	-0,726	1,213	-0,529	1,235	-1,365	1,464	-1,155	1,250	-0,024	1,248	-0,073	1,210
NML	0,034	2,162	0,231	2,175	-0,605	2,312	-0,395	2,183	0,736	2,182	0,687	2,160
OMH	0,039	1,065	0,236	1,090	-0,600	1,344	-0,390	1,107	0,741	1,104	0,692	1,061
SP	-0,220	0,248	-0,023	0,340	-0,859	0,857	-0,649	0,390	0,482	0,383	0,433	0,230
CEM2	-0,068	0,207	0,128	0,312	-0,707	0,846	-0,497	0,365	0,633	0,358	0,584	0,185
CGM	-0,212	0,457	-0,016	0,513	-0,851	0,939	-0,641	0,547	0,490	0,543	0,440	0,448
CMI	-0,222	0,389	-0,026	0,454	-0,861	0,908	-0,651	0,492	0,480	0,487	0,431	0,378
LNE	0,079	0,478	0,276	0,531	-0,560	0,949	-0,350	0,564	0,781	0,560	0,732	0,468
INM	-0,081	1,030	0,116	1,056	-0,720	1,316	-0,510	1,073	0,621	1,070	0,572	1,026
INRIM	-0,022	0,295	0,175	0,376	-0,661	0,871	-0,451	0,421	0,680	0,415	0,631	0,280
NPL	0,039	0,208	0,236	0,312	-0,600	0,846	-0,390	0,366	0,741	0,359	0,692	0,186
NRC	-0,076	0,288	0,121	0,370	-0,715	0,869	-0,505	0,417	0,626	0,410	0,577	0,273
NMIA	0,189	0,513	0,386	0,564	-0,450	0,967	-0,240	0,595	0,891	0,591	0,842	0,505
VNIIM	7,439	1,599	7,636	1,616	6,800	1,797	7,010	1,627	8,141	1,626	8,092	1,597
MIKES			0,197	0,325	-0,639	0,851	-0,429	0,377	0,702	0,370	0,653	0,207
VSL	-0,197	0,325			-0,836	0,882	-0,626	0,443	0,505	0,437	0,456	0,312
GUM	0,639	0,851	0,836	0,882			0,210	0,902	1,341	0,899	1,292	0,846
INMETRO	0,429	0,377	0,626	0,443	-0,210	0,902			1,131	0,477	1,082	0,365
CENAM	-0,702	0,370	-0,505	0,437	-1,341	0,899	-1,131	0,477			-0,049	0,358
CEM4	-0,653	0,207	-0,456	0,312	-1,292	0,846	-1,082	0,365	0,049	0,358		

Gauge 9	BEV		NML		OMH		SP		CEM2		CGM		CMI	
320 mm	$D_{ij} / \mu\text{m}$	$U_{ij} / \mu\text{m}$	$D_{ij} / \mu\text{m}$	$U_{ij} / \mu\text{m}$	$D_{ij} / \mu\text{m}$	$U_{ij} / \mu\text{m}$	$D_{ij} / \mu\text{m}$	$U_{ij} / \mu\text{m}$	$D_{ij} / \mu\text{m}$	$U_{ij} / \mu\text{m}$	$D_{ij} / \mu\text{m}$	$U_{ij} / \mu\text{m}$	$D_{ij} / \mu\text{m}$	$U_{ij} / \mu\text{m}$
BEV			0,344	2,646	-0,198	1,728	-0,102	1,232	-0,091	1,224	0,086	1,299	-0,114	1,281
NML	-0,344	2,646			-0,542	2,655	-0,447	2,362	-0,435	2,358	-0,258	2,398	-0,458	2,388
OMH	0,198	1,728	0,542	2,655			0,095	1,249	0,107	1,242	0,283	1,316	0,084	1,298
SP	0,102	1,232	0,447	2,362	-0,095	1,249			0,012	0,272	0,188	0,513	-0,011	0,465
CEM2	0,091	1,224	0,435	2,358	-0,107	1,242	-0,012	0,272			0,177	0,494	-0,023	0,444
CGM	-0,086	1,299	0,258	2,398	-0,283	1,316	-0,188	0,513	-0,177	0,494			-0,200	0,622
CMI	0,114	1,281	0,458	2,388	-0,084	1,298	0,011	0,465	0,023	0,444	0,200	0,622		
LNE	0,308	1,335	0,652	2,417	0,110	1,351	0,205	0,597	0,217	0,581	0,393	0,726	0,194	0,693
INM	0,198	1,647	0,542	2,603	0,000	1,660	0,095	1,135	0,107	1,127	0,283	1,208	0,084	1,188
INRIM	-0,183	1,248	0,161	2,370	-0,381	1,265	-0,286	0,364	-0,274	0,338	-0,098	0,551	-0,297	0,506
NPL	-0,072	1,224	0,272	2,358	-0,270	1,241	-0,175	0,269	-0,163	0,233	0,013	0,493	-0,186	0,443
NRC	-0,130	1,241	0,214	2,367	-0,328	1,259	-0,233	0,340	-0,221	0,311	-0,044	0,535	-0,244	0,489
NMIA	0,128	1,349	0,472	2,425	-0,070	1,365	0,025	0,628	0,037	0,613	0,213	0,752	0,014	0,720
VNIIM	-0,302	2,071	0,042	2,889	-0,500	2,081	-0,405	1,692	-0,393	1,686	-0,217	1,742	-0,416	1,728
MIKES	-0,141	1,225	0,203	2,358	-0,338	1,243	-0,243	0,274	-0,232	0,238	-0,055	0,496	-0,255	0,446
VSL	-0,302	1,272	0,042	2,383	-0,500	1,288	-0,405	0,437	-0,393	0,416	-0,217	0,601	-0,416	0,561
GUM	0,898	1,493	1,242	2,508	0,700	1,507	0,795	0,896	0,807	0,885	0,983	0,986	0,784	0,962
INMETRO	0,418	1,274	0,762	2,384	0,220	1,291	0,315	0,444	0,327	0,422	0,503	0,606	0,304	0,566
CENAM	-0,870	1,263	-0,526	2,378	-1,067	1,280	-0,972	0,411	-0,961	0,388	-0,784	0,583	-0,984	0,541
CEM4	-0,894	1,224	-0,550	2,358	-1,092	1,242	-0,997	0,272	-0,985	0,235	-0,809	0,494	-1,008	0,444

Gauge 9	LNE		INM		INRIM		NPL		NRC		NMIA		VNIIM	
320 mm	$D_{ij} / \mu\text{m}$	$U_{ij} / \mu\text{m}$	$D_{ij} / \mu\text{m}$	$U_{ij} / \mu\text{m}$	$D_{ij} / \mu\text{m}$	$U_{ij} / \mu\text{m}$	$D_{ij} / \mu\text{m}$	$U_{ij} / \mu\text{m}$	$D_{ij} / \mu\text{m}$	$U_{ij} / \mu\text{m}$	$D_{ij} / \mu\text{m}$	$U_{ij} / \mu\text{m}$	$D_{ij} / \mu\text{m}$	$U_{ij} / \mu\text{m}$
BEV	-0,308	1,335	-0,198	1,647	0,183	1,248	0,072	1,224	0,130	1,241	-0,128	1,349	0,302	2,071
NML	-0,652	2,417	-0,542	2,603	-0,161	2,370	-0,272	2,358	-0,214	2,367	-0,472	2,425	-0,042	2,889
OMH	-0,110	1,351	0,000	1,660	0,381	1,265	0,270	1,241	0,328	1,259	0,070	1,365	0,500	2,081
SP	-0,205	0,597	-0,095	1,135	0,286	0,364	0,175	0,269	0,233	0,340	-0,025	0,628	0,405	1,692
CEM2	-0,217	0,581	-0,107	1,127	0,274	0,338	0,163	0,233	0,221	0,311	-0,037	0,613	0,393	1,686
CGM	-0,393	0,726	-0,283	1,208	0,098	0,551	-0,013	0,493	0,044	0,535	-0,213	0,752	0,217	1,742
CMI	-0,194	0,693	-0,084	1,188	0,297	0,506	0,186	0,443	0,244	0,489	-0,014	0,720	0,416	1,728
LNE			0,110	1,246	0,491	0,630	0,380	0,580	0,438	0,616	0,180	0,811	0,610	1,768
INM	-0,110	1,246			0,381	1,153	0,270	1,126	0,328	1,145	0,070	1,261	0,500	2,015
INRIM	-0,491	0,630	-0,381	1,153			-0,111	0,336	-0,053	0,395	-0,311	0,659	0,119	1,704
NPL	-0,380	0,580	-0,270	1,126	0,111	0,336			0,058	0,309	-0,200	0,612	0,230	1,686
NRC	-0,438	0,616	-0,328	1,145	0,053	0,395	-0,058	0,309			-0,258	0,646	0,172	1,699
NMIA	-0,180	0,811	-0,070	1,261	0,311	0,659	0,200	0,612	0,258	0,646			0,430	1,779
VNIIM	-0,610	1,768	-0,500	2,015	-0,119	1,704	-0,230	1,686	-0,172	1,699	-0,430	1,779		
MIKES	-0,448	0,582	-0,338	1,127	0,043	0,340	-0,068	0,236	-0,011	0,313	-0,268	0,614	0,162	1,687
VSL	-0,610	0,674	-0,500	1,178	-0,119	0,481	-0,230	0,414	-0,172	0,463	-0,430	0,702	0,000	1,721
GUM	0,590	1,033	0,700	1,414	1,081	0,918	0,970	0,885	1,028	0,909	0,770	1,051	1,200	1,890
INMETRO	0,110	0,679	0,220	1,180	0,601	0,487	0,490	0,421	0,548	0,469	0,290	0,706	0,720	1,723
CENAM	-1,177	0,658	-1,067	1,168	-0,686	0,458	-0,797	0,387	-0,740	0,438	-0,997	0,687	-0,567	1,715
CEM4	-1,202	0,581	-1,092	1,127	-0,711	0,338	-0,822	0,233	-0,764	0,311	-1,022	0,613	-0,592	1,686

Gauge 9	MIKES		VSL		GUM		INMETRO		CENAM		CEM4	
320 mm	$D_{ij} / \mu\text{m}$	$U_{ij} / \mu\text{m}$	$D_{ij} / \mu\text{m}$	$U_{ij} / \mu\text{m}$	$D_{ij} / \mu\text{m}$	$U_{ij} / \mu\text{m}$	$D_{ij} / \mu\text{m}$	$U_{ij} / \mu\text{m}$	$D_{ij} / \mu\text{m}$	$U_{ij} / \mu\text{m}$	$D_{ij} / \mu\text{m}$	$U_{ij} / \mu\text{m}$
BEV	0,141	1,225	0,302	1,272	-0,898	1,493	-0,418	1,274	0,870	1,263	0,894	1,224
NML	-0,203	2,358	-0,042	2,383	-1,242	2,508	-0,762	2,384	0,526	2,378	0,550	2,358
OMH	0,338	1,243	0,500	1,288	-0,700	1,507	-0,220	1,291	1,067	1,280	1,092	1,242
SP	0,243	0,274	0,405	0,437	-0,795	0,896	-0,315	0,444	0,972	0,411	0,997	0,272
CEM2	0,232	0,238	0,393	0,416	-0,807	0,885	-0,327	0,422	0,961	0,388	0,985	0,235
CGM	0,055	0,496	0,217	0,601	-0,983	0,986	-0,503	0,606	0,784	0,583	0,809	0,494
CMI	0,255	0,446	0,416	0,561	-0,784	0,962	-0,304	0,566	0,984	0,541	1,008	0,444
LNE	0,448	0,582	0,610	0,674	-0,590	1,033	-0,110	0,679	1,177	0,658	1,202	0,581
INM	0,338	1,127	0,500	1,178	-0,700	1,414	-0,220	1,180	1,067	1,168	1,092	1,127
INRIM	-0,043	0,340	0,119	0,481	-1,081	0,918	-0,601	0,487	0,686	0,458	0,711	0,338
NPL	0,068	0,236	0,230	0,414	-0,970	0,885	-0,490	0,421	0,797	0,387	0,822	0,233
NRC	0,011	0,313	0,172	0,463	-1,028	0,909	-0,548	0,469	0,740	0,438	0,764	0,311
NMIA	0,268	0,614	0,430	0,702	-0,770	1,051	-0,290	0,706	0,997	0,687	1,022	0,613
VNIIM	-0,162	1,687	0,000	1,721	-1,200	1,890	-0,720	1,723	0,567	1,715	0,592	1,686
MIKES			0,162	0,417	-1,038	0,886	-0,558	0,424	0,729	0,390	0,754	0,238
VSL	-0,162	0,417			-1,200	0,949	-0,720	0,544	0,567	0,518	0,592	0,416
GUM	1,038	0,886	1,200	0,949			0,480	0,952	1,767	0,938	1,792	0,885
INMETRO	0,558	0,424	0,720	0,544	-0,480	0,952			1,287	0,523	1,312	0,422
CENAM	-0,729	0,390	-0,567	0,518	-1,767	0,938	-1,287	0,523			0,025	0,388
CEM4	-0,754	0,238	-0,592	0,416	-1,792	0,885	-1,312	0,422	-0,025	0,388		

Gauge 9	BEV		NML		OMH		SP		CEM2		CGM		CMI	
340 mm	$D_{ij} / \mu\text{m}$	$U_{ij} / \mu\text{m}$	$D_{ij} / \mu\text{m}$	$U_{ij} / \mu\text{m}$	$D_{ij} / \mu\text{m}$	$U_{ij} / \mu\text{m}$	$D_{ij} / \mu\text{m}$	$U_{ij} / \mu\text{m}$	$D_{ij} / \mu\text{m}$	$U_{ij} / \mu\text{m}$	$D_{ij} / \mu\text{m}$	$U_{ij} / \mu\text{m}$	$D_{ij} / \mu\text{m}$	$U_{ij} / \mu\text{m}$
BEV			-0,862	2,704	-0,719	1,843	-0,553	1,353	-0,614	1,346	-0,411	1,417	-0,508	1,401
NML	0,862	2,704			0,143	2,673	0,309	2,362	0,248	2,358	0,451	2,399	0,354	2,390
OMH	0,719	1,843	-0,143	2,673			0,166	1,289	0,105	1,282	0,307	1,356	0,211	1,340
SP	0,553	1,353	-0,309	2,362	-0,166	1,289			-0,061	0,280	0,141	0,523	0,045	0,478
CEM2	0,614	1,346	-0,248	2,358	-0,105	1,282	0,061	0,280			0,203	0,505	0,106	0,459
CGM	0,411	1,417	-0,451	2,399	-0,307	1,356	-0,141	0,523	-0,203	0,505			-0,096	0,637
CMI	0,508	1,401	-0,354	2,390	-0,211	1,340	-0,045	0,478	-0,106	0,459	0,096	0,637		
LNE	0,569	1,455	-0,293	2,422	-0,150	1,397	0,016	0,620	-0,045	0,605	0,157	0,749	0,061	0,719
INM	-0,021	1,754	-0,883	2,612	-0,740	1,705	-0,574	1,158	-0,635	1,150	-0,433	1,232	-0,529	1,214
INRIM	0,341	1,369	-0,521	2,372	-0,378	1,307	-0,212	0,376	-0,273	0,351	-0,070	0,564	-0,167	0,523
NPL	0,429	1,346	-0,433	2,358	-0,290	1,282	-0,124	0,277	-0,185	0,243	0,017	0,503	-0,079	0,457
NRC	0,272	1,362	-0,590	2,367	-0,446	1,299	-0,281	0,347	-0,342	0,320	-0,139	0,545	-0,235	0,502
NMIA	0,669	1,469	-0,193	2,431	-0,050	1,411	0,116	0,651	0,055	0,637	0,257	0,775	0,161	0,745
VNIIM	1,719	2,161	0,857	2,901	1,000	2,121	1,166	1,713	1,105	1,708	1,307	1,764	1,211	1,751
MIKES	0,287	1,346	-0,575	2,358	-0,432	1,282	-0,266	0,280	-0,327	0,245	-0,124	0,505	-0,221	0,459
VSL	0,136	1,394	-0,726	2,386	-0,583	1,332	-0,417	0,458	-0,478	0,437	-0,276	0,621	-0,372	0,584
GUM	1,219	1,598	0,357	2,511	0,500	1,544	0,666	0,905	0,605	0,895	0,807	0,998	0,711	0,975
INMETRO	0,829	1,393	-0,033	2,385	0,110	1,331	0,276	0,455	0,215	0,434	0,417	0,619	0,321	0,582
CENAM	-0,429	1,382	-1,291	2,379	-1,148	1,320	-0,982	0,419	-1,043	0,397	-0,841	0,593	-0,937	0,555
CEM4	-0,337	1,346	-1,200	2,358	-1,056	1,282	-0,890	0,280	-0,952	0,246	-0,749	0,505	-0,845	0,459

Gauge 9	BEV		NML		OMH		SP		CEM2		CGM		CMI	
340 mm	$D_{ij} / \mu\text{m}$	$U_{ij} / \mu\text{m}$	$D_{ij} / \mu\text{m}$	$U_{ij} / \mu\text{m}$	$D_{ij} / \mu\text{m}$	$U_{ij} / \mu\text{m}$	$D_{ij} / \mu\text{m}$	$U_{ij} / \mu\text{m}$	$D_{ij} / \mu\text{m}$	$U_{ij} / \mu\text{m}$	$D_{ij} / \mu\text{m}$	$U_{ij} / \mu\text{m}$	$D_{ij} / \mu\text{m}$	$U_{ij} / \mu\text{m}$
BEV			-0,862	2,704	-0,719	1,843	-0,553	1,353	-0,614	1,346	-0,411	1,417	-0,508	1,401
NML	0,862	2,704			0,143	2,673	0,309	2,362	0,248	2,358	0,451	2,399	0,354	2,390
OMH	0,719	1,843	-0,143	2,673			0,166	1,289	0,105	1,282	0,307	1,356	0,211	1,340
SP	0,553	1,353	-0,309	2,362	-0,166	1,289			-0,061	0,280	0,141	0,523	0,045	0,478
CEM2	0,614	1,346	-0,248	2,358	-0,105	1,282	0,061	0,280			0,203	0,505	0,106	0,459
CGM	0,411	1,417	-0,451	2,399	-0,307	1,356	-0,141	0,523	-0,203	0,505			-0,096	0,637
CMI	0,508	1,401	-0,354	2,390	-0,211	1,340	-0,045	0,478	-0,106	0,459	0,096	0,637		
LNE	0,569	1,455	-0,293	2,422	-0,150	1,397	0,016	0,620	-0,045	0,605	0,157	0,749	0,061	0,719
INM	-0,021	1,754	-0,883	2,612	-0,740	1,705	-0,574	1,158	-0,635	1,150	-0,433	1,232	-0,529	1,214
INRIM	0,341	1,369	-0,521	2,372	-0,378	1,307	-0,212	0,376	-0,273	0,351	-0,070	0,564	-0,167	0,523
NPL	0,429	1,346	-0,433	2,358	-0,290	1,282	-0,124	0,277	-0,185	0,243	0,017	0,503	-0,079	0,457
NRC	0,272	1,362	-0,590	2,367	-0,446	1,299	-0,281	0,347	-0,342	0,320	-0,139	0,545	-0,235	0,502
NMIA	0,669	1,469	-0,193	2,431	-0,050	1,411	0,116	0,651	0,055	0,637	0,257	0,775	0,161	0,745
VNIIM	1,719	2,161	0,857	2,901	1,000	2,121	1,166	1,713	1,105	1,708	1,307	1,764	1,211	1,751
MIKES	0,287	1,346	-0,575	2,358	-0,432	1,282	-0,266	0,280	-0,327	0,245	-0,124	0,505	-0,221	0,459
VSL	0,136	1,394	-0,726	2,386	-0,583	1,332	-0,417	0,458	-0,478	0,437	-0,276	0,621	-0,372	0,584
GUM	1,219	1,598	0,357	2,511	0,500	1,544	0,666	0,905	0,605	0,895	0,807	0,998	0,711	0,975
INMETRO	0,829	1,393	-0,033	2,385	0,110	1,331	0,276	0,455	0,215	0,434	0,417	0,619	0,321	0,582
CENAM	-0,429	1,382	-1,291	2,379	-1,148	1,320	-0,982	0,419	-1,043	0,397	-0,841	0,593	-0,937	0,555
CEM4	-0,337	1,346	-1,200	2,358	-1,056	1,282	-0,890	0,280	-0,952	0,246	-0,749	0,505	-0,845	0,459

Gauge 9	MIKES		VSL		GUM		INMETRO		CENAM		CEM4	
340 mm	$D_{ij} / \mu\text{m}$	$U_{ij} / \mu\text{m}$	$D_{ij} / \mu\text{m}$	$U_{ij} / \mu\text{m}$	$D_{ij} / \mu\text{m}$	$U_{ij} / \mu\text{m}$	$D_{ij} / \mu\text{m}$	$U_{ij} / \mu\text{m}$	$D_{ij} / \mu\text{m}$	$U_{ij} / \mu\text{m}$	$D_{ij} / \mu\text{m}$	$U_{ij} / \mu\text{m}$
BEV	-0,287	1,346	-0,136	1,394	-1,219	1,598	-0,829	1,393	0,429	1,382	0,337	1,346
NML	0,575	2,358	0,726	2,386	-0,357	2,511	0,033	2,385	1,291	2,379	1,200	2,358
OMH	0,432	1,282	0,583	1,332	-0,500	1,544	-0,110	1,331	1,148	1,320	1,056	1,282
SP	0,266	0,280	0,417	0,458	-0,666	0,905	-0,276	0,455	0,982	0,419	0,890	0,280
CEM2	0,327	0,245	0,478	0,437	-0,605	0,895	-0,215	0,434	1,043	0,397	0,952	0,246
CGM	0,124	0,505	0,276	0,621	-0,807	0,998	-0,417	0,619	0,841	0,593	0,749	0,505
CMI	0,221	0,459	0,372	0,584	-0,711	0,975	-0,321	0,582	0,937	0,555	0,845	0,459
LNE	0,282	0,605	0,433	0,705	-0,650	1,052	-0,260	0,703	0,998	0,681	0,906	0,605
INM	-0,308	1,150	-0,157	1,206	-1,240	1,437	-0,850	1,205	0,408	1,192	0,316	1,150
INRIM	0,054	0,350	0,205	0,504	-0,878	0,929	-0,488	0,501	0,770	0,469	0,679	0,351
NPL	0,142	0,242	0,293	0,435	-0,790	0,894	-0,400	0,432	0,858	0,395	0,766	0,243
NRC	-0,015	0,319	0,136	0,483	-0,946	0,918	-0,556	0,480	0,701	0,446	0,610	0,320
NMIA	0,382	0,637	0,533	0,732	-0,550	1,070	-0,160	0,731	1,098	0,709	1,006	0,637
VNIIM	1,432	1,708	1,583	1,746	0,500	1,912	0,890	1,745	2,148	1,736	2,056	1,708
MIKES			0,151	0,437	-0,932	0,895	-0,542	0,434	0,716	0,396	0,625	0,245
VSL	-0,151	0,437			-1,083	0,965	-0,693	0,565	0,565	0,537	0,473	0,437
GUM	0,932	0,895	1,083	0,965			0,390	0,964	1,648	0,948	1,556	0,895
INMETRO	0,542	0,434	0,693	0,565	-0,390	0,964			1,258	0,534	1,166	0,434
CENAM	-0,716	0,396	-0,565	0,537	-1,648	0,948	-1,258	0,534			-0,092	0,397
CEM4	-0,625	0,245	-0,473	0,437	-1,556	0,895	-1,166	0,434	0,092	0,397		

Gauge 11	BEV		NML		OMH		SP		CEM2		CGM		CMI	
400 mm	$D_{ij} / \mu\text{m}$	$U_{ij} / \mu\text{m}$	$D_{ij} / \mu\text{m}$	$U_{ij} / \mu\text{m}$	$D_{ij} / \mu\text{m}$	$U_{ij} / \mu\text{m}$	$D_{ij} / \mu\text{m}$	$U_{ij} / \mu\text{m}$	$D_{ij} / \mu\text{m}$	$U_{ij} / \mu\text{m}$	$D_{ij} / \mu\text{m}$	$U_{ij} / \mu\text{m}$	$D_{ij} / \mu\text{m}$	$U_{ij} / \mu\text{m}$
BEV			-0,318	2,700	-0,650	1,926	-0,451	1,347	-0,445	1,341	-0,458	1,418	-0,511	1,406
NML	0,318	2,700			-0,333	2,735	-0,133	2,364	-0,127	2,360	-0,140	2,405	-0,193	2,398
OMH	0,650	1,926	0,333	2,735			0,200	1,416	0,206	1,410	0,193	1,483	0,139	1,471
SP	0,451	1,347	0,133	2,364	-0,200	1,416			0,006	0,307	-0,007	0,554	-0,060	0,521
CEM2	0,445	1,341	0,127	2,360	-0,206	1,410	-0,006	0,307			-0,013	0,539	-0,066	0,505
CGM	0,458	1,418	0,140	2,405	-0,193	1,483	0,007	0,554	0,013	0,539			-0,053	0,684
CMI	0,511	1,406	0,193	2,398	-0,139	1,471	0,060	0,521	0,066	0,505	0,053	0,684		
LNE	0,720	1,478	0,403	2,441	0,070	1,541	0,270	0,693	0,276	0,681	0,263	0,823	0,209	0,801
INM	1,120	1,795	0,803	2,645	0,470	1,847	0,670	1,232	0,676	1,226	0,663	1,310	0,609	1,296
INRIM	0,103	1,369	-0,215	2,376	-0,547	1,436	-0,348	0,411	-0,341	0,391	-0,354	0,605	-0,408	0,575
NPL	0,350	1,340	0,033	2,360	-0,300	1,409	-0,100	0,302	-0,094	0,274	-0,107	0,537	-0,161	0,502
NRC	0,304	1,357	-0,014	2,369	-0,347	1,425	-0,147	0,370	-0,141	0,348	-0,154	0,578	-0,207	0,546
NMIA	0,430	1,492	0,113	2,449	-0,220	1,554	-0,020	0,722	-0,014	0,711	-0,027	0,848	-0,081	0,826
VNIIM	3,550	2,209	3,233	2,941	2,900	2,251	3,100	1,782	3,106	1,777	3,093	1,836	3,039	1,827
MIKES	0,298	1,339	-0,020	2,359	-0,353	1,408	-0,153	0,296	-0,147	0,267	-0,160	0,533	-0,213	0,499
VSL	0,127	1,405	-0,190	2,397	-0,523	1,471	-0,323	0,519	-0,317	0,503	-0,330	0,683	-0,384	0,656
GUM	-0,250	1,606	-0,567	2,520	-0,900	1,663	-0,700	0,935	-0,694	0,926	-0,707	1,035	-0,761	1,017
INMETRO	0,230	1,395	-0,087	2,391	-0,420	1,461	-0,220	0,491	-0,214	0,474	-0,227	0,662	-0,281	0,634
CENAM	-0,267	1,377	-0,585	2,381	-0,918	1,444	-0,718	0,439	-0,712	0,420	-0,725	0,624	-0,778	0,595
CEM4	-0,552	1,341	-0,870	2,360	-1,202	1,410	-1,003	0,307	-0,997	0,279	-1,010	0,539	-1,063	0,505

Gauge 11	LNE		INM		INRIM		NPL		NRC		NMIA		VNIIM	
400 mm	$D_{ij} / \mu\text{m}$	$U_{ij} / \mu\text{m}$	$D_{ij} / \mu\text{m}$	$U_{ij} / \mu\text{m}$	$D_{ij} / \mu\text{m}$	$U_{ij} / \mu\text{m}$	$D_{ij} / \mu\text{m}$	$U_{ij} / \mu\text{m}$	$D_{ij} / \mu\text{m}$	$U_{ij} / \mu\text{m}$	$D_{ij} / \mu\text{m}$	$U_{ij} / \mu\text{m}$	$D_{ij} / \mu\text{m}$	$U_{ij} / \mu\text{m}$
BEV	-0,720	1,478	-1,120	1,795	-0,103	1,369	-0,350	1,340	-0,304	1,357	-0,430	1,492	-3,550	2,209
NML	-0,403	2,441	-0,803	2,645	0,215	2,376	-0,033	2,360	0,014	2,369	-0,113	2,449	-3,233	2,941
OMH	-0,070	1,541	-0,470	1,847	0,547	1,436	0,300	1,409	0,347	1,425	0,220	1,554	-2,900	2,251
SP	-0,270	0,693	-0,670	1,232	0,348	0,411	0,100	0,302	0,147	0,370	0,020	0,722	-3,100	1,782
CEM2	-0,276	0,681	-0,676	1,226	0,341	0,391	0,094	0,274	0,141	0,348	0,014	0,711	-3,106	1,777
CGM	-0,263	0,823	-0,663	1,310	0,354	0,605	0,107	0,537	0,154	0,578	0,027	0,848	-3,093	1,836
CMI	-0,209	0,801	-0,609	1,296	0,408	0,575	0,161	0,502	0,207	0,546	0,081	0,826	-3,039	1,827
LNE			-0,400	1,374	0,617	0,734	0,370	0,679	0,417	0,712	0,290	0,944	-2,830	1,883
INM	0,400	1,374			1,017	1,256	0,770	1,225	0,817	1,243	0,690	1,389	-2,430	2,141
INRIM	-0,617	0,734	-1,017	1,256			-0,247	0,387	-0,200	0,442	-0,327	0,762	-3,447	1,798
NPL	-0,370	0,679	-0,770	1,225	0,247	0,387			0,047	0,343	-0,080	0,709	-3,200	1,776
NRC	-0,417	0,712	-0,817	1,243	0,200	0,442	-0,047	0,343			-0,127	0,740	-3,247	1,789
NMIA	-0,290	0,944	-0,690	1,389	0,327	0,762	0,080	0,709	0,127	0,740			-3,120	1,894
VNIIM	2,830	1,883	2,430	2,141	3,447	1,798	3,200	1,776	3,247	1,789	3,120	1,894		
MIKES	-0,423	0,676	-0,823	1,223	0,195	0,382	-0,053	0,262	-0,006	0,338	-0,133	0,706	-3,253	1,775
VSL	-0,593	0,799	-0,993	1,295	0,024	0,573	-0,223	0,500	-0,176	0,544	-0,303	0,825	-3,423	1,826
GUM	-0,970	1,115	-1,370	1,511	-0,353	0,966	-0,600	0,924	-0,553	0,949	-0,680	1,133	-3,800	1,984
INMETRO	-0,490	0,781	-0,890	1,284	0,127	0,547	-0,120	0,471	-0,073	0,518	-0,200	0,808	-3,320	1,818
CENAM	-0,988	0,750	-1,388	1,265	-0,370	0,501	-0,618	0,416	-0,571	0,468	-0,698	0,777	-3,818	1,805
CEM4	-1,272	0,681	-1,672	1,226	-0,655	0,391	-0,902	0,274	-0,856	0,348	-0,982	0,711	-4,102	1,777

Gauge 11	MIKES		VSL		GUM		INMETRO		CENAM		CEM4	
400 mm	$D_{ij} / \mu\text{m}$	$U_{ij} / \mu\text{m}$	$D_{ij} / \mu\text{m}$	$U_{ij} / \mu\text{m}$	$D_{ij} / \mu\text{m}$	$U_{ij} / \mu\text{m}$	$D_{ij} / \mu\text{m}$	$U_{ij} / \mu\text{m}$	$D_{ij} / \mu\text{m}$	$U_{ij} / \mu\text{m}$	$D_{ij} / \mu\text{m}$	$U_{ij} / \mu\text{m}$
BEV	-0,298	1,339	-0,127	1,405	0,250	1,606	-0,230	1,395	0,267	1,377	0,552	1,341
NML	0,020	2,359	0,190	2,397	0,567	2,520	0,087	2,391	0,585	2,381	0,870	2,360
OMH	0,353	1,408	0,523	1,471	0,900	1,663	0,420	1,461	0,918	1,444	1,202	1,410
SP	0,153	0,296	0,323	0,519	0,700	0,935	0,220	0,491	0,718	0,439	1,003	0,307
CEM2	0,147	0,267	0,317	0,503	0,694	0,926	0,214	0,474	0,712	0,420	0,997	0,279
CGM	0,160	0,533	0,330	0,683	0,707	1,035	0,227	0,662	0,725	0,624	1,010	0,539
CMI	0,213	0,499	0,384	0,656	0,761	1,017	0,281	0,634	0,778	0,595	1,063	0,505
LNE	0,423	0,676	0,593	0,799	0,970	1,115	0,490	0,781	0,988	0,750	1,272	0,681
INM	0,823	1,223	0,993	1,295	1,370	1,511	0,890	1,284	1,388	1,265	1,672	1,226
INRIM	-0,195	0,382	-0,024	0,573	0,353	0,966	-0,127	0,547	0,370	0,501	0,655	0,391
NPL	0,053	0,262	0,223	0,500	0,600	0,924	0,120	0,471	0,618	0,416	0,902	0,274
NRC	0,006	0,338	0,176	0,544	0,553	0,949	0,073	0,518	0,571	0,468	0,856	0,348
NMIA	0,133	0,706	0,303	0,825	0,680	1,133	0,200	0,808	0,698	0,777	0,982	0,711
VNIIM	3,253	1,775	3,423	1,826	3,800	1,984	3,320	1,818	3,818	1,805	4,102	1,777
MIKES			0,170	0,497	0,547	0,923	0,067	0,467	0,565	0,412	0,850	0,267
VSL	-0,170	0,497			0,377	1,016	-0,103	0,633	0,395	0,593	0,680	0,503
GUM	-0,547	0,923	-0,377	1,016			-0,480	1,002	0,018	0,978	0,302	0,926
INMETRO	-0,067	0,467	0,103	0,633	0,480	1,002			0,498	0,568	0,782	0,474
CENAM	-0,565	0,412	-0,395	0,593	-0,018	0,978	-0,498	0,568			0,285	0,420
CEM4	-0,850	0,267	-0,680	0,503	-0,302	0,926	-0,782	0,474	-0,285	0,420		

Gauge 11	BEV		NML		OMH		SP		CEM2		CGM		CMI	
420 mm	$D_{ij} / \mu\text{m}$	$U_{ij} / \mu\text{m}$	$D_{ij} / \mu\text{m}$	$U_{ij} / \mu\text{m}$	$D_{ij} / \mu\text{m}$	$U_{ij} / \mu\text{m}$	$D_{ij} / \mu\text{m}$	$U_{ij} / \mu\text{m}$	$D_{ij} / \mu\text{m}$	$U_{ij} / \mu\text{m}$	$D_{ij} / \mu\text{m}$	$U_{ij} / \mu\text{m}$	$D_{ij} / \mu\text{m}$	$U_{ij} / \mu\text{m}$
BEV			-1,023	2,760	-0,808	2,039	-0,774	1,464	-0,861	1,459	-0,677	1,532	-0,867	1,522
NML	1,023	2,760			0,215	2,758	0,248	2,364	0,162	2,361	0,346	2,407	0,156	2,400
OMH	0,808	2,039	-0,215	2,758			0,033	1,459	-0,053	1,454	0,131	1,528	-0,059	1,517
SP	0,774	1,464	-0,248	2,364	-0,033	1,459			-0,086	0,316	0,097	0,566	-0,092	0,536
CEM2	0,861	1,459	-0,162	2,361	0,053	1,454	0,086	0,316			0,184	0,552	-0,006	0,521
CGM	0,677	1,532	-0,346	2,407	-0,131	1,528	-0,097	0,566	-0,184	0,552			-0,190	0,701
CMI	0,867	1,522	-0,156	2,400	0,059	1,517	0,092	0,536	0,006	0,521	0,190	0,701		
LNE	1,078	1,595	0,055	2,447	0,270	1,590	0,303	0,718	0,217	0,707	0,401	0,848	0,211	0,829
INM	0,598	1,901	-0,425	2,657	-0,210	1,897	-0,177	1,259	-0,263	1,252	-0,079	1,337	-0,269	1,325
INRIM	0,599	1,486	-0,424	2,378	-0,209	1,481	-0,176	0,423	-0,262	0,404	-0,079	0,619	-0,268	0,593
NPL	0,748	1,457	-0,275	2,360	-0,060	1,453	-0,027	0,310	-0,113	0,284	0,071	0,548	-0,119	0,518
NRC	0,556	1,473	-0,466	2,370	-0,251	1,469	-0,218	0,379	-0,304	0,357	-0,121	0,590	-0,310	0,562
NMIA	0,928	1,608	-0,095	2,456	0,120	1,604	0,153	0,747	0,067	0,736	0,251	0,873	0,061	0,854
VNIIM	2,508	2,300	1,485	2,956	1,700	2,297	1,733	1,807	1,647	1,802	1,831	1,862	1,641	1,854
MIKES	0,624	1,456	-0,399	2,359	-0,184	1,451	-0,151	0,302	-0,237	0,275	-0,054	0,544	-0,243	0,513
VSL	0,472	1,523	-0,551	2,401	-0,336	1,519	-0,302	0,540	-0,389	0,526	-0,205	0,705	-0,395	0,681
GUM	0,708	1,709	-0,315	2,524	-0,100	1,705	-0,067	0,946	-0,153	0,937	0,031	1,048	-0,159	1,033
INMETRO	0,618	1,511	-0,405	2,393	-0,190	1,506	-0,157	0,504	-0,243	0,488	-0,059	0,677	-0,249	0,653
CENAM	0,121	1,492	-0,902	2,382	-0,687	1,488	-0,653	0,447	-0,740	0,429	-0,556	0,635	-0,746	0,609
CEM4	-0,067	1,459	-1,090	2,361	-0,875	1,454	-0,841	0,316	-0,928	0,290	-0,744	0,552	-0,934	0,521

Gauge 11	LNE		INM		INRIM		NPL		NRC		NMIA		VNIIM	
420 mm	$D_{ij} / \mu\text{m}$	$U_{ij} / \mu\text{m}$	$D_{ij} / \mu\text{m}$	$U_{ij} / \mu\text{m}$	$D_{ij} / \mu\text{m}$	$U_{ij} / \mu\text{m}$	$D_{ij} / \mu\text{m}$	$U_{ij} / \mu\text{m}$	$D_{ij} / \mu\text{m}$	$U_{ij} / \mu\text{m}$	$D_{ij} / \mu\text{m}$	$U_{ij} / \mu\text{m}$	$D_{ij} / \mu\text{m}$	$U_{ij} / \mu\text{m}$
BEV	-1,078	1,595	-0,598	1,901	-0,599	1,486	-0,748	1,457	-0,556	1,473	-0,928	1,608	-2,508	2,300
NML	-0,055	2,447	0,425	2,657	0,424	2,378	0,275	2,360	0,466	2,370	0,095	2,456	-1,485	2,956
OMH	-0,270	1,590	0,210	1,897	0,209	1,481	0,060	1,453	0,251	1,469	-0,120	1,604	-1,700	2,297
SP	-0,303	0,718	0,177	1,259	0,176	0,423	0,027	0,310	0,218	0,379	-0,153	0,747	-1,733	1,807
CEM2	-0,217	0,707	0,263	1,252	0,262	0,404	0,113	0,284	0,304	0,357	-0,067	0,736	-1,647	1,802
CGM	-0,401	0,848	0,079	1,337	0,079	0,619	-0,071	0,548	0,121	0,590	-0,251	0,873	-1,831	1,862
CMI	-0,211	0,829	0,269	1,325	0,268	0,593	0,119	0,518	0,310	0,562	-0,061	0,854	-1,641	1,854
LNE			0,480	1,409	0,479	0,761	0,330	0,704	0,521	0,737	0,150	0,978	-1,430	1,914
INM	-0,480	1,409			-0,001	1,284	-0,150	1,251	0,041	1,270	-0,330	1,424	-1,910	2,175
INRIM	-0,479	0,761	0,001	1,284			-0,149	0,400	0,042	0,455	-0,329	0,788	-1,909	1,824
NPL	-0,330	0,704	0,150	1,251	0,149	0,400			0,191	0,352	-0,180	0,734	-1,760	1,801
NRC	-0,521	0,737	-0,041	1,270	-0,042	0,455	-0,191	0,352			-0,371	0,765	-1,951	1,814
NMIA	-0,150	0,978	0,330	1,424	0,329	0,788	0,180	0,734	0,371	0,765			-1,580	1,925
VNIIM	1,430	1,914	1,910	2,175	1,909	1,824	1,760	1,801	1,951	1,814	1,580	1,925		
MIKES	-0,454	0,701	0,026	1,249	0,025	0,394	-0,124	0,269	0,067	0,345	-0,304	0,730	-1,884	1,800
VSL	-0,606	0,832	-0,126	1,327	-0,127	0,596	-0,276	0,522	-0,084	0,565	-0,456	0,857	-2,036	1,855
GUM	-0,370	1,137	0,110	1,537	0,109	0,979	-0,040	0,935	0,151	0,960	-0,220	1,156	-1,800	2,011
INMETRO	-0,460	0,808	0,020	1,313	0,019	0,564	-0,130	0,485	0,061	0,531	-0,310	0,834	-1,890	1,844
CENAM	-0,957	0,774	-0,477	1,292	-0,478	0,513	-0,627	0,425	-0,435	0,477	-0,807	0,801	-2,387	1,830
CEM4	-1,145	0,707	-0,665	1,252	-0,666	0,404	-0,815	0,284	-0,623	0,357	-0,995	0,736	-2,575	1,802

Gauge 11	MIKES		VSL		GUM		INMETRO		CENAM		CEM4	
420 mm	$D_{ij} / \mu\text{m}$	$U_{ij} / \mu\text{m}$	$D_{ij} / \mu\text{m}$	$U_{ij} / \mu\text{m}$	$D_{ij} / \mu\text{m}$	$U_{ij} / \mu\text{m}$	$D_{ij} / \mu\text{m}$	$U_{ij} / \mu\text{m}$	$D_{ij} / \mu\text{m}$	$U_{ij} / \mu\text{m}$	$D_{ij} / \mu\text{m}$	$U_{ij} / \mu\text{m}$
BEV	-0,624	1,456	-0,472	1,523	-0,708	1,709	-0,618	1,511	-0,121	1,492	0,067	1,459
NML	0,399	2,359	0,551	2,401	0,315	2,524	0,405	2,393	0,902	2,382	1,090	2,361
OMH	0,184	1,451	0,336	1,519	0,100	1,705	0,190	1,506	0,687	1,488	0,875	1,454
SP	0,151	0,302	0,302	0,540	0,067	0,946	0,157	0,504	0,653	0,447	0,841	0,316
CEM2	0,237	0,275	0,389	0,526	0,153	0,937	0,243	0,488	0,740	0,429	0,928	0,290
CGM	0,054	0,544	0,205	0,705	-0,031	1,048	0,059	0,677	0,556	0,635	0,744	0,552
CMI	0,243	0,513	0,395	0,681	0,159	1,033	0,249	0,653	0,746	0,609	0,934	0,521
LNE	0,454	0,701	0,606	0,832	0,370	1,137	0,460	0,808	0,957	0,774	1,145	0,707
INM	-0,026	1,249	0,126	1,327	-0,110	1,537	-0,020	1,313	0,477	1,292	0,665	1,252
INRIM	-0,025	0,394	0,127	0,596	-0,109	0,979	-0,019	0,564	0,478	0,513	0,666	0,404
NPL	0,124	0,269	0,276	0,522	0,040	0,935	0,130	0,485	0,627	0,425	0,815	0,284
NRC	-0,067	0,345	0,084	0,565	-0,151	0,960	-0,061	0,531	0,435	0,477	0,623	0,357
NMIA	0,304	0,730	0,456	0,857	0,220	1,156	0,310	0,834	0,807	0,801	0,995	0,736
VNIIM	1,884	1,800	2,036	1,855	1,800	2,011	1,890	1,844	2,387	1,830	2,575	1,802
MIKES			0,152	0,517	-0,084	0,933	0,006	0,479	0,503	0,419	0,691	0,275
VSL	-0,152	0,517			-0,236	1,035	-0,146	0,656	0,351	0,613	0,539	0,526
GUM	0,084	0,933	0,236	1,035			0,090	1,016	0,587	0,989	0,775	0,937
INMETRO	-0,006	0,479	0,146	0,656	-0,090	1,016			0,497	0,581	0,685	0,488
CENAM	-0,503	0,419	-0,351	0,613	-0,587	0,989	-0,497	0,581			0,188	0,429
CEM4	-0,691	0,275	-0,539	0,526	-0,775	0,937	-0,685	0,488	-0,188	0,429		

13 Conclusions

This comparison involved 19 laboratories from 4 different metrological regions all over the World.

Comparison lasted 3 years, since December 2004 to December 2007; although mostly according to the schedule, there were some shifts and delays as indicated in Table 2.

Some minor damages were observed by participants and, in those cases of Labs. re-measuring the gauge, they noticed some shift in the position of some gauges. This phenomenon was also observed by the Pilot Lab. when re-measuring the step and when looking at the participants' results, after receiving all measurement data.

Because the first face of the first gauge is the origin of measurements, it results for the 420 mm step 21 measuring faces from which the participants sent their deviations to nominal positions and the uncertainties of such deviations.

The analysis of data follows the document CIPM_MRA-D-05 "Measurement comparisons in the CIPM MRA" and the *Recommendations of the Consultative Committee for Length (CCL) regarding strategies for evaluating key comparison data*, as discussed at CCL-WGDM Workshop in September 2005^[3].

Because the lack of stability observed in some of the gauges of the step, in order to save the comparison and get valuable and useful conclusions, the following **actions** were taken:

- **To exclude gauges 5, 7, 8 and 10 from calculation**, based on the large variations and anomalous behaviour observed on them by the Pilot Lab. and the participants (Fig. 7).
- **Assume that only gauges 1, 2, 3, 4, 6, 9 and 11 are reasonably stable** along the comparison and use them for the analysis, trying to get the corresponding reference values (RVs). Although there is a reduction in the number of gauges, the number of remaining ones is still valid for checking the capability of participants to calibrate step gauges according to their CMCs.
- **To leave out the results of CENAM and CEM4 and analyze them separately** as a second group, linking later their results to the main group. So, taking CEM4 as linking lab. it is the only way to get conclusions on the capability of CENAM to realize this type of calibrations.

Just after the approval of Draft B report as Final Report, INRIM detected that the standard uncertainty values given in Table 5 (page 21) did not correspond to the standard uncertainty equation indicated in the table at page 20, but to expanded uncertainty (U_{95}) values. So, Table 5 was consequently corrected to show the right INRIM u (1σ) values. As a consequence, all comparison figures were recalculated by the Pilot, showing final negligible variations, with all participants maintaining the level of consistency they had before such correction, including INRIM.

The conclusion is that the compatibility of all participants for measuring step gauges has been demonstrated, getting only 1 anomalous value for OMH (100 mm) and two for INMETRO (200 mm, 220 mm). This represents a high percentage of valid values with respect to the full set of 13 values. *The only exception was VNIIM which only obtained three compatible values, showing very big systematic errors for the rest of gauges and, curiously, sometimes positive, sometimes negative.*

The author of the report thanks all participants for their measurements and patient along the full process of measuring and reporting, and specially to Nick Brown (NMIA), Andrew Lewis (NPL), Michael Matus (BEV) and Antti Lassila (MIKES) for their very useful advices, the last one with a key contribution for best analyzing the results by dividing them in two 'stable' groups.

^[3] Jennifer E Decker, N Brown, Maurice G Cox, A G Steele and R J Douglas, *Metrologia* **43** (2006) L51–L55

14 Annex A: Measurement methods and instruments used by the participants

A wide variety of instruments and techniques were used to make measurements of the step gauge. The most important details of instruments and techniques of those participants who sent this information (unfortunately not all of them) are reported here.

BEV

Make and type of instrument

SIP 3002 length measuring machine with a standard laser interferometer only (i.e. no internal scale.) The probing system was a modified system, normally used for screw pitch determination.



Traceability path (scale, interferometer, calibration std.):

HP 5529A Laser interferometer system with standard linear interferometer and Agilent 10751D air sensor. All systems calibrated by the BEV.

Description of the measuring technique:

With the instrument used it is only possible to measure the distance of equally oriented faces. Consequently two sets of distances were first determined, denoted L_i and R_i , respectively.

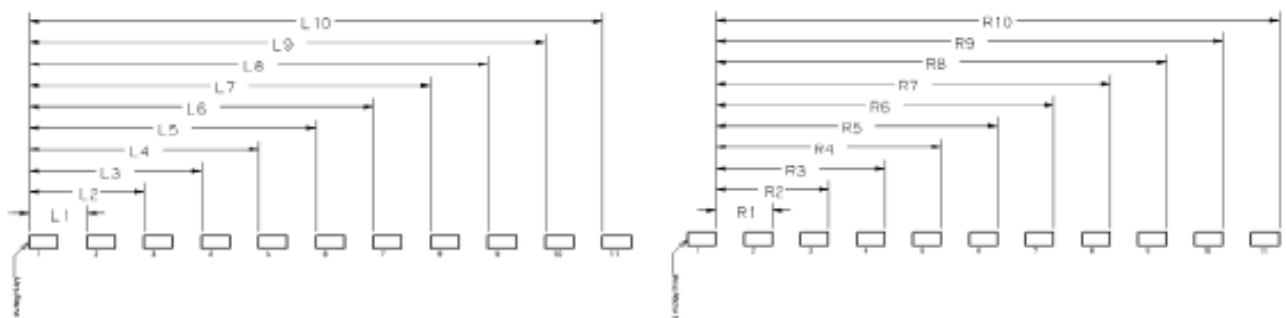

To combine these two sets, at least one additional gap measurement is necessary. In fact 4 different gaps were measured according to the method normally used in ring gage calibrations.



As an internal check the distance B1 was also measured (like a gap gauge). The five results were adjusted in a classical way.

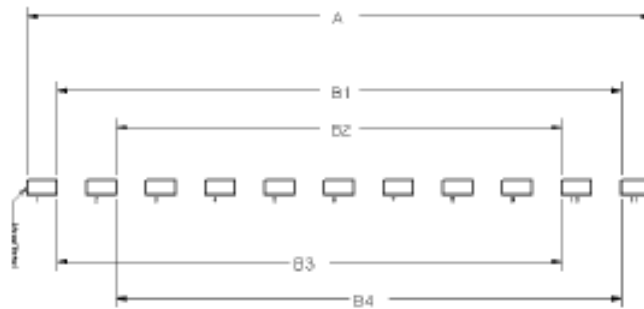

Range of artefact temperature during measurements & description of temperature measurement method:

19,79 °C – 20,09 °C

Three surface temperature sensors (Agilent 10757), magnetically fixed to the artefact.

LNE

Make and type of instrument

Length Measuring machine designed by SIP (SIP F1A) as shown by the following photo



This machine has an X movement on which the axe of the step gauge is aligned and a vertical movement, in order to enter to the centre line.

On this vertical axe an inductive probe Cary 1-Dim is mounted.

Traceability path (scale, interferometer, calibration std.):

Displacement measurement using HP laser interferometer.

Probe diameter calibration using a 20 mm gauge block, which is placed on the axis defined by the centre line.

Description of the measuring technique:

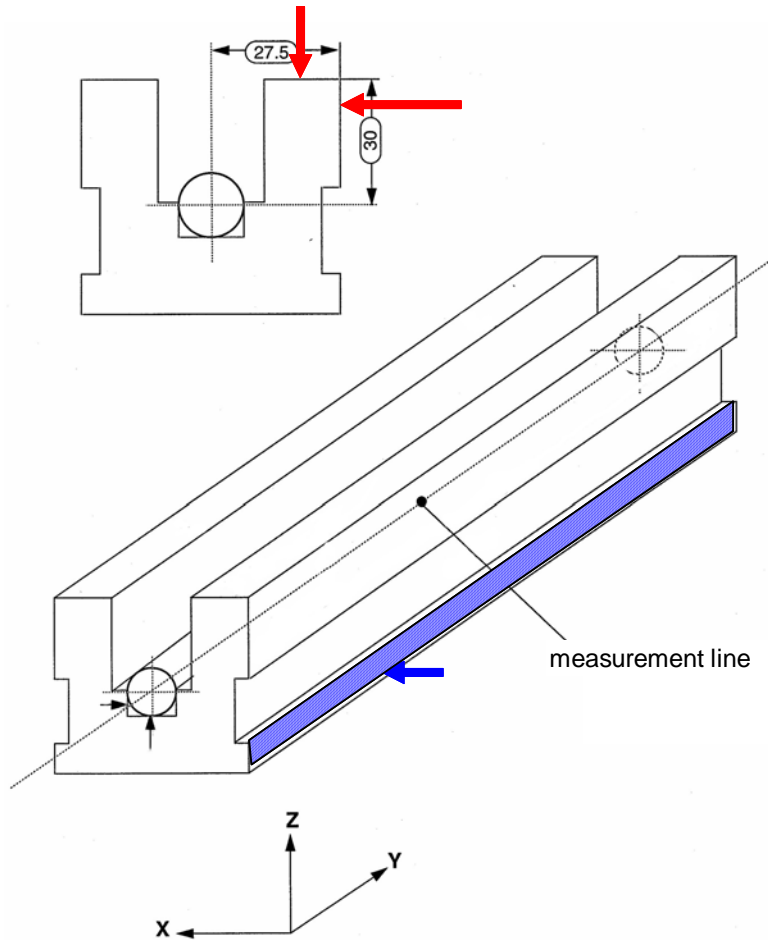

Alignment of the step gauge: as shown on the drawing above, the centre line is given by the two faces (red arrows) of the step gauge, at 27.5 mm in horizontal direction and 30 mm in vertical direction.

The step gauge is aligned using the external face (bottom right) as shown by the blue surface.

The step gauge is put on two gauge block with glue in order to avoid any strain and any movement during calibration.

The first step consists in measuring the gauge block in order to determine the radius and probe bending of the probe.

The polarisation beam splitter is fixed on the machine as the corner cube is moving on the table with the step gauge ; the beam laser is in the plane of the centre line (Abbe principle).

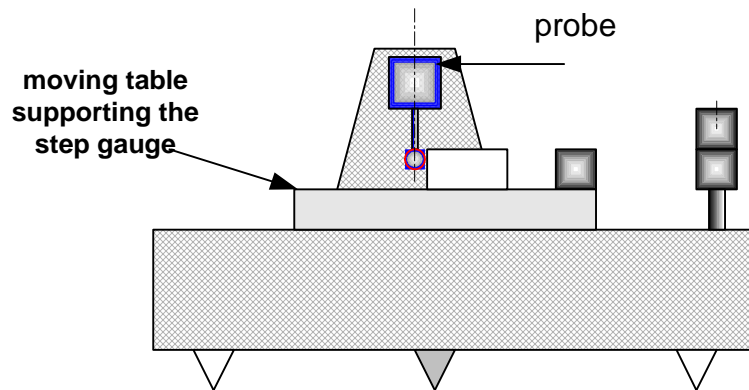

Range of artefact temperature during measurements & description of temperature measurement method:

The temperature sensors are those of the laser interferometer. Two probes are fixed on the step gauge. Temperature during measurement was between 19,9 °C and 20,1 °C.

OMH

Make and type of instrument:

Coordinate Measuring Machine SIP CMM 5, No: 502

Traceability path (scale, interferometer, calibration std.):

Gauge blocks calibrated by interference method

Description of the measuring technique:

1. Coordinate system determination according to the description
2. Points corrected by the styli ball diameter
3. x coordinates of the points

Range of artefact temperature during measurements & description of temperature measurement method:

Between 19.11 °C and 20.57 °C while all the measurements

Pt 100 sensors calibrated by the OMH temperature department.

SP

Description of the measurement instrument:

The measurements were made in a specially designed (non-commercial) measuring bench, based on a movable carriage with an air-flow bearing on a granite surface. A laser interferometer with a tilt compensating beam path measures the distance to the inductive probe system. The probe constant is determined prior to each series by means of a calibrated gauge block and the environment data is collected for each measuring point.

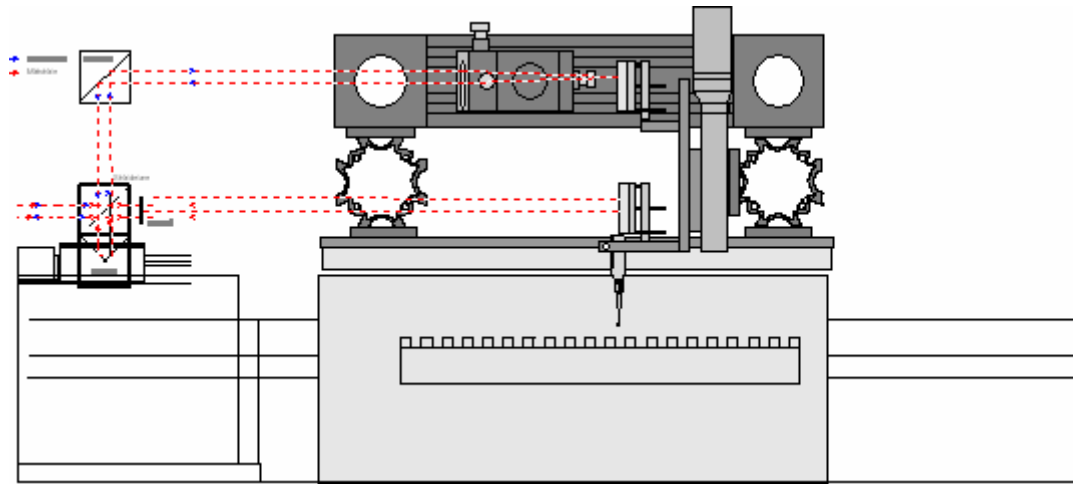

Traceability path:

The laser interferometer is calibrated directly against the Swedish primary length standard (I_2 -stabilized HeNe laser). The probe is calibrated through the laser.

Description of the measuring technique:

The alignment of the step gauge was made on the side-walls using a dial test indicator with 0,01 mm resolution (analogue). The step gauge was supported in the Bessel points.

The measurements were carried out along an axis which passes through the centre of the measuring face No. 0 and is parallel to both the bottom face and the side alignment face.

A computer controlled program measures each surface with a probe deviation $< 1 \mu\text{m}$. The result is the combination of laser and probe reading and corrected for environment data and the probe constant.

Range of artefact temperature during measurements & description of temperature measurement method:

Measurements were made in a temperature range of $(20,0 \pm 0,5) ^\circ\text{C}$

The temperature was measured with 5 Pt 100 sensors attached to the frame of the object at equal distances.

NPL

Make and type of instrument

The measurements were made using an NPL designed laser interferometer system. This interferometer system, known at NPL as 'The Step Gauge Rig' is an instrument specifically designed for the measurement of precision step gauges. It features interferometric measurement of a moving probe, from two opposing directions simultaneously, with both measurements referred to one end of the step gauge.

The Step Gauge Rig is mounted on a Leitz PMM 12106 high accuracy Coordinate Measuring Machine to provide probe positioning, and is located in a temperature and humidity controlled room, with nominal control of $\pm 0.2 ^\circ\text{C}$ and $\pm 5 \% \text{RH}$.

The instrument uses two interferometers: a displacement interferometer and a column reference displacement interferometer. The reference beam for the column reference interferometer is reflected from a

mirror at the other end of the instrument, near to the primary interferometer. The primary interferometer is mounted on an Invar plate which is in sprung contact with the 'zero' end of the step gauge. This compensates for any thermal expansion of the mounting rig. A conventional CMM probe is used but with two mirrors mounted onto the probe stem, each mirror facing one interferometer. This allows the position of the CMM probe to be measured with respect to the step gauge end face, from two directions simultaneously, to compensate for air path variations. Both interferometers allow both displacement and tilt measurement, so any tilting of the probe stem can be compensated for. Measurements are made of air temperature (at several locations), pressure and humidity, and the refractive index correction is calculated from this data. Probe ball diameter is calibrated by using the probe to measure a small reference gauge block (pre-calibrated by interferometry) which is mounted at the measurement axis height of the system.

Temperature measurements were made using a total of five calibrated PRTs; two PRTs in contact with and located at either end of the gauge, two PRTs monitoring the air temperature close to the measurement line at both ends of the gauge and one PRT in contact with a reference gauge block used for probe ball diameter calibration.



Fig 1. Measurement of a step gauge using the Step Gauge Rig mounted on the Leitz CMM

Traceability path (scale, interferometer, calibration std.):

Interferometry: The interferometer system upon which the NPL Step Gauge Rig is based uses commercial (Zygo) optics and stabilised laser. The frequency of the stabilised laser had been calibrated against an iodine stabilised laser which serves as one of the realisations of the metre for the UK. The diameter of the probe ball used to contact the gauge insert faces was calibrated directly against the interferometer and a small gauge block which had been calibrated using multiple-wavelength interferometry using stabilised lasers.

Temperature: The PRTs had been calibrated to ITS-90 specifications using the water triple point and gallium melting points.

Description of the measuring technique:

The step gauge was seated on two precision alignment saddles mounted on the test rig and located at the gauge Bessel points. The step gauge was positioned with the measurement axis nominally aligned with the interferometer measurement beams.

The measurement line was defined using the side and bottom faces of the insert locating slot, by probing with the CMM probe. The vertical alignment of the gauge was defined by probing the bottom of the insert slot

Within this coordinate system, probing points were generated along the measurement line, on each face of the step gauge, nominally at the centre of each face. After allowing the system and artefact to stabilise over a number of hours, the measurement process was started under automatic computer control. Firstly, the gauge block was measured in order to determine the probe ball diameter. This measurement was made comparing the interferometer readings with the pre-calibrated length of the gauge block. After probing the gauge block, the probe was used to measure the distance from the datum face to each of the remaining faces of the step gauge, in turn. The measurement sequence was such that data was recorded on both the outwards and return directions of the probe along the step.

The measurement process was repeated a further four times with the reported distances being the mean of five outward and five return measurements. The measurement data was corrected for deviation from 20 °C.

Range of artefact temperature during measurements & description of temperature measurement method:

Temperature measurements were made using a total of five calibrated PRTs; two PRTs in contact with and located at either end of the gauge, two PRTs monitoring the air temperature close to the measurement line at both ends of the gauge and one PRT in contact with a reference gauge block used for probe ball diameter calibration.

The thermal expansion coefficient α of the gauge was taken to be $\alpha = 11.5 \times 10^{-6} \text{ K}^{-1}$, as defined in Technical Protocol Key Comparison EUROMET.L-K5.2004. Reported measurements are corrected to a reference temperature of 20 °C using the thermal expansion coefficient provided.

Temperature range during first set of measurements: 20.002 °C to 20.044 °C

Temperature range during second set of measurements: 20.059 °C to 20.122 °C

Reasons for NPL making two measurements of the step gauge:

After the measurements made in August 2005, it was discovered that the alignment procedure of the Step Gauge Rig was not sufficient to guarantee that the laser beam was aligned well enough with the measurement direction, to reduce the misalignment error to a sufficiently small quantity, when measuring the key comparison artefact. NPL contacted the pilot and informed him that the NPL data may have been subject to a misalignment. NPL requested a re-measurement of the step gauge, which was agreed, and NPL made re-measurements in March 2006, with a more rigorous alignment procedure being used. Both measurements were made 'blind' i.e. with no knowledge of other participants' results.

Because the potential size of the misalignment error of the first set of results is unknown, the uncertainties for the first set of results has not been changed, however it is possible that there is an additional length dependent error present in this data.

NPL submits both sets of measurements, but believes that the second set is more representative of its step gauge measurement service's performance.

DANIAMet-CGM

Make and type of instrument

Zeiss UPMC 850 CARAT coordinate measuring machine with static measuring probe (scanning measuring head).

8 mm probe with 0.1 N probing force, without correction for zero measuring force.

Temperature compensation was activated using the two CMM sensors on the artefact with $\alpha = 11.5 \times 10^{-6} \text{ K}^{-1}$

Traceability path (scale, interferometer, calibration std.):

Koba-step 420 mm serial n. 890721/18

Calibration certificate by Carl Zeiss Oberkochen 04-06 dated 23-06-2004

Description of the measuring technique:

A requirement of the comparison was “independent traceability to the realization of the metre” (point 2.1.2 of the Technical Protocol). This was not possible for CGM, since the CMM axis was calibrated using a step gauge from CGM, with the same nominal specifications. The coordinator has been informed before joining the comparison.

The L-K5 step gauge to be calibrated and the calibrated one from CGM were placed on the granite table parallel to the first kinematic axis of the CMM. Mechanical alignment was better than 0.4 mm/m

Measurement sequence:

- Measurement of CGM step gauge, repetition 1
- Measurement of L-K5 step gauge, repetition 1
- Measurement of CGM step gauge, repetition 2
- Measurement of L-K5 step gauge, repetition 2
- Measurement of CGM step gauge, repetition 3
- Measurement of L-K5 step gauge, repetition 3
- Measurement of CGM step gauge, repetition 4
- Measurement of L-K5 step gauge, repetition 4
- Measurement of CGM step gauge, repetition 5
- Measurement of L-K5 step gauge, repetition 5

The CMM axis was calibrated using the measurement data from the CGM step gauge (5 repetitions) and its calibration certificate.

The L-K5 step gauge was measured with 5 repetitions using the calibrated CMM axis. Total measurement time was two hours.

Range of artefact temperature during measurements & description of temperature measurement method:

The temperature was monitored using a temperature measuring system based on Pt 100 sensors with a calibration uncertainty of 0.02 K.

Two air sensors were measuring the temperature of air surrounding the artefact.

Two material sensors were attached to the artefact, one in front and one on the back as shown in the following picture:

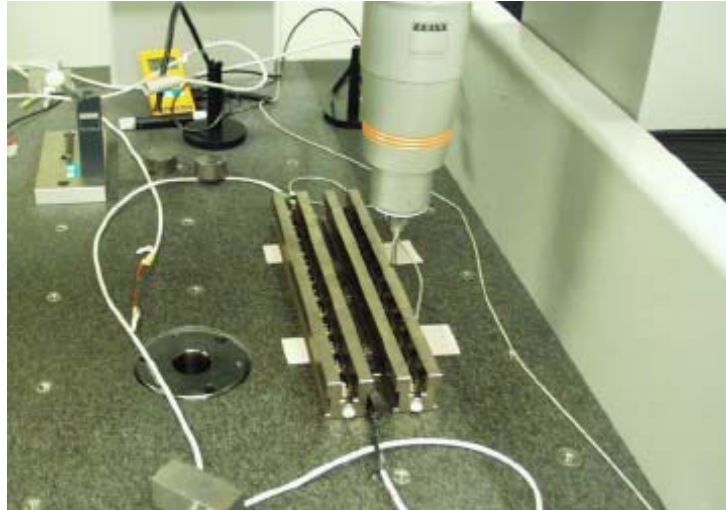

The range of artefact temperature during measurements was 0.05 K

The range of air temperature was 0.25 K

Average temperature of artefact during measurement was 20.13 °C

CMI

Make and type of instrument:

Coordinate measuring machine SIP CMM5 No. 603, additional probe with linear sensor and plane mirror was used. Measurement was performed using laser interferometer Renishaw with linear optics with lambda/4 plate. The procedure with extrapolation of measuring force to zero was applied.

Traceability path:

CMM with direct use of laser interferometer calibrated by iodine stabilized laser, environment sensors traceable to relevant national standards.

Description of the measuring technique:

The artefact and the laser beam were aligned parallel to moving axis of the CMM. To determine a diameter of the probe, the reference gauge blocks were measured. Each face was touched with the probe in ten steps, in these steps the program always read current position of the probe and the value from the interferometer together in the same time. Afterwards the calculation of zero force was performed to obtain contact point. The final values are average from ten repeated measurements.

Range of artefact temperature during measurements & description of temperature measurement method:

All the measurements were performed in the range of (19.92 to 20.06) °C. The range of temperature during one measurement loop was not bigger than 0.05 °C. The standard Renishaw ML10 compensation unit with material sensors was used. The offset of material sensors from their calibration was compensated (+0.05 °C).

INRIM

Make and type of instrument

The measuring apparatus is based on a Moore Measuring Machine, modified at IMGC, equipped with a laser interferometer and a proportional contact probe (CARY mod. I-DIM).

Tab. 1. Instrument/room identification.

Instrument	Manufacturer	Model
Universal Measuring Machine	Moore	n. 3
LVDT Probe (stylus 40 mm with ruby sphere dia. 3 mm)	CARY	I-DIM
Gauge block	Cary	10 mm
Laser interferometer	HP	5517B
Barometer	Rosemount	A F1B1A1A
Hygrometer	Michell	S3000
Thermometer (with six Pt 100 Minco)	Corradi	RP7000
Laboratory with filtered air (not classified clean room class)	-	-

Traceability path (scale, interferometer, calibration std.):

The laser interferometer (λ_0) is calibrated with reference to the national length standard (laser He-Ne ($^{127}\text{I}_2$)).

A calibrated gauge block is used for the characterization (probe diameter, displacement sensitivity) of the contact probe.

The measurements of the ambient parameters (temperature, pressure and humidity) and of the temperature of step gauge are traceable to the national standards.

Description of the measuring technique:

In the measurement procedure the contact probe is used to determine the positions (left- and right-sides) of the faces of the gauges/cylinders from combined LVDT probe readings and interferometric displacement measurements. The (centre) face position is obtained from the interferometer and probe readings when the probe is in contact with the gauge face. The probe-surface load is of about 3 mN.

The diameter of the probing sphere (made of ruby) and the sensitivity of the LVDT probe are calibrated using a certified gauge block mounted on the moving table/support of the Moore Machine. This measurement is repeated within and between the measurement runs on the step-gauge.

The measurement results have been appropriately corrected to the reference temperature of 20 °C using the given value of the thermal expansion coefficient.

The equipment configuration from bottom up was: Moore carriage, tilt stage and height adapters up to Abbe condition in vertical/lateral and base support of the step gauge (Bessel support points).

The applied procedure is the following:

The step height is placed on the base support and is aligned (visually) with the displacement axis and the measuring (laser) axis. Then, the step height is aligned along the vertical and y lateral axes, to minimize the Abbe offset between the laser beam and the centre of the cylinders/gauges of the step height.

The step gauge is further aligned by touching with the probe the upper and lateral reference surfaces of the step-gauge when moving forth and back several times the x axis of the measuring machine. Due to mechanical constraints we could not use the bottom face of the groove where the gauges are fixed.

For the determination of the centre of the gauges/cylinders we used a sphere of known diameter placed in the upper surface of the step-gauge and aligned to its external lateral side. Then, we search with the probe the centre of the sphere in the Y and Z directions and so we know the position of the upper and side surfaces of the step-gauge, from which we may position the measuring line at the centre of the gauge/cylinder.

With the automatic control of the Moore machine, no manual handling of the step height is required to reset the equipment between each set of measurements.

The adopted measurement strategy is:

1. The positions of the left- and right-side faces of the cylinders/gauges (step gauge oriented along the x-axis - orientation 0°) from 6 measurement runs (forth and back paths for each run);
2. The positions of the left- and right-side faces of the cylinders/gauges (step gauge rotated of 180° in the xy plane, i.e., oriented along the x-axis - orientation 180°) from 6 measurement runs (forth and back paths for each run);

For each run the deviation from the nominal length is obtained from the average of forward and backward measurements of the face positions.

Range of artefact temperature during measurements & description of temperature measurement method:

The range of artefact temperature during the measurement runs was from 19.97 °C to 20.05 °C. The temperatures of the ambient air (2 thermometers along the measuring path) and of the artefact (2 thermometers) are measured with a bridge-type temperature analyser operating with up to six Pt 100 resistance thermometers. Temperatures are taken about every 10 minutes during the full measurement run (about 2 hours).

NMIA

Description of the measurement instrument:

Coordinate Measuring Machine – Leitz PMM866 fitted with a four pass laser interferometer measuring system¹, designed to reduce Abbe errors. (note that the uncertainty of the measurement in reference 1 was not used in this report.)

Traceability path (scale, interferometer, calibration std.):

The frequency of the laser interferometer is traceable to the Australian national standard of length. The temperature sensors, pressure sensor and humidity sensor are all traceable to their respective Australian national standards. The scales of the CMM have been calibrated by the laser interferometer. The CMM probe diameter was determined by measuring the length of a length bar which is traceable to the Australian standard of length.

Description of measuring technique:

The laser interferometer was aligned to the motion of the major axis of the CMM using a quadrant photo detector. A laser interferometer was attached to the probe head by mounting two flat mirrors on either side of the probe head. Each mirror functioned as a two-pass interferometer so the probe was in the centre of four measurement beams, thus reducing the Abbe errors (see Figure 1 and reference (1) below).

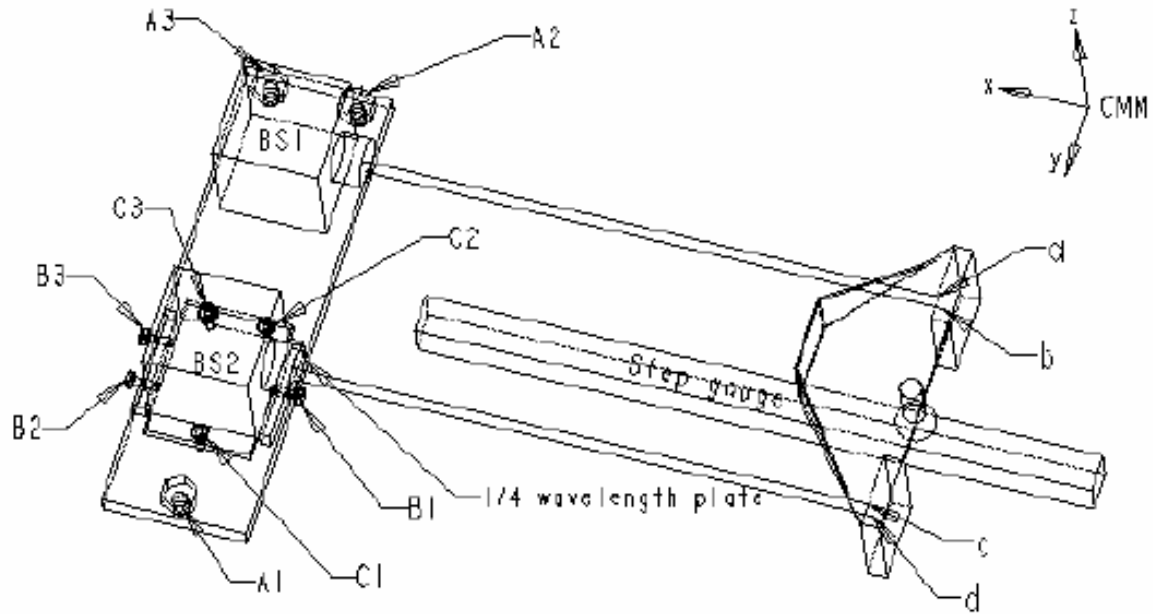

Figure 1 Diagram of 4-pass interferometer

Probing the gauge surface was achieved by positioning the CMM probe $50\ \mu\text{m}$ from the gauge surface and then moving it in $5\ \mu\text{m}$ steps a distance of $0.1\ \text{mm}$ towards (and past) the surface. Zero force contact with the gauge surface was obtained by fitting linear functions to the approach and contact portions of the position data (Figure 2).

Six readings were taken on each measurement face of the step gauge. The diameter of the CMM probe was determined by replacing the step gauge with a calibrated length bar and comparing the CMM/laser interferometer measurements with the calibrated length of the step gauge.

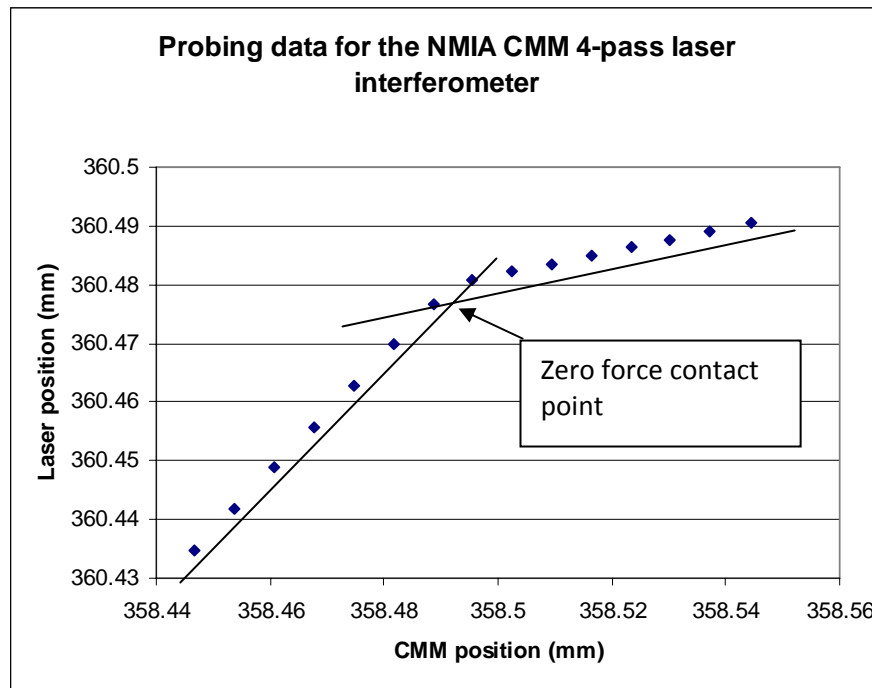

Figure 2. Position data used to determine a typical surface contact.

Range of artefact temperature during measurements & description of temperature measurement method:

Measurements were made over the temperature range 19.85 °C to 20.05 °C. five temperature probes were attached to the step gauge – two probes each close to the b1 and b2 markings, and one in the middle. The temperatures were recorded continuously during the measurement. A single probe recorded the air temperature near the laser beam path.

MIKES

Make and type of instrument:

Self constructed automatic length measuring machine for step gauge calibration was set up on a 3-m long steel straightness guide with horizontal and vertical reference surfaces (see figure 1.). Measured straightness deviation of the guide is within $\pm 2.5 \mu\text{m}$ over the total range. A carriage with inductive probe (Mahr Millimar 1320/1) can be moved on guide using lead screw and stepper motor. Fine tuning of the probe ball position is made with a piezo actuator. The position of the ball is measured using a heterodyne laser interferometer (HP 5528). The probe lifts up and down using two small pneumatic cylinders. The probe ball with extension rod can be lifted so that the laser interference signal is not lost. The measurement line of the interferometer is adjusted coaxial with movement axis of the ball in order to minimise Abbe error. Ambient conditions (air and material temperature, air pressure and humidity) are measured on line. Three Pt 100 sensors are used for material temperature measurement and two for air temperature measurement. Refractive index of air is calculated using updated Edlen’s equation by Bönsch [1]. Nominal probe ball diameter is 3 mm. The calibration sequence is fully controlled by a PC.

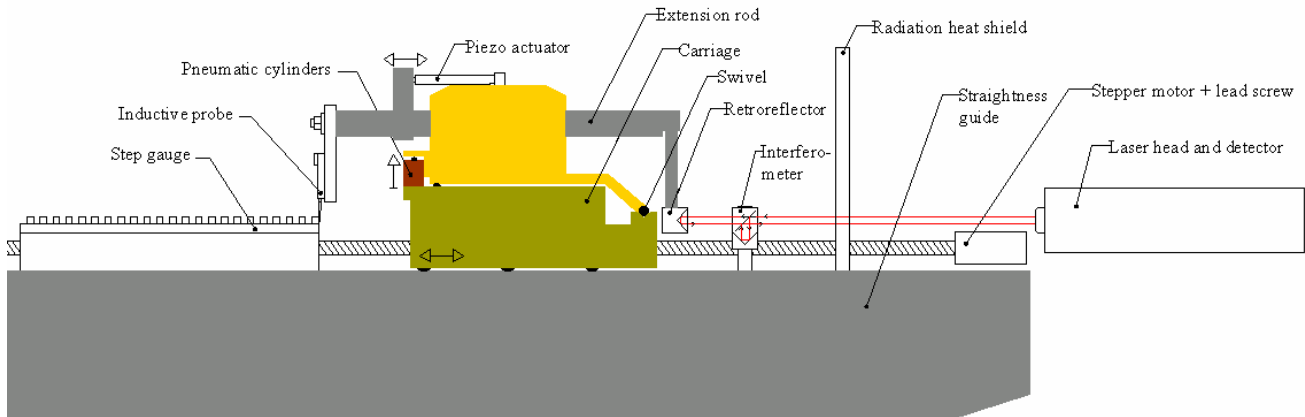

Figure 1. Sketch of MIKES' interferometric step gauge calibration set-up.

Traceability path (scale, interferometer, calibration std.):

Frequency of the laser (HP 5518) was calibrated against an Iodine stabilized laser MRI3 operating at 633 nm.

The pressure meter (Vaisala PTU 200) was calibrated against MIKES reference pressure balance.

The humidity meter (Vaisala PTU 200) was calibrated against MIKES reference humidity generator.

The temperature meter (Keithley 2010 + 5 Pt 100 sensors) was calibrated in water path against reference Platinum Resistance Thermometer Pt 25. For air temperature measurement self heating of sensors was estimated and corrected.

The diameter of the probe ball was calibrated by measuring an interferometrically calibrated gauge block with at same set up. The calibration was checked also with an internal length reference which was formed by three gauge blocks wrung to each other.

Description of the measuring technique:

Gauge surfaces were detected with the inductive probe so that the deflection of the probe was $(1.00 \pm 0.05) \mu\text{m}$ (measuring force 0.0035 N). The laser interferometer reading and the ambient conditions were recorded concurrently. Five runs covering all surfaces were made for one set of measurements. Measurements were repeated when the step gauge was turned 180° .

Range of artefact temperature during measurements & description of temperature measurement method:

$(19,88 - 20,08) ^\circ\text{C}$. Material temperature was measured using three Pt 100 sensors. Temperature data were recorded with 50 seconds interval. The latest material temperature value was used for thermal expansion compensation in connection with every measured surface position.

[1] Bönsch, G. et al., (1998) 'Measurement of the refractive index of air and comparison with modified Edlén's...' Metrologia 35, 133-139.

VSL

Description of the measurement instrument

The measurements on the step gauge are carried out using the following equipment:

Device:	Coordinate Measuring Machine
Model:	UC550
Manufacturer:	Zeiss
Measuring volume:	1200x550x450 mm ³
Software:	UMESS-Basic + UX (2001), validated by PTB

The CMM has been equipped with a 1D Interferometer in order to ensure direct traceability and a higher accuracy for 1D measurements.

Laser:	Stabilized HeNe-Laser
Model:	5528 A
Manufacturer:	Hewlett Packard

The laser system has a double pass (flat mirror) configuration. The CMM is only used as an accurate positioning and probing machine.

Traceability path (scale, interferometer, calibration std.):

Traceability is ensured by using a stabilized HeNe laser for the length measurements. This laser is directly calibrated to the national primary length standard.

Description of the measuring technique:

First of all the alignment of the laser system along one of the axis of the machine is performed; subsequently the step gauge is aligned in 2 orthogonal directions to the same machine axis. Then the measurement line determined on which the measurements are performed. As well at the beginning as at the end of the measurement series the probe constant (effective probe diameter) has been determined on a calibrated 10 mm gauge block.

The measurements have been performed by manual operation of the CMM. The step gauge is measured 7 times in order to determine the reproducibility of the process. Before each measurement of the step gauge the alignment process is repeated.

Range of artefact temperature during measurements & description of temperature measurement method:

Two series of 7 measurements have been executed at the following temperature ranges of the step gauge:

Serie 1: Temperature range step gauge: (19.90 – 19.85) °C

Serie 2: Temperature range step gauge: (20.03 – 20.01) °C

The temperature measurements have been performed using Pt 100 sensors with a Prema 6000 digital multimeter. The temperature of the step gauge is measured with 5 sensors evenly distributed over the step gauge. Of the 5 sensors the average value is used to correct the measured length to the reference temperature of 20.00 °C. The drift of the average temperature and the temperature gradient on the step gauge during the measurements is calculated and accounted for in the uncertainty. The maximum drift occurred is 0.013 °C; the maximum spread in the 5 sensors on the step gauge is 0.070 °C. The standard uncertainty of the temperature measurement (including calibration uncertainty of the sensors, resolution and drift in time of the sensors) is 0.013 °C

GUM

Mark and type of instrument:

Coordinate measuring machine SIP CMM5 N° 302 with new operating system and new software „Metrolog” version 4.0. Manufacturer: SIP firm, Switzerland,

Measuring range: 700 mm along X axis, 500 mm along Y axis, 500 mm along Z axis.

Traceability path (scale, interferometer, calibration std.):

Gauge blocks (20 mm, 100 mm, 150 mm, 200 mm, 250 mm, 300 mm and 400 mm in length) were used as traceability to the unit of metre. Gauge blocks (150 mm, 200 mm, 250 mm, 300 mm and 400 mm in length) were calibrated in PTB (Germany) too.

Description of the measuring technique:

The step gauge supported on Bessel points was measured both along X and Y axes of the machine in centre of the measuring plane XY as showed on Fig.1 in order to eliminate angle error between axes of the machine. Respective distances between successive points along line linking the centres of measuring surfaces were measured.

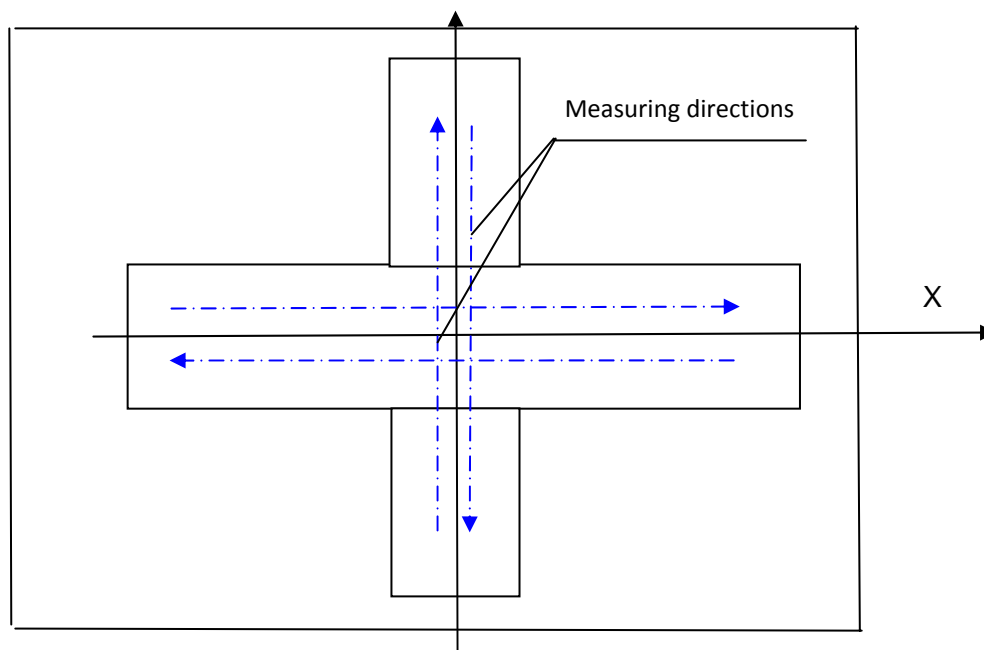

Fig.1. Orientation of the step gauge on measuring table of the machine.

Every time after measuring of the step gauge along one of the axis of the machine several step gauges (20 mm, 100 mm, 150 mm, 250 mm, 300 mm and 400 mm in length) were measured using the same but corrected program such as was used during measurements of step gauge. Before every measurement along one of the axis of the measuring machine alignment procedure was performed (one axis of the machine accordingly to the side non measuring surface of the step gauge, second axis accordingly to the upper non measuring surface of the step gauge and zero set at centre point of the first measuring surface of the step gauge). The gauge blocks were used as traceability to the unit of meter and for introducing linear corrections to the results. The

respective distances between successive points were measured in both measuring directions. Mean values of the respective distances between measuring surfaces calculated from two orientations of the step gauge and two measuring directions after introducing linear corrections were accepted as a final results.

Range of artefact temperature during measurements & description of temperature measurement method:

Range of artefact temperature during measurements: (20.00 ÷ 20.08) °C.

The machine is equipped with five temperature probes Pt 100 for automatic temperature compensation during measurement. Three of them compensate temperature of incremental gauges of the machine along X, Y and Z axes. Two temperature probes are applied for measuring temperature of the artefact. During measurement of the step gauge the temperature probes were fixed near the first and the last surfaces.

INMETRO

Description of the measurement instrument:

- 1 – Zeiss Coordinate Measuring Machine – UMM 500
- 2 – Interferometric Laser device
- 3 – Gage blocks for checking out the systematic errors

Traceability path (scale, interferometer, calibration std.):

- 1 – He-Ne Laser system calibrated at Inmetro's Optical Division – Stabilized Iodine He-Ne laser.
- 2 - Gage blocks calibrated by comparison in Inmetro's Dimensional Metrology Laboratory or by optical methodology in Inmetro's Optical Division.

Description of the measuring technique:

- The system

The gage was calibrated in a system composed by a coordinate measuring machine and an interferometric laser. The machine performs all movements and probings while the laser detects the table movements. Gage-blocks were used to determine the probing error as described below.

- Calibration of the system - Procedure.

It was chosen a line in the middle of the machine table, in x direction with a length of 400 mm, starting from approximately 25 mm from the beginning of the X range, coincident with the laser beam direction and also coincident with the step gage measurement axis height (considering gage supports).

The system was calibrated by taking gage blocks as reference, measured in the system so that the errors and associated uncertainties were determined for some points. Errors for all points were obtained by interpolation.

- Limitations.

The CMM is able to measure in the range of 0 mm to 500 mm. The system is calibrated to measure from approximately 25 mm from the beginning of the machine scale to 450 mm (last 25 mm is also not used), so lengths larger than 450 mm must be calibrated by parts (which was not the case).

- Step-gage calibration
 - Alignment:

The gage was supported in Bessel points, as outlined in the Protocol.

The alignment was obtained by using the two grooves at left and right of the gage. A line was generated passing through two points of symmetry of two lateral planes of the grooves in both left and right sides. The axis of measurements considered passes 30 mm below the upper surface of the gage. The differences in alignment did not exceed 5 μm for points in the end of the measurement range.

No other alignment methodology tried.

- Measurements

The measurements were performed so that the probe touched all the cylinder faces (all the gage steps) in each cycle.

The measurements were performed in several days to consider the influence of the reproducibility of the system as well as to detect any deviations due to positioning, fixing and gage form or defects. It was used the same 5 mm probe,

Five (05) cycles of measurements per calibration were performed.

Range of artefact temperature during measurements & description of temperature measurement method:

The temperature inside of the system chamber did not exceed (20 ± 0.5) °C. A liquid in glass thermometer (0.01 °C) was used to monitor the temperature near to the laser beam path. A barometer (0.001 mmHg) and a Thermo-higrometer (0.1 %) were also used to the environmental conditions so that the wave length could be corrected.

Two contact thermometers (0.001 °C) were used, whose sensors were placed over the upper surface of the gage approximately at 150 mm and 300 mm in the system range. The gage temperature was about (20 ± 0.1) °C in all cycles.

These conditions were not the best for calibration. Usually the calibrations are performed under better temperature conditions (in general, temperature does not exceed the range 20 ± 0.2 °C with a long term stability.

CENAM

Make and type of instrument

A mechanical guideline of a coordinate measuring machine SIP CMM 5L was used in addition with a laser interferometer and Cary (1-DIM) probe head. A Pt 100 calibrated thermometer was used also to measure the temperature of the artefact.

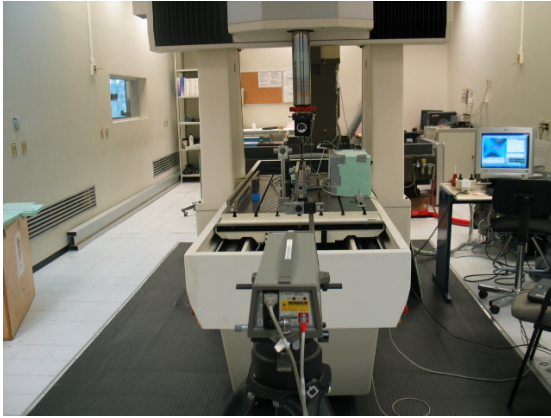
**Traceability path (scale, interferometer, calibration std.):**

Laser interferometer Agilent Technologies 5519A, Serial Number: US43061291

Certificate of Calibration: CNM-CC-740-120/2005 traceable to CENAM Primary Standard CNM-PNM-2

Probe head Cary 1-DIM, Serial Number: 6366

Calibrated in the moment versus Laser interferometer Agilent Technologies 5519A

Gauge block 20 mm Fowler, Serial Number 850469

Certificate of Calibration: CNM-CC-740-394/2006 using a TESA NPL Interferometer.

Pt 100 ALEMO 2290-8 calibrated by comparison in an isolated aluminium block versus Watlow Pt 100 Serial Number 434157 and thermometer ASA F300 Serial Number 8720001566, calibrated with Fixed points of water (B-16-945) and gallium (Ga 2002-1) according with ITS-90.

Description of the measuring technique:

The Step gauge was supported in Bessel points.

A coordinate measuring machine CMM SIP 5L was used to align the step gauge alignment surfaces around 0.001 mm.

A laser interferometer Agilent was aligned using a four quadrants photo detector around 0.005 mm with the mechanical guide of the CMM SIP 5L.

A probe head Cary 1-DIM is attached with the ram of the CMM

A carbide tungsten gauge block of 20 mm is aligned using the Cary 1-D around 0.0003 mm in vertical and horizontal axes.

All standards and instruments are in Abbe.

Measuring the central points of the gauge block, the effective diameter of the Cary 1-D was obtained.

The step gauge was measured go and back 5 times per cycle using the Cary 1-D and the Laser interferometer.

The measurement cycle was repeated to different environmental conditions and procedure alignments.

The environmental conditions and the step gauge temperatures were measured during the test to compensate the Laser and the step gauge expansion.

The back measurements were corrected with the effective diameter of the Cary 1-D.

Range of artefact temperature during measurements & description of temperature measurement method:

For every measurement cycle, 30 measurement temperatures (central point of the step gauge), the standard deviation of the temperature measurements was better than 0.012 °C

The temperatures for the different measurement cycles were inside of 20.14 °C and 20.02 °C

CEM

Make and type of instrument:

Custom-built length comparator CEM-TEK 1200 equipped with laser-interferometer in a two-beam plane optics pseudo-Abbe configuration and the following elements:

- Laser Head HP5517C ($\lambda = 633 \text{ nm}$)
- Relative refractometer (Tracker) HP 10717A
- Lever type inductive probe TESA GT31 (resol. 10 nm)
- Piezoelectric Actuator (resol. 5 nm)
- Standard Resistor WILKINS 100,000 Ω
- Resistance Bridge TINSLEY 5840F
- Temperature probes Pt 100
- Pressure meter RUSKA, serie 6200



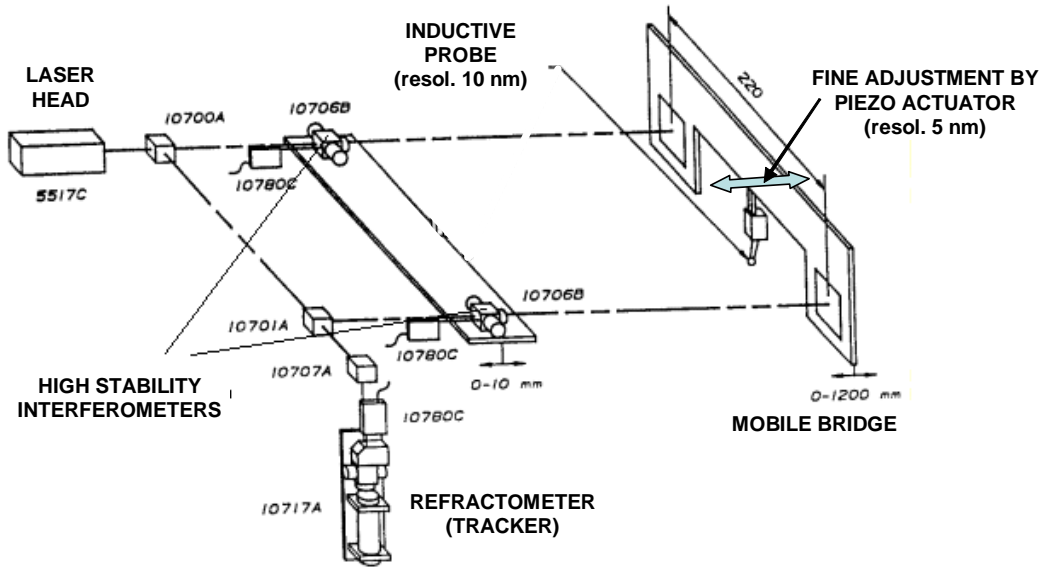

Traceability path (scale, interferometer, calibration std.):

Laser Head HP5517C calibrated against Iodine stabilized HeNe laser (national standard)

Method used for determination of refractive index of the air: Measuring of initial ambient conditions and applying of Edlen’s formulae. Then, continuous updating by using a tracking refractometer.

Description of the measuring technique:

Alignment with respect to outer frame with alignment check.

Step gauge supported at the Bessel points ($0.23 L$ from both ends) in order to minimize the sag caused by the own weight.

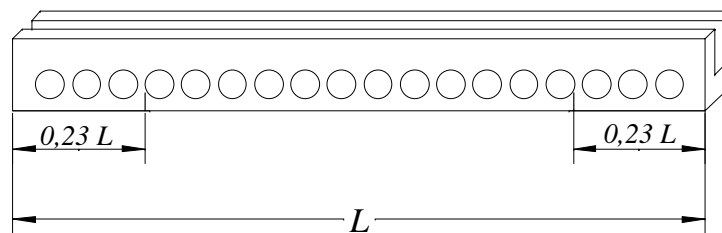

Measurement cycle programmed in teaching mode and subsequent automatic measurement without intervention of the operator.

Initial adjustment on a reference gauge block, 10 mm length, previously calibrated by absolute interferometry, in order to correct systematic effects on the indications on left and right faces, so avoiding the typical saw teeth response.

Measurement of all face distances to the first one (origin) by touching each face just in the line connecting the centres of the first and last one. Combination of inductive probing and piezoelectric actuation to get the finest resolution (5 nm). Plane optics move together with the probing system. Contact points contained within the plane formed by the laser beams (no Abbe error).

Distance obtained by counting interference fringes since the laser reset, when touching the first face, till the subsequent face. The distance is the average of both far and close (to the operator) laser beams, by symmetry of the comparator construction.

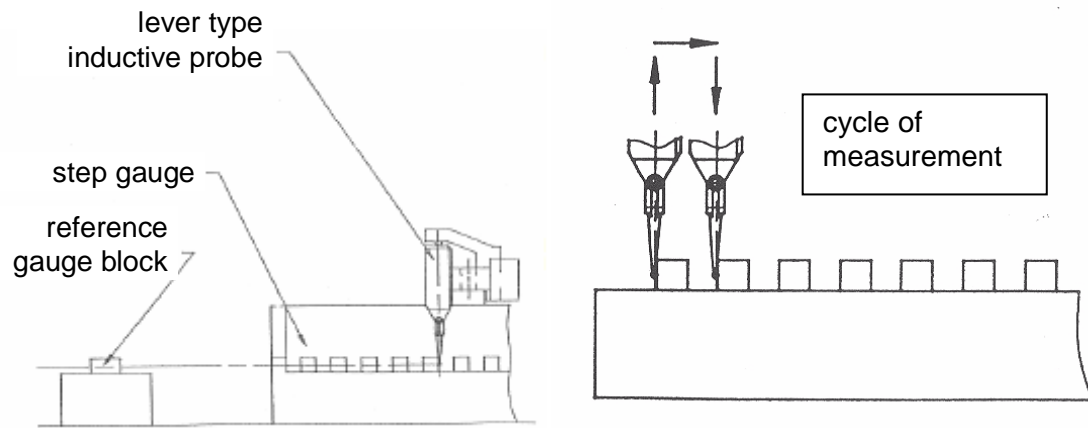

Range of artefact temperature during measurements & description of temperature measurement method:

20,05 °C to 20,19 °C. Temperature is measured using Pt 100 probes and comparison in real time of their resistance against a standard resistor, in a high accuracy Tinsley bridge.
