



## Simulation Tool for Designing off-Grid PV Applications for the Urban Environments

**Poulsen, Peter Behrendorff; Dam-Hansen, Carsten; Thorseth, Anders; Thorsteinsson, Sune; Lindén, Johannes; Petersen, Paul Michael; Mira Albert, Maria del Carmen; Knott, Arnold; Norby, Poul; Jensen, Allan Krogh**

*Total number of authors:*  
14

*Published in:*  
Proceedings of the 28th EU PVSEC

*Publication date:*  
2013

[Link back to DTU Orbit](#)

### *Citation (APA):*

Poulsen, P. B., Dam-Hansen, C., Thorseth, A., Thorsteinsson, S., Lindén, J., Petersen, P. M., Mira Albert, M. D. C., Knott, A., Norby, P., Jensen, A. K., Mogensen, I., Lyhne, M., Herbst, S., & Bay, A. (2013). Simulation Tool for Designing off-Grid PV Applications for the Urban Environments. In *Proceedings of the 28th EU PVSEC* (pp. 5CV.7.41)

---

### General rights

Copyright and moral rights for the publications made accessible in the public portal are retained by the authors and/or other copyright owners and it is a condition of accessing publications that users recognise and abide by the legal requirements associated with these rights.

- Users may download and print one copy of any publication from the public portal for the purpose of private study or research.
- You may not further distribute the material or use it for any profit-making activity or commercial gain
- You may freely distribute the URL identifying the publication in the public portal

If you believe that this document breaches copyright please contact us providing details, and we will remove access to the work immediately and investigate your claim.

# SIMULATION TOOL FOR DESIGNING OFF-GRID PV APPLICATIONS FOR THE URBAN ENVIRONMENTS

Peter Behrendorff Poulsen<sup>1</sup>, Carsten Dam-Hansen<sup>1</sup>, Anders Thorseth<sup>1</sup>, Sune Thorsteinsson<sup>1</sup>, Johannes Lindén<sup>1</sup>, Paul Michael Petersen<sup>1</sup>, Maria del Carmen Mira Albert<sup>2</sup>, Arnold Knott<sup>2</sup>, Poul Norby<sup>3</sup>, Allan Krogh Jensen<sup>4</sup>, Ib Mogensen<sup>5</sup>, Morten Lyhne<sup>6</sup>, Silla Herbst<sup>7</sup>, Anne Bay<sup>7</sup>

<sup>1</sup>Department of Photonics Engineering, Technical University of Denmark, Building 128, RISØ Campus, Frederiksborgvej 399, 4000 Roskilde, Denmark  
Tel. +45 4677 4572, ppou@fotonik.dtu.dk

<sup>2</sup>Department of Electrical Engineering, Technical University of Denmark, Lyngby, Denmark

<sup>3</sup>Department of Energy Conversion and Storage, Technical University of Denmark, Roskilde, Denmark

<sup>4</sup>AKJ Inventions, Vanløse, Denmark

<sup>5</sup>Out-sider, Copenhagen, Denmark

<sup>6</sup>Morten Lyhne Design, Græsted, Denmark

<sup>7</sup>Danish Lighting Center, Stenløse, Denmark

**ABSTRACT:** A barrier for exploiting use of standalone solar lighting for the urban environment seem to be lack of knowledge and lack of available tools for proper dimensioning. In this work, the first part of the development of powerful dimensioning tool is described and initial measurements are presented.

**Keywords:** PV urban lighting, Energy systems, standalone, LED lighting, dimensioning

## 1 INTRODUCTION

Digging down cables for small electrical applications in the urban environment is extremely expensive due to the high labor cost associated with it. Small stand-alone PV applications powered by 0.5-50 Wp can become very attractive since e.g. in Copenhagen in Denmark the cost of digging down cables in the city is about 1000 \$ pr. running meter so the cost savings on the cable digging can easily pay for the solar cells and electronics. The requirements to the products from the municipalities are high so if e.g. the products are for lighting purpose the reliability of the product meeting some specified amount of light is very important. The willingness to pay for such high-end stand-alone PV applications is though high but it is essential to be able to evaluate if the product will work in a given environment in both the development and dimension phase of the product and as a credible proof tool towards consumer/buyer/decision makers.

The barrier for exploiting this potential seems to be the lack of knowledge and tools for dimensioning and designing PV applications for the urban environments. The authors investigated the many PV dimensioning tools on the market and found none addressing exactly this issue and in the present project a design and simulation tool for small PV applications for the urban environment is under development.

## 2 PV-LED ENGINE MODEL

The block diagram below (Figure 1) shows the design of the simulation tool, which essentially is a computer model of a basic PV application, including PV panel, electronics, battery and power consumption.

Inputs to the model are data such as geographical position, orientation, local environment class and specifications about the PV module, control system, battery, etc. Also, a system data bank contributes with meteorological data and components data. Based on these parameters, the model calculates the performance of the PV application in a time resolved manner. The output of the model gives a detailed view on the energy flow in the

system so sizing becomes easy.

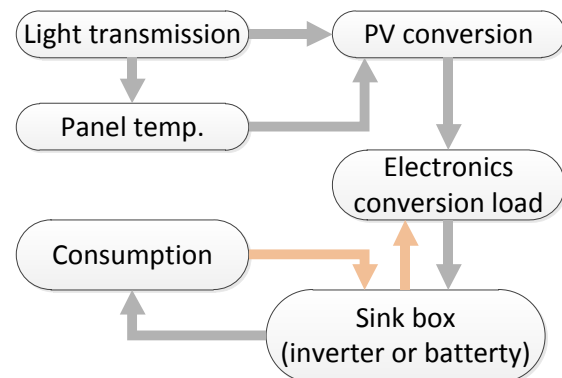

**Figure 1:** Block diagram of the PV simulation tool.

## 3 CHARACTERIZATION

To give a first implementation of the model, it is compared with the performance of a number of commercialized available high end park lamp products. These products are put out in the field in different environments and the performance of the PV-panel, electronics, battery and LEDs are logged. Few selected of these are also taken to lab where they have been disassembled and the sub-parts are afterwards characterized in the lab, to give input to the model.

### 3.1 Position Characterization

The conditions of the field positions are measured using a commercialized available hand-held shade measurement tool for solar site assessments (SunEye 210 Shade Tool, Solmetric). Equipped with fisheye lens camera, compass, GPS and shading identifying image processing software, this tool provides shading patterns, annual sun paths and monthly solar access, etc. Below (Figure 2) a solar access chart of one particularly site is shown.

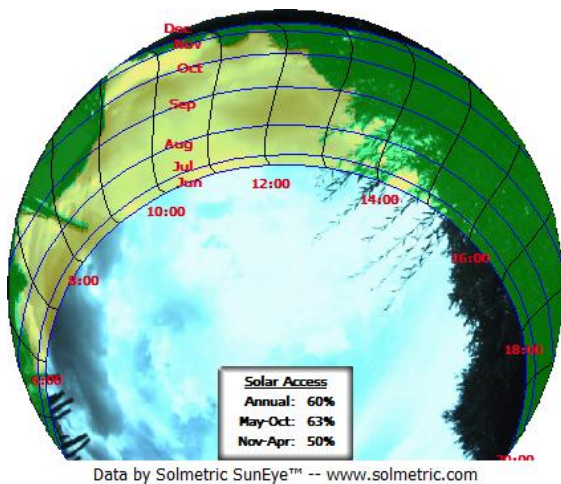

**Figure 2:** Solar access chart provided by the SunEye tool.

### 3.2 Parts Characterization

In order to accurately determine the performance of a particular park lamp product, the product is disassembled and each part is characterized in details so the performance can be estimated by interpolation of data points.

A typical park light system consists of a small PV module in the range 0.5-5 Wp, an electronic controller managing the charging of the battery and managing the power flow to the LED, a battery and a LED.

Each of these 4 components is characterized in dedicated labs under different load conditions.

For the PV part IV-curves is recorded under 10-15 different illuminations, all AM 1.5 varying from .05 Sun till 1.2 Sun, and the full IV-curves is put into the simulation since it turns out that far from all charge controllers have maximum power point trackers. The IV curves are plotted in Figure 3 with the current on the left and the sun intensity on the right, which should be read at the left axis intersection – i.e. at the short circuit current.

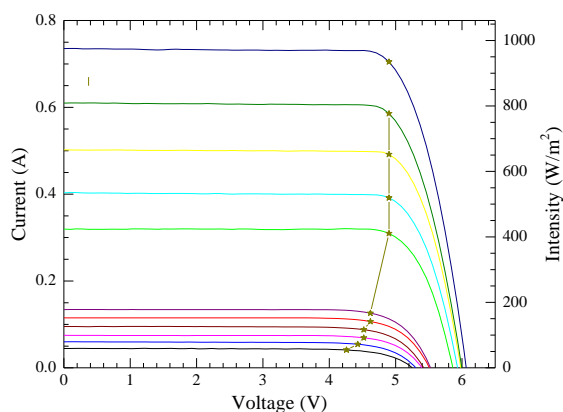

**Figure 3:** IV-curves.

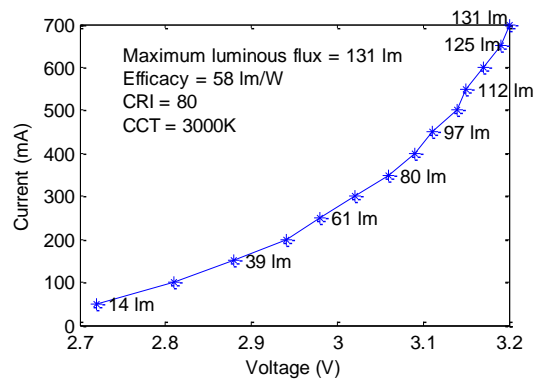
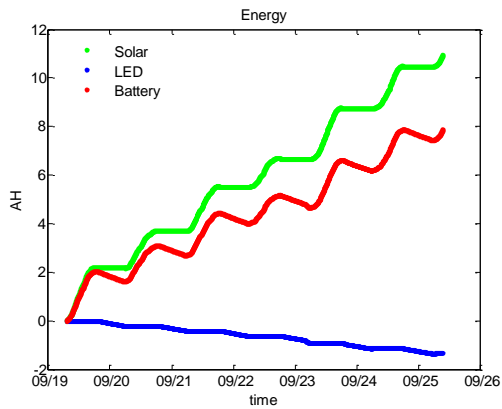

**Figure 4:** Example of concluded results from a characterization measurement of a LED light source in one of the purchased park lamps.

Included in the work of validating the model is characterizing the different components of the park lamps purchased, as briefly mentioned above. Figure 4 shows some concluded results of one of the park lamps LED light source, after being measured in the lab. Besides the quality of the light, such as Correlated Color Temperature (CCT) and Color Rendering Index (CRI), parameters related to the efficiency of the light source are being measured, such as total luminous flux, efficacy and total radiant flux. All these parameters are possible inputs in the model, which will make it possible to investigate the potential of improvements associated with different available products.

### 3.3 Field measurement

A few Park lights were put onto to our test side, equipped with data logging in order to determine the energy flow in the system with reference to a pyranometer (Kipp & Zonen SMP3-I) installed nearby. Since typically the PV is voltage controlled, measuring the current in the PV loop requires special attention. Measuring the current by measuring a voltage drop over a resistor, gives an additional voltage drop in the loop and perturbs the control of the PV. Choosing a resistive current measurement, the resistor should be chosen to be as small as possible, however large enough to provide good resolution to the data logger. Therefore a current sensor that senses without introducing a voltage drop in the loop is preferred; however these are expensive for the relevant current range. Another alternative is to improve the resolution by amplifying the voltage over the measurement resistor. For the data logging in this system the current is measured via a very small resistor limiting the resolution on the current measurements. The cumulative energy flow for few selected days is plotted in Fig 5, with the zero being arbitrary. The data is recorded close to fall equinox and therefore it is to be expected that there is energy enough for the night to light the LED, as can be seen as a straight blue line. For this product the size of the battery around 6 AH, however the charge controller seems to continue charging even though the battery is full, and thereby degrading the battery.



**Figure 5:** Energy gain for a few days in septemeber. The starting point is arbitrary chosen and the battery was not empty.

#### 4 FUTURE WORK

The next step forward in this project is to collect measurements on the electronic controller and the batteries that will enable to simulate the behavior of the chosen park light and later on validate the model by comparing the simulated behavior with the actual measured behavior.

The resolution on the current measurement on the field testing will be improved and generic models that describe system behavior via datasheet information will be developed.

Parallel to the modeling work prototypes of park lights will be demonstrated where both dedicated power electronics, PV and LEDs will be chosen and combined with intelligent dimming control. The total system electronic efficiency is expected to be above 80 %.

#### 5 CONCLUSION

We have demonstrated important building blocks to facilitate a powerful dimensioning tool and partial validated it to existing product. Measurement on existing products shows a lot can be done by upgrading the performance of the electronics.

#### 6 AKNOWLEDGEMENTS

The project is funded by the Danish Energy Technology Development and Demonstration Programme, project number 64011-0323, "The PV LED Engine - new generation of intelligent solar powered LED lighting".