



Local cooling of the human body using ventilated mattress in hospitals

Bivolarova, Mariya Petrova; Melikov, Arsen Krikor; Kokora, Monika ; Bolashikov, Zhecho Dimitrov

Published in:

Proceedings of ROOMVENT 2014, 13th SCANVAC International Conference on Air Distribution in Rooms

Publication date:

2014

[Link back to DTU Orbit](#)

Citation (APA):

Bivolarova, M. P., Melikov, A. K., Kokora, M., & Bolashikov, Z. D. (2014). Local cooling of the human body using ventilated mattress in hospitals. In *Proceedings of ROOMVENT 2014, 13th SCANVAC International Conference on Air Distribution in Rooms* (pp. 279-286)

General rights

Copyright and moral rights for the publications made accessible in the public portal are retained by the authors and/or other copyright owners and it is a condition of accessing publications that users recognise and abide by the legal requirements associated with these rights.

- Users may download and print one copy of any publication from the public portal for the purpose of private study or research.
- You may not further distribute the material or use it for any profit-making activity or commercial gain
- You may freely distribute the URL identifying the publication in the public portal

If you believe that this document breaches copyright please contact us providing details, and we will remove access to the work immediately and investigate your claim.

LOCAL COOLING OF THE HUMAN BODY USING VENTILATED MATTRESS IN HOSPITALS

Mariya Bivolarova¹, Arsen Melikov¹, Monika Kokora^{1,2} and Zhecho Bolashikov¹

¹International Centre for Indoor Environment and Energy, Department of Civil Engineering, Technical University of Denmark, Kgs. Lyngby, Denmark.

²Department of Environmental Engineering, Warsaw University of Technology, Warsaw, Poland.

Abstract

A series of experiments were conducted in order to examine the cooling of the human body in bed equipped with a ventilated mattress (VM). The experiments were performed in a climate chamber (4.65 m width x 5.3 m length x 2.6 m height) which was air-conditioned by mixing ventilation system. A thermal manikin lying in the bed with the VM was used to simulate a person. The surface temperature and heat loss of the thermal manikin were controlled to correspond to those of an average person in a state of thermal comfort. The local cooling effect of the VM was studied at room air temperatures of 23, 26 and 30 °C. The performance of the VM was tested when VM was operating at different air flow rates (1.5, 3, 4.5 and 6 L/s). The impact of body covering on the cooling effect from the VM was also studied. The performance of the cooling method was evaluated based on comparison of the segmental and whole body equivalent temperature (t_{eq}) with those determined at the reference temperature of 23 °C or when at the same room temperature with VM not in operation. The obtained results reveal that the body segments in contact with the VM were cooled, especially the back side and the back. The cooling effect increased with the increase of the airflow rate through the VM. These results suggest that in warm environment the VM may improve thermal comfort of people lying in bed. The use of the VM may lead to energy saving by operating the background ventilation system at elevated set point for the room temperature or by use of natural ventilation. However the non-uniform body cooling may cause local thermal discomfort. This needs to be further studied in human subject experiments.

Keywords: Local cooling, Ventilated mattress, Bed thermal comfort, Hospital environment

1 Introduction

On average people sleep eight hours every day. The quality of sleep affects peoples' work performance and well-being. In some premises such as hospitals, elderly homes, etc., some occupants spend most of their time lying in bed. The indoor environment, including their thermal comfort affects their health conditions. High room temperatures can result in reduced quality of sleep.

Large amount of energy is used in buildings. Substantial part of this energy is used for generating healthy and comfortable environment indoors. Energy saving policies has been introduced in many countries. In warm climates and seasons when outdoor temperature is high air conditioning is used to keep the room temperature within the comfortable range specified in the standards (EN 15251 2007, ASHRAE 55 2013). This however is not energy efficient because the air in the entire room volume, most of which is not occupied, is conditioned. One energy saving strategy suggested in the standards (EN 15251 2007, ASHRAE 55 2013) is to keep operative temperature indoors high and to provide occupants with thermal comfort by air movement at elevated velocity. However as reported by Melikov et al. (2012) in warm environments elevated velocity is not efficient method to provide

people lying in bed with thermal comfort. Generating comfortable bed micro-environment may save energy.

Melikov et al. (2012) reported on improved bed micro-environment by water cooled mattress and bed ventilation simulated by a flexible pipe providing air below the quilt from the side of feet. In this paper cooling provided by a ventilated mattress with air flow through the mattress was studied.

2 Method

2.1 Experimental set-up

Full-scale experiments were performed in a climate chamber with dimensions: 4.65 m (width), 5.3 m (length), and 2.6 m (height). Overhead mixing air distribution (MV) was used to supply 100% outdoor air to the chamber through a three-way square diffuser mounted in the middle of the ceiling. No recirculation was used during the experiments. The air was exhausted through two perforated square diffusers located symmetrically on the ceiling.

A thermal manikin was used to simulate lying patients in a bed. The bed had dimensions 0.9 m x 2.0 m x 0.8 m (W x L x H) and had a mattress with thickness of 0.06 m. The mattress was covered with a thin cotton sheet. The thermal manikin has the physics of an average Scandinavian female with a height of 1.68 m and size 38. The manikin consists of 23 body parts. Each body segment was individually controlled to maintain surface temperature equal to the skin temperature of an average person in a state of thermal comfort. The manikin was lying in the bed on its back. The manikin was dressed in a short-sleeve hospital pyjama (clothing isolation was 0.60 Clo). The layout of the test chamber is shown in Figures 1 and 2.

A ventilated mattress (VM) was placed on top of the regular mattress (Figure 1). Air was drawn through the ventilated mattress from an exhaust opening at the feet area of the manikin. The dimensions of the exhaust opening were 0.8 x 0.16 m². The exhaust opening was covered with textile mesh with free area ratio of approximately 90%. There was a mesh inside the ventilated mattress which provided support and allowed the exhaust air to move through the whole mattress. For the purpose of the experiments the VM was connected to a separate exhaust system having an axial fan outside of the chamber via a flexible duct (Ø 80 mm). The exhaust flow rate of the VM was regulated by changing the frequency of the fan and by adjusting the damper installed in the duct connected to the VM. In order to adjust the desired airflow rate exhausted from the VM two air flow sensors were installed in the duct.

2.2 Experimental conditions

The ability of the ventilated mattress to cool the thermal manikin lying in the bed was examined at numerous combinations of the flow rate through the mattress (1.5, 3, 6 and 10 L/s), room air temperature (23, 26 and 29 °C) and different body covering (body covered with sheet (0.32 clo), with light quilt (3.2 clo) and without body covering). During the experiments the background room ventilation was set at 1.5 air changes per hour. The relative humidity in the chamber was not controlled; it was measured to be in the range of 25 – 40%.

2.3 Data analyses and presentation

Heat loss from the segments and whole body of the thermal manikin as well as their surface temperature was measured. The collected data were used to calculate the equivalent temperature, t_{eq} , for the segments and the whole body. The equivalent temperature is defined as “The uniform temperature of the imaginary enclosure with air velocity equal to zero in which a person will exchange the same dry heat by radiation and convection as in the actual non-uniform environment” (SAE 1993, ISO 2004). The segmental and whole body cooling effect of the ventilated mattress was assessed by the change in the equivalent temperature determined for the studied condition compared to the equivalent temperature, $t_{eq,ref}$, determined at a given reference condition. The calculations were made in two ways as presented in equations 1 and 2:

$$\Delta t_{eq1} = t_{eq,i} - t_{eqi,ref1} \quad (1)$$

$$\Delta t_{eq2} = t_{eq,i} - t_{eq,ref23} \quad (2)$$

Where $t_{eq,i}$ and $t_{eqi,ref1}$ (°C) is the segmental or whole body equivalent temperature determined for the same room air temperature respectively with and without ventilated mattress in operation; $t_{eqi,ref23}$ (°C) is the segmental or whole body equivalent temperature determined without ventilated mattress at 23 °C. Δt_{eq1} is a measure for the cooling performance of the ventilated mattress while Δt_{eq2} may be used to assess the thermal comfort provided with the ventilated mattress at elevated temperature compared to comfortable temperature of 23 °C without additional cooling of the body. Negative values of Δt_{eq1} mean that the mattress increases the heat loss from the body, i.e. provides cooling. Negative values of Δt_{eq23} mean that people will report cooler thermal sensation compared to that at 23 °C without mattress and positive values will mean warmer thermal sensation.

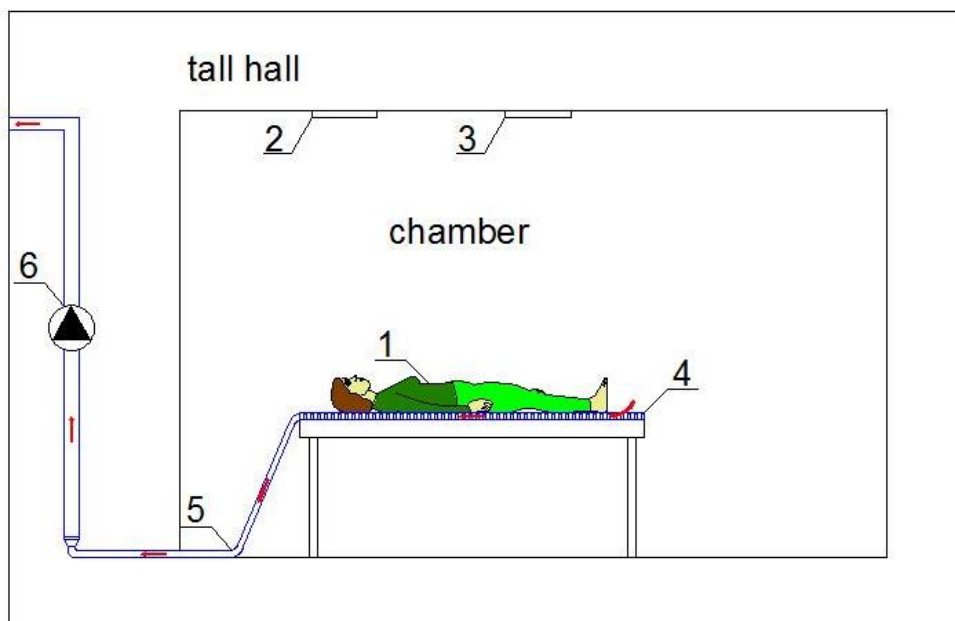

Figure 1. Side view sketch of the experimental set-up in the chamber: 1 –lying patient, 2 – exhaust diffusers, 3 – supply diffuser, 4 – the ventilated mattress, 5 – exhaust duct from the ventilated mattress, 6 – axial fan.

3 Results and Discussion

Figure 2 shows the change of the equivalent temperature, Δt_{eq1} , as a result of the use of the mattress. The results obtained at 23, 26 and 29 °C and flow rate of 1.5, 3 and 6 L/s (also 10 L/s at 29 °C) through the mattress when the manikin was covered with a sheet are shown. As expected the results reveal that the body segments in contact with the ventilated mattress were cooled. The head region (crown, left and right face and the back of neck) were almost not affected by the cooling provided with the VM. The results show that the cooling from the mattress decreased with the increase of the room temperature. Increase of the ventilation flow through the mattress increased the heat loss from most of the body segments. Back side (lower back) and the back were the most cooled body segments.

The importance of manikin's body covering on the cooling provided by the VM was studied as well. Results obtained with the VM at different flow rate and room air temperature was compared when the manikin's body was not covered, when it was covered with sheet and when it was covered with light quilt. The use of body covering increased the cooling from the VM at 23, 26 and 29 °C. The

increase of the cooling effect was observed for the whole body and all body segments except the head region that was not covered. The body cooling increased when the thermal insulation of the covering increased (Figure 3, sheet and light quilt). Figure 4 compares the results obtained at 23 °C.

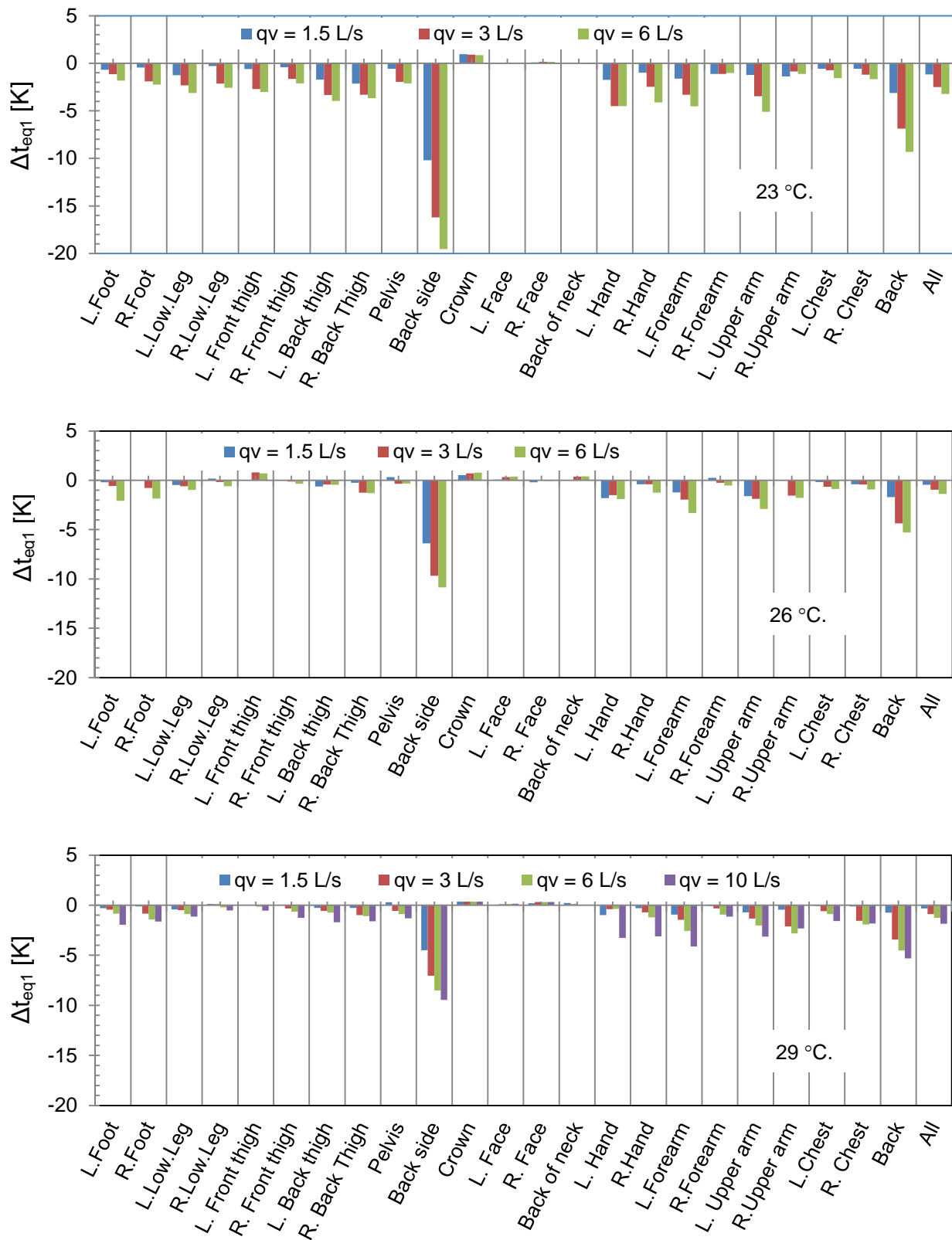

Figure 2. Change in the equivalent temperature, Δt_{eq1} , for manikin's segments and whole body at different flow rates and room air temperature with VM in operation. Manikin covered with sheet.

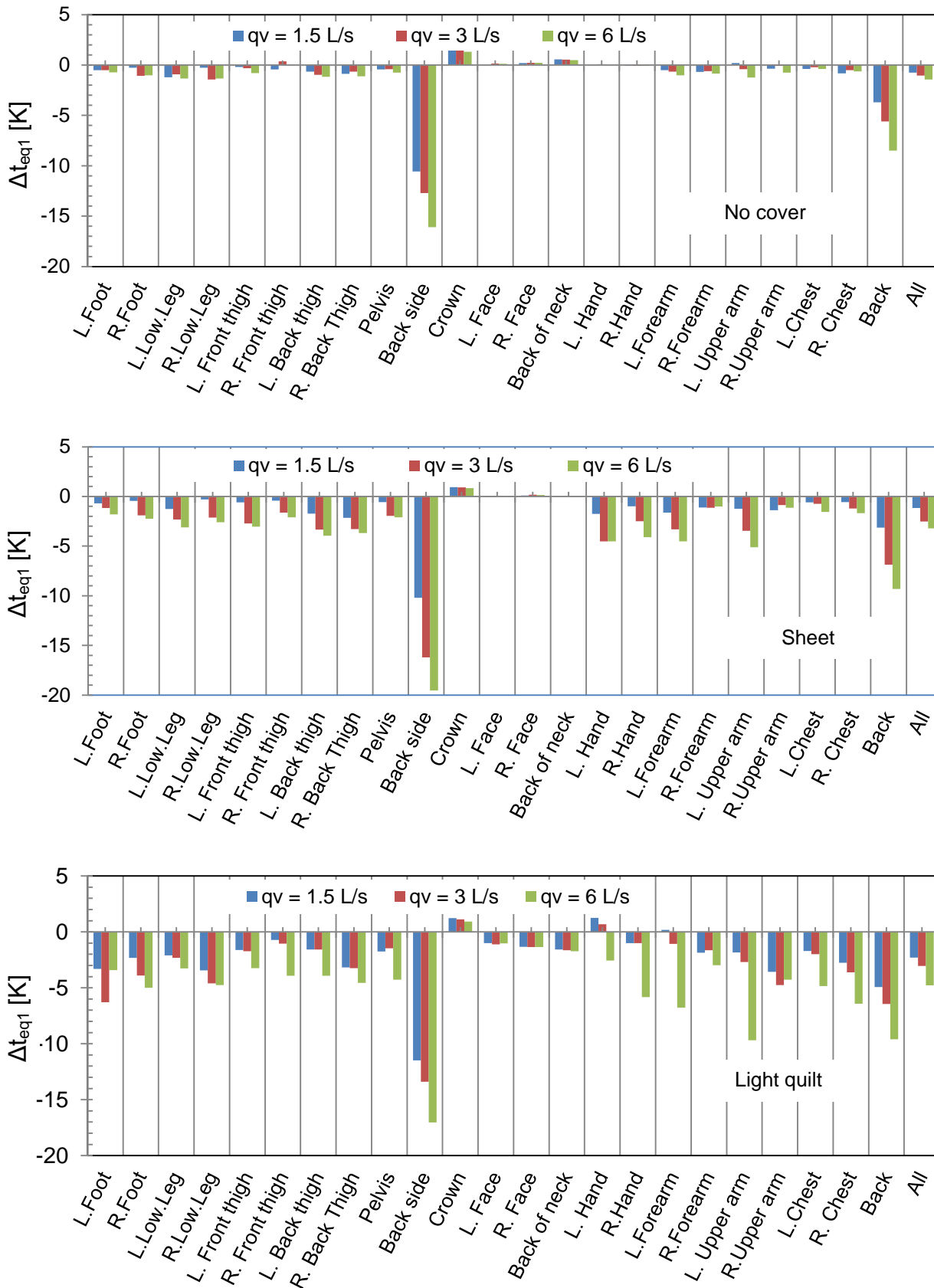

Figure 3. Change in the equivalent temperature, Δt_{eq1} , for manikin's segments and whole body at different flow rates and body covering with VM in operation. Room air temperature at 23 °C.

The ability of the VM to improve a person’s thermal comfort at elevated room temperature to the thermal comfort level at comfortable temperature of 23 °C was assessed with the change in the equivalent temperature Δt_{eq2} . Some of the obtained results are shown in Figure 4. The results in the figures show that the increase of the room temperature will make the person lying in bed with the VM in operation to feel warmer than at 23 °C. This thermal sensation will be felt for the body as a whole and for all body segments except the back side and the back. The results suggest that at these two body parts, especially at the back side, a person in a bed with VM will feel locally cooler than at 23 °C. The analyses of the results reveal that at 26 °C and 29 °C a person lying in a bed with VM will feel cooler when his/her body is covered with sheet compared to when the body is not covered.

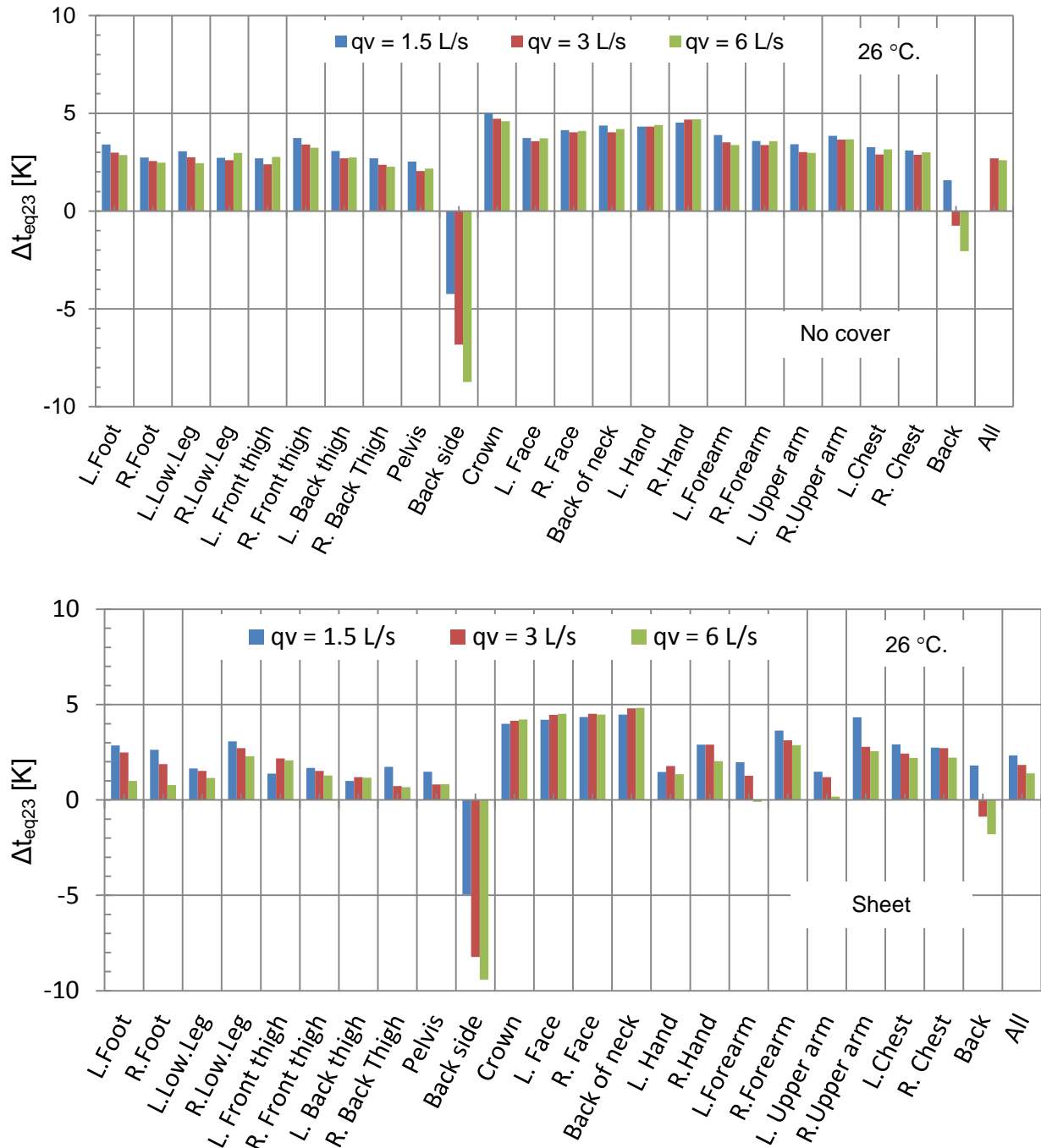

Figure 4. Change in the equivalent temperature, Δt_{eq2} , at room air temperature of 26 °C compared to at room air temperature of 23 °C. VM in operation. Results when the body is covered with sheet and not covered are shown.

4 Discussion

The results of the present study reveal that the ventilated mattress provides body cooling. Only the head region isolated from the mattress with pillow was not cooled. The cooling increased with the increase of the airflow rate through the mattress and decreased with increase of the room temperature. All body segments in contact with the mattress were cooled. Covering the manikin's body with sheet or light quilt increased the cooling of the manikin's body segments when the VM was in operation. The back side and the back of the thermal manikin were cooled intensively since most of their surface area was in contact with the mattress. For the remaining cooled body segments only relatively small part of their surface area was in contact with the VM and cooling was measured mainly when manikin's body was covered, e.g. with sheet. The cooling was equal to that obtained by decrease of the room air temperature by several degrees, between 4 and 20 K for the lower back, 2-10 K for the back and up to 4 K for the remaining body segments (for most of them less than 1K). The cooling for the whole body of the manikin was equal to that achieved by decrease of the room temperature by up to 3 K.

The results suggest that the use of the VM at elevated room temperature will decrease the local thermal sensation at the back side and the back (not measured at 29 °C) compared to the thermal sensation at 23 °C. For the remaining body parts and for the whole body the thermal sensation will be warmer than at 23 °C. The increase of the airflow rate through the VM and covering of the body with sheet will improve the thermal sensation when the mattress is in operation and will move it toward the thermal sensation reported at 23 °C. However the large differences in local thermal sensation as a result of the non-uniform body cooling may cause discomfort. This needs to be studied in human subject experiments.

The use of the VM has potential for energy saving in warm climates and during seasons when outdoor temperature is high and cooling with mechanical ventilation is used for improving the thermal environment in rooms. In this case room temperature can be kept relatively high, i.e. the room will be less cooled, and local body cooling will be provided with the ventilated mattress in order to obtain comfortable bed micro-environment. However as already suggested this strategy needs to be verified in human subject experiments because of the non-uniform body cooling which may cause discomfort.

Hospitals, hotels, elderly homes, bedrooms, etc. are some of the premises where the VM can be used. The VM can be used for to exhaust/clean the air polluted with body bioeffluents and squama as reported by Bivolarova et al. (2014). This will lead to decrease of the needed room ventilation leading to energy saving. Thus use of the VM may improve thermal comfort of people lying in bed, increase room air quality and save energy.

5 Conclusions

The ventilated mattress provided cooling to the thermal manikin's body segments it was in contact with. The cooling increased with the increase of the airflow rate through the mattress, decreased with increase of the room temperature and increased when manikin's body was covered with sheet or light quilt. The back side and the back of the thermal manikin were cooled intensively since most of their surface area was in contact with the mattress. The remaining body segments in contact with the VM were cooled when the manikin's body was covered. The cooling effect for the whole body of the manikin was smaller than that for the segments.

Large differences in the local thermal sensation may be expected when the VM is used. Human subject experiments are needed to identify the impact of the non-uniformity in the local body cooling on the overall thermal sensation of people lying in bed and acceptability of the generated bed micro-environment.

The use of the mattress has potential for energy saving. This needs to be studied.

6 Acknowledgement

This research was funded by European research project FP7-People-2012-ITN-Drant Agreement number 315760.

7 Reference

1. EN 15251 (2007) Indoor environmental input parameters for design and assessment of energy performance of buildings addressing indoor air quality, thermal environment, lighting and acoustics, European Committee for Standardization, Brussels.
2. ASHRAE. Standard 55: Thermal environmental conditions for human occupancy. Atlanta. GA: 2013.
3. Melikov, A.K., Li, Y., Georgiev, E., Wu, J., 2012, Bed Micro-environment in Hospital Patient Rooms with Natural or Mechanical Ventilation, Proceedings of Healthy Buildings 2012, 8-12 July 2012, Brisbane, session 10G, paper 10G.6.
4. ISO. 2004. ISO 14505-2, Ergonomics of the Thermal Environment—Evaluation of Thermal Environment in Vehicles—Part 2: Determination of Equivalent Temperature. Geneva: International Organization for Standardization.
5. Bivolarova, M.P., Melikov, A.K., Kokora1, M., Mizutani, C. and Bolashikov, Z.D., Novel bed integrated ventilation method for hospital patient rooms. Proceedings of Roomvent 2014, Sao Paulo, Brasil, Oct. 20-22 2014, paper 169.