



Measuring Grain Resolved Stresses during in situ Plastic Deformation using 3DXRD

Oddershede, Jette

Publication date:
2012

Document Version
Peer reviewed version

[Link back to DTU Orbit](#)

Citation (APA):
Oddershede, J. (2012). *Measuring Grain Resolved Stresses during in situ Plastic Deformation using 3DXRD*. Abstract from International Symposium on Plasticity 2012 and Its Current Applications, San Juan, Puerto Rico.

General rights

Copyright and moral rights for the publications made accessible in the public portal are retained by the authors and/or other copyright owners and it is a condition of accessing publications that users recognise and abide by the legal requirements associated with these rights.

- Users may download and print one copy of any publication from the public portal for the purpose of private study or research.
- You may not further distribute the material or use it for any profit-making activity or commercial gain
- You may freely distribute the URL identifying the publication in the public portal

If you believe that this document breaches copyright please contact us providing details, and we will remove access to the work immediately and investigate your claim.

MEASURING GRAIN RESOLVED STRESSES DURING IN SITU PLASTIC DEFORMATION USING 3DXRD

Jette Oddershede*

***Center for Fundamental Research: Metal Structures in Four Dimensions,
Materials Research Division, Risø DTU, Frederiksborgvej 399, DK-4000 Roskilde,
jeto@risoe.dtu.dk**

ABSTRACT Three-Dimensional X-Ray Diffraction (3DXRD) allows the center-of-mass positions, orientations, sizes, phases, elastic strain and thus type-II stress tensors of individual grains within the bulk of a polycrystalline material to be measured during *in situ* deformation. The scientific implications of this are illustrated by two examples, one on 1.5% deformed Cu to demonstrate the benefits for polycrystal plasticity modeling, and the other on a notched Mg sample to show the advantages for local stress mapping in coarse-grained materials.

INTRODUCTION: Polycrystal plasticity models are widely used to predict both the evolution of deformation textures and the resulting mechanical properties. The verification and improvement of models have been impeded by the lack of experimental data on both the plastic deformation (plastic strain as well as the associated lattice rotation) and the elastic strains on the grain scale. Obviously 3DXRD is a powerful tool in this connection, as demonstrated by the study of about 1000 randomly oriented grains embedded in a polycrystalline copper sample [Oddershede *et al.* 2011].

Three-dimensional stress mapping based on scanning neutrons or hard X-ray beams across the sample and analysing the resulting powder patterns has become a routine tool. However, for studying local phenomena such as the stress field and plastic deformation zone at an edge or around a crack tip, the number of grains in the volume of interest may not be sufficient for powder diffraction methods to apply. By using each grain as an independent probe a much-improved map — in terms of spatial resolution — can be obtained. As an example of this type of application, the stress field and associated plastic deformation zone around a notch in a coarse-grained Mg AZ31 sample was measured under tensile load.

PROCEDURES, RESULTS AND DISCUSSION: With the standard setup and procedures, as also used for the present examples, it has been shown that for each grain in an undeformed material the position can be determined with an accuracy of 10 μm , the orientation to 0.05°, the size with a relative error of 20 %, and the axial, transversal and shear components of the elastic strain tensor to 1, 2 and 1.5×10^{-4} , respectively [Oddershede *et al.* 2010].

Plastic Deformed Copper: The grain resolved positions, sizes, orientations and elastic strains of about 1000 randomly oriented grains embedded in a polycrystalline copper sample were measured in the undeformed state and at a plastic strain of 1.5 % while the sample was

under tensile load. Fig. 1 shows the grains in the mapped section of the cylindrical sample (1 mm diameter) colour coded according to the elastic strain along the tensile z -axis in the deformed state. The axial strains were found to exhibit a grain orientation dependence with grains within 20° of $\langle 100 \rangle$ carrying a 50 % larger strain, see Fig. 2 region 4. In Fig. 2 the largest lattice rotations in the deformed Cu sample are shown in black (towards circular symbol, please note that the indicated magnitudes of the rotations are three times larger than the measured ones for clarity). It can be seen that the rotation direction depends on the grain orientation, and that the stereographic triangle can be split into four regions with different rotation behavior. This is in perfect agreement with previous findings for about 100 grains in a 6 % tensile deformed aluminium sample [Winther *et al.* 2004]. Examining the strain distributions for different texture components one finds that the widths do not change upon plastic loading. However, the grain resolved data show a significant broadening of the distribution evaluated for small subsets of initially elastically similar grains independent of grain orientation, a broadening which could be attributed to grain–grain interactions.

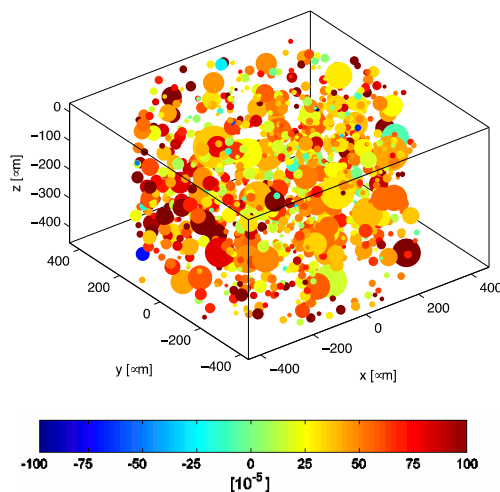

Fig. 1 Cu at 1.5% deformation, axial strain colour bar also applies to Fig. 2.

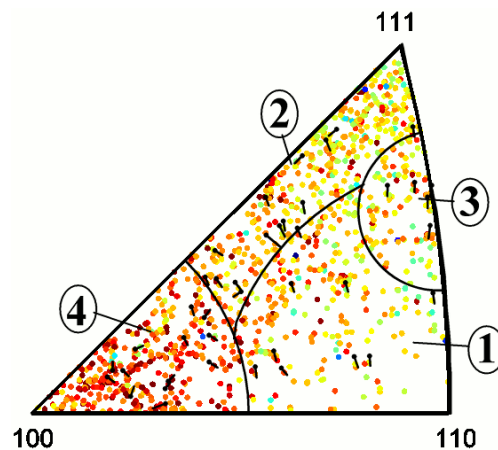

Fig. 2 Stereographic triangle showing the orientation dependence of the axial strain and lattice rotations in 1.5% deformed Cu.

Notched Magnesium: In a hot extruded Mg AZ31 specimen with a cross section of $0.8 \times 4 \text{ mm}^2$ and an average grain size of $30 \text{ }\mu\text{m}$, a 0.2 mm notch was made with laser beam cutting (Fig. 3). A tensile load was applied to open the notch and eventually grow a crack, and the 3DXRD technique was used to map a volume containing 2000+ grains in front of the notch. Fig. 4 shows the initial outline of the notch and the experimental contour of the axial stress field at an applied load of 170 MPa , i.e. just before macroscopic yielding (180 MPa). The experiment showed a tensile stress concentration gradually building up in front of the notch as the load was increased, c.f. Fig. 4. However, at the highest applied load (205 MPa) a stress relaxation was observed in front of the notch. The tomographic data collected at each load step showed a movement of the crack front into the sample (towards $-x$) of around $100 \text{ }\mu\text{m}$ at 205 MPa . Based on this the observed stress relaxation is attributed to the initiation and propagation of a crack. A tensile stress concentration was likewise observed in the in-plane

stress component (along y) near the notch tip, indicating that a transition from an overall plane stress case away from the notch to an essentially plane strain case near the notch tip takes place. In addition intra-granular deformation gradients near the notch are evident from the experimental data, as larger peak broadening is observed for the grains in this region. The white contour levels shown in Fig. 4 originate from a three-dimensional finite element based continuum model.

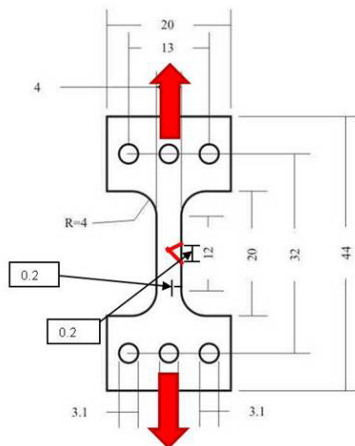

Fig. 3 Sketch of notched Mg sample. All distances are in mm.

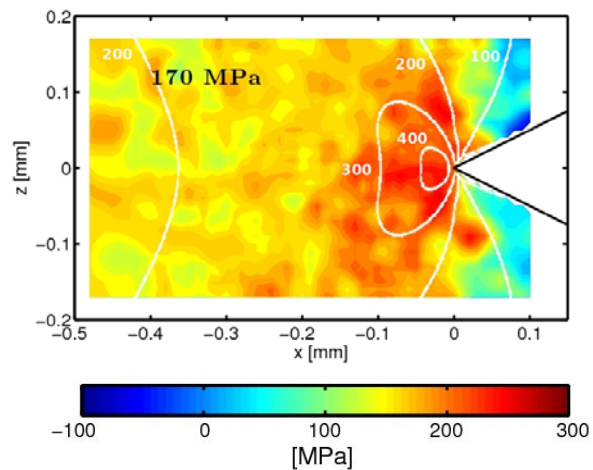

Fig. 4 Axial stress field at notch tip in Mg at 170 MPa tensile load along z .

CONCLUSIONS: The here presented technique and experimental data represent a major progress for the evaluation and development of elasto-plastic polycrystalline models, especially at the grain scale, but also both at smaller and larger scales.

ACKNOWLEDGEMENTS: The author gratefully acknowledges funding from the German Bundesministerium für Bildung und Forschung and Danscatt, a centre funded by the Danish Natural Science Research Council. ESRF and APS are acknowledged for granting beamtime.

REFERENCES:

- Oddershede, J., Schmidt, S., Poulsen, H.F., Sørensen, H.O., Wright, J., and Reimers, W. 2010, "Determining grain resolved stresses in polycrystalline materials using three-dimensional X-ray diffraction", *J. Appl. Crystall.*, **43**, 539.
- Oddershede, J., Schmidt, S., Poulsen, H.F., Margulies, L., Wright, J., Moscicki, M., Reimers, W., and Winther, G. 2011, "Grain-resolved elastic strains in deformed copper measured by three-dimensional X-ray diffraction", *Mater. Charact.*, **62**, 651.
- Winther, G., Margulies, L., Schmidt, S., and Poulsen, H.F. 2004, "Lattice rotations of individual bulk grains Part II: correlation with initial orientation and model comparison", *Acta Mater.*, **52**, 2863.