



Nighttime radiative cooling potential of unglazed and PV/T solar collectors: parametric and experimental analyses

Pean, Thibault Quentin; Gennari, Luca; Olesen, Bjarne W.; Kazanci, Ongun Berk

Published in:

Proceedings of the 8th Mediterranean Congress of Heating, Ventilation and Air-Conditioning (CLIMAMED 2015)

Publication date:

2015

Document Version

Peer reviewed version

[Link back to DTU Orbit](#)

Citation (APA):

Pea, T. Q., Gennari, L., Olesen, B. W., & Kazanci, O. B. (2015). Nighttime radiative cooling potential of unglazed and PV/T solar collectors: parametric and experimental analyses. In *Proceedings of the 8th Mediterranean Congress of Heating, Ventilation and Air-Conditioning (CLIMAMED 2015)*

General rights

Copyright and moral rights for the publications made accessible in the public portal are retained by the authors and/or other copyright owners and it is a condition of accessing publications that users recognise and abide by the legal requirements associated with these rights.

- Users may download and print one copy of any publication from the public portal for the purpose of private study or research.
- You may not further distribute the material or use it for any profit-making activity or commercial gain
- You may freely distribute the URL identifying the publication in the public portal

If you believe that this document breaches copyright please contact us providing details, and we will remove access to the work immediately and investigate your claim.

ID 40 - Nighttime radiative cooling potential of unglazed and PV/T solar collectors: parametric and experimental analyses

Thibault Péan, Luca Gennari, Bjarne W. Olesen and Ongun B. Kazanci

International Centre for Indoor Environment and Energy, Department of Civil Engineering, Technical University of Denmark, Nils Koppels Allé, Building 402, 2800 Kgs. Lyngby, Denmark.

Corresponding email: thipe@byg.dtu.dk

SUMMARY

Nighttime radiative cooling technology has been studied both by means of simulations and experiments, to evaluate its potential and to validate the existing theoretical models used to describe it. Photovoltaic/thermal panels (PV/T) and unglazed solar collectors have been chosen as case studies. An experimental setup has been constructed and tested during summer of 2014, at the Technical University of Denmark. The cooling performance (heat loss) has been measured simultaneously for both types of panels, installed side-by-side. The experimental results have been compared with the results from a commercial building simulation software and from theoretical calculations. All three methods showed good consistency in the cooling output.

The cooling power ranged between 20 to 75 W/m² without a noticeable difference between the PV/Ts and the unglazed collectors, the outcome depending mainly on the sky clearness. The obtained values showed a good agreement with the ones found in the literature about solar panels or other kinds of heat sinks used for radiative cooling applications.

The panels provided a cooling performance per night ranging between 0.2 and 0.9 kWh/m² of panel. The COP values (defined as the ratio between the obtained cooling and the energy used by the circulation pump) reached very high values, ranging from 19 to 59, which highlights the potential of this technology for energy savings for cooling purposes. Possible applications include cooling production for non-residential buildings such as offices under the Scandinavian climate, and, in addition, for residential buildings under Southern climates.

Keywords: Nighttime radiative cooling, photovoltaic/thermal panel (PV/T), unglazed solar collector, energy efficiency, TRNSYS, simulation, experimental validation.

INTRODUCTION

Given the depletion of non-renewable energy resources, there is a growing interest in natural sources of cooling. The nocturnal sky can be exploited as a natural heat sink, because its effective temperature can reach values 5 to 30°C below ambient temperature [1]. Heat can be emitted mainly through long-wave radiation towards the cold sky, cooling a heat carrier flowing in a panel facing the sky. A summary of the literature is given in Table 1, showing the location, cooling power obtained and type of collector used.

The present study aims at evaluating the cooling potential of photovoltaic/thermal (PV/T) panels and unglazed collectors under the same climatic conditions. In fact, such systems are normally left untapped at night and only used to produce hot water during the day. The cooling power potential of

nighttime radiative cooling under Scandinavian climate is analyzed, validating a theoretical approach with experimental and simulation software based results.

Table 1. Literature review on nighttime radiative cooling applications.

Authors	Type of panels	Average cooling power (W/m ²)	Location
Erell and Etzion [2]	Flat plate radiator	80	Desert areas (Israel)
Anderson et al. [3]	Unglazed solar collectors	50	New Zealand and Australia
Eicker and Dalibard [4]	PV/T	60 to 65	Madrid (Spain) / Shanghai (China)
Hosseinzadeh and Taherian [5]	Unglazed flat plate collector (copper and iron)	23 to 52	Babol (Iran)
Dobson [6]	Radiator panels	60.8	Namibia

METHODS

Experimental setup

The experiment has been carried out on the roof of building 412 at the Technical University of Denmark, Kgs. Lyngby (55°47'02.5"N 12°31'19.9"E), during August 2014. The experimental setup is presented in the schematic layout of Figure 1. The subject panels are three PV/T panels mounted in series (Solarzentrum, 1.3 m² each) and one unglazed collector (2.4 m²), tilted 45° towards South. Data were recorded every ten seconds and time averaged for five minute time steps. The total water flow rate was 3.3 L/min, split in two branches: 2 L/min were supplied to the PV/T panels and 1.3 L/min were supplied to the unglazed collector. The balancing has been made with the balancing valves, so that the flow rate per surface area of collector was equal in both branches, with a value of 0.5 L/min-m². The pump was running 24 hours per day, meaning that during the day, the panels were warming up the circulated water, which was stored in a 1 m³ tank. At night, the water of the tank was then cooled by the panels. Because of this operation, the supply temperature was not the same every night, depending on the daily solar radiation.

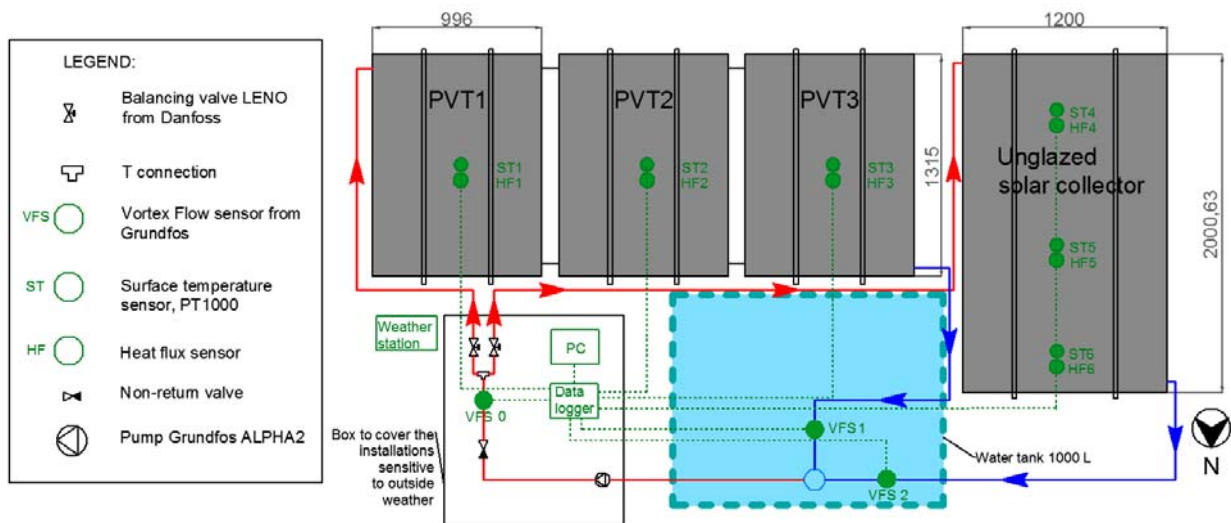

Figure 1. Schematic layout of the experiment.

The total cooling power \dot{Q} [W] of the tested panels was obtained with three methods:

1. Measuring the supply and return water temperatures and flow rate \dot{V} and applying the equation:

$$\dot{Q} = \dot{V} \cdot c_w \cdot \rho \cdot \Delta T \quad (1)$$

Where c_w is the heat capacity of water (4200 J/kg-K), ρ its density (1000 kg/m³), ΔT the temperature difference between the supply and the return (in K), measured by Vortex Flow Sensors (VFS, accuracy $\pm 2^\circ\text{C}^1$) and \dot{V} the volumetric water flow rate (in m³/s), also measured with the VFS (accuracy $\pm 3\%$).

2. With micro foil heat flux sensors attached to the surface of the panels with thermal paste, which directly measure the heat flux between the panel and the environment.
3. Applying a physical model, which, based on the air temperature, wind speed, surface temperature of the panels, their geometry and plane radiant temperature faced by the panels (effective sky temperature), derives the radiative and convective cooling power components.

The obtained results have been compared with those of a simulation software (TRNSYS) where the same weather data as in a night of the experiment was used as input.

Physical model, radiative cooling component

The effective sky temperature T_{sky} is a difficult parameter to estimate. It is defined as the temperature of the equivalent black body that would emit the same amount of long wave radiation [1]. The panels installed are not facing the sky horizontally, they are tilted by 45°. The adopted approach is to consider directly the plane radiant temperature faced by the panels $T_{sky,\perp}$, using two different methods: first with a handcrafted sensor, then the results have been corroborated with measurements from a pyrgeometer, both having the same orientation and angle as the panels. The data from the pyrgeometer were available only for two nights and the pyrgeometer was located within another test facility, 750 meters distant. The real emissivity ε_r of the two collectors' types has been estimated based on the temperature recorded by an infrared thermographic camera and the surface temperature of the panels T_r , measured at the same point by a PT1000 sensor. The values calculated are $\varepsilon_r = 0.91$ and $\varepsilon_r = 0.89$ for the unglazed solar collector and PV/Ts, respectively. Based on the previous parameters, the Stefan–Boltzmann constant σ ($5.67 \times 10^{-8} \text{ W/m}^2 \cdot \text{K}^4$), and the area of the panels A_r , the cooling power due to radiation \dot{Q}_{rad} can be estimated by:

$$\dot{Q}_{rad} = A_r \cdot \varepsilon_r \cdot \sigma \cdot (T_r^4 - T_{sky,\perp}^4) \text{ [W]} \quad (2)$$

The handcrafted sensor used to obtain $T_{sky,\perp}$ measures the plane directional temperature T_g faced by the panel. This measured temperature is affected by convection and radiation. By applying the theory described in EN ISO 7726 Annex B [7], the plane radiant temperature $T_{sky,\perp}$ can be isolated from the measurement, with the following equation:

$$T_{sky,\perp} = 4 \cdot \sqrt{T_g^4 + (h_{cg} / \varepsilon_g \cdot \sigma) \cdot (T_g - T_a)} \quad (3)$$

¹ Given the high inaccuracy of the VFS for temperature measurements, the temperature has been cross checked with a digital thermometer, bringing down the accuracy to $\pm 0.2^\circ\text{C}$.

With:

ε_g is the emissivity of the sensor's surface (-), set to 0.75 (aluminium painted grey)

h_{cg} is the convective heat transfer coefficient of the sensor ($\text{W}/\text{m}^2\text{K}$).

T_a is the outside dry-bulb air temperature (K), measured by the weather station installed on the experiment site.

The plane directional temperature sensor has been constructed by attaching two PT1000 sensors to aluminum heat diffusion plates and a layer of 5 cm insulation in the middle, which is sufficient to prevent influence of one side to the other. The sensors are fixed to the plate with thermal glue. One sensor is in direct contact with the surface of one of the PV/Ts, while the other is facing the sky with the same tilt as the collectors.

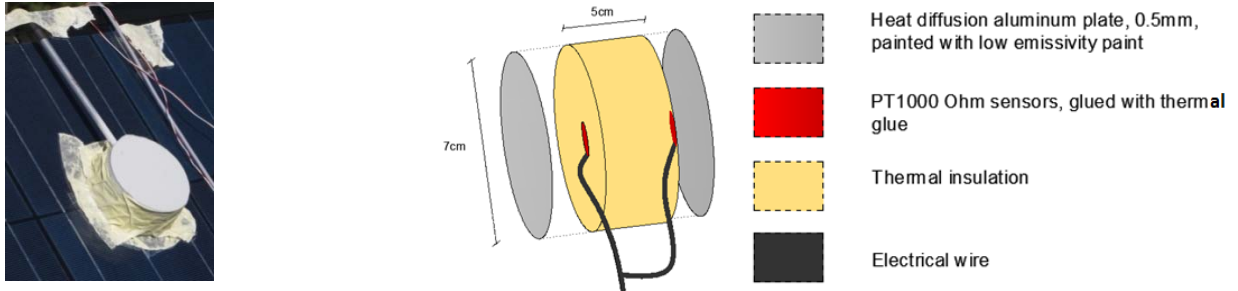

Figure 2. Hand crafted, plane directional temperature sensor.

The pyrgeometer measures the thermal long-wave radiation \dot{q}_{rad} in W/m^2 and it compensates internally for emissivity, hence the following formula applies:

$$\dot{q}_{rad} = \sigma(T_{sky,\perp}^4 - T_{pyr}^4) \quad (4)$$

T_{pyr} is the body temperature of the pyrgeometer. This parameter was not accessible, so it was approximated with the outside air temperature, since the sensor was placed outside. The obtained $T_{sky,\perp}$ is compared with the one calculated previously, for the two nights where both measurements were available (Figure 3, a) and b)). In both cases, the two curves show a similar behaviour along the night. The average difference between the two calculations is 2.4°C for the night of 09/08/2014 and 0.9°C for the night of 11/08/2014. However, the theoretical model based on the handcrafted sensor measurements showed good consistency with other experimental methods.

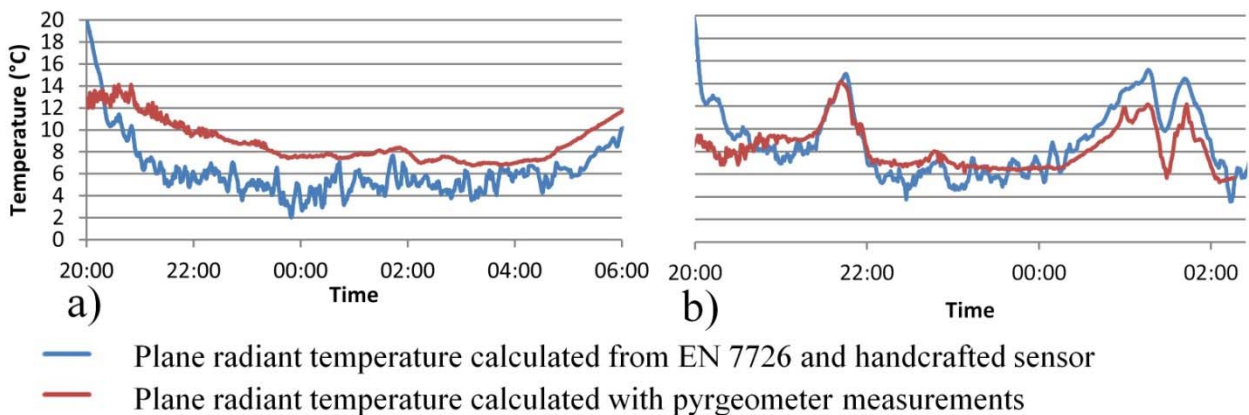

Figure 3. Plane radiant temperatures calculated with both methods. a) The night of the 09/08/2014, b) the night of 11/08/2014.

Physical model, convective cooling component

The convective cooling power \dot{Q}_{conv} can be expressed as a function of the heat transfer coefficient for mixed convection $h_{c,mix}$:

$$\dot{Q}_{conv} = A_r \cdot h_{c,mix} \cdot (T_r - T_a) \quad (W) \quad (5)$$

$h_{c,mix}$ can be obtained in function of the natural $h_{c,nat}$ and forced $h_{c,forced}$ convective components as,

$$\sqrt[3]{h_{c,forced}^3 + h_{c,nat}^3}$$

Two approaches have been investigated and compared:

$$h_{c,forced} = 2.8 + 3 \cdot U_w \quad [1][3] \quad (6) \quad \text{1st}$$

$$h_{c,nat} = 1.78 \cdot (T_r - T_a)^{1/3} \quad [3] \quad (8)$$

$$h_{c,forced} = (k_a / L_{c,forced}) \cdot \overline{Nu}_{forced} \quad [8] \quad (7) \quad \text{2nd}$$

$$h_{c,nat} = (k_a / L_{c,free}) \cdot \overline{Nu}_{nat} \quad [8] \quad (9)$$

The first is a simplified approach. The coefficient for forced convection is a linear function of the wind speed U_w . This method seems to ignore that there is a laminar component, until the critical distance is reached, also when the flow is turbulent, resulting in a higher cooling power.

The second approach considers more in detail the air properties and the geometry of the plate, to define the convective capacity. \overline{Nu} is the mean Nusselt number for the collector's surface, L_c is the characteristic length of the system in meters and k_a the thermal conductivity of the air in W/mK.

RESULTS

The average cooling power for the three methods is presented in Table 2. The average of the three methods is then used for further analysis. In the case of PV/Ts, because of the notable difference in the cooling power obtained with the VFS and the values obtained with the other methods, the first value has been discarded in the calculation of the average cooling energy per night. The cooling energy produced over the night is obtained by integration of the cooling power curves from 19:00 to 07:00. In order to analyze the efficiency of the system, the coefficient of performance (COP) is used. The COP is the ratio of the cooling energy obtained by the energy used by the pump. The circulation pump had an average power of 8 W, which consumes 96 Wh during a night of 12 hours. The COP has been obtained based on the total cooling energy produced by PV/T and unglazed panels since one pump was used to supply both of them. It is therefore mentioned as "COP - Overall" in Table 2.

The cooling energy produced by both types of panels is represented on Figure 4 (values based on the average of three methods). It is important to note that the cooling energy depends on several parameters other than the weather. One of those is the temperature of the water supplied to the panels, which directly affects the surface temperature of the panels and varied every night, depending on the daily radiation. Since the water supply temperature, the surrounding air temperature and the plane radiant temperature faced by the panels affect the most the cooling output, those values have also been plotted on Figure 4. The resulting cooling energy is simultaneously in function of all three parameters, therefore they cannot be read independently.

Table 2. Summarized data during the experiment period, from 12/08/2014 till 25/08/2014.

Date	Average cooling power measured by the heat flux sensors		Average cooling power calculated theoretically (second approach)		Average cooling power measured by the VFS		COP
	W/m ²		W/m ²		W/m ²		
	PV/T	Unglazed collector	PV/T	Unglazed collector	PV/T	Unglazed collector	Overall
12/08/2014	77.4	73.9	71.6	73.7	111.8	68.1	58.8
13/08/2014	68.9	67.3	64.6	69.7	93.1	68.1	56.6
14/08/2014	77.0	74.8	61.1	65.9	100.8	75.8	58.8
16/08/2014	42.2	43.9	30.2	32.2	78.8	38.9	32.5
17/08/2014	32.4	22.6	23.3	24.6	52.8	11.6	19.0
18/08/2014	52.0	49.6	42.5	42.0	76.5	38.8	37.2
19/08/2014	65.7	67.2	55.4	61.8	104.6	72.3	53.2
20/08/2014	62.4	66.1	57.4	65.5	104.5	67.3	52.5
21/08/2014	65.2	69.6	48.2	55.0	106.5	63.9	49.7
22/08/2014	47.5	45.2	28.3	33.0	79.3	35.9	31.5
23/08/2014	68.0	75.3	56.7	69.1	88.2	70.7	55.4
24/08/2014	55.5	60.0	49.7	56.7	89.0	56.7	45.1
25/08/2014	56.4	63.3	48.2	58.9	79.1	54.0	45.5

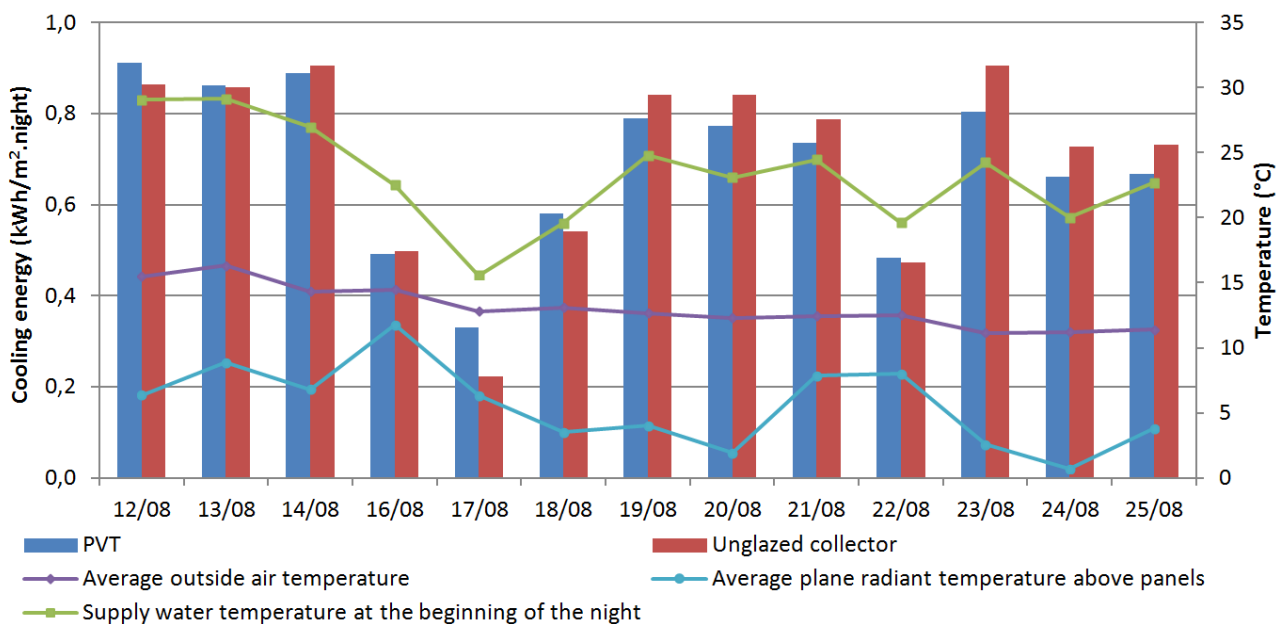

Figure 4. Comparison of the cooling obtained by the PV/T and the unglazed collector per night, from 12/08/2014 to 25/08/2014 (the energy is an average of the outputs of the three adopted method; the supply water temperature at the beginning of the night is averaged from 19:00 until 20:00; the outside air and plane radiant temperatures are averaged from 20:30 till 7:00am).

It can be seen that the difference of production between PV/T and unglazed collector is negligible. It was expected that the PV/T panels would produce less cooling than the unglazed collector, mainly because of the glazing that hinders the heat transfer, shielding the infrared radiation. The results show that this difference was slight, always less than 0.1 kWh/m².night between the two types of panels.

The experimental results have been corroborated with the outputs of a commercial simulation software (TRNSYS), in the case of the unglazed collector. For this purpose, one night was chosen arbitrarily (13/08/2014) for comparison. The weather data (outdoor air temperature, wind speed, effective sky temperature) and the supply water temperature recorded during that night of the experiment have been averaged for time steps of 12 minutes, and given as inputs to the program. The simulation provided a cooling power which is plotted in Figure 5, together with the other power curves.

The results from TRNSYS are relatively close to the ones obtained with other methods. The average cooling power in the simulation shows a value less than 20% higher compared to the average powers observed experimentally and theoretically.

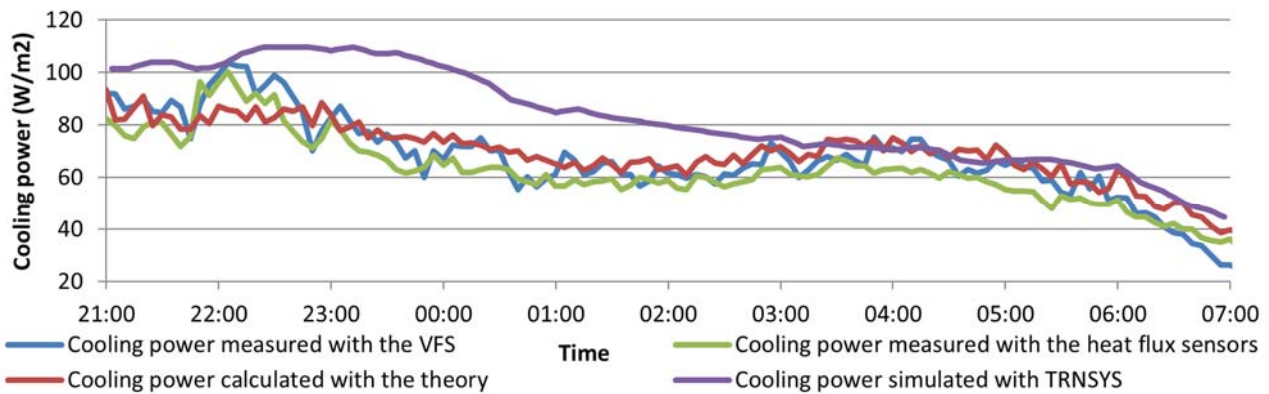

Figure 5. Comparison of the cooling powers of TRNSYS with the other methods, 13/08/2014.

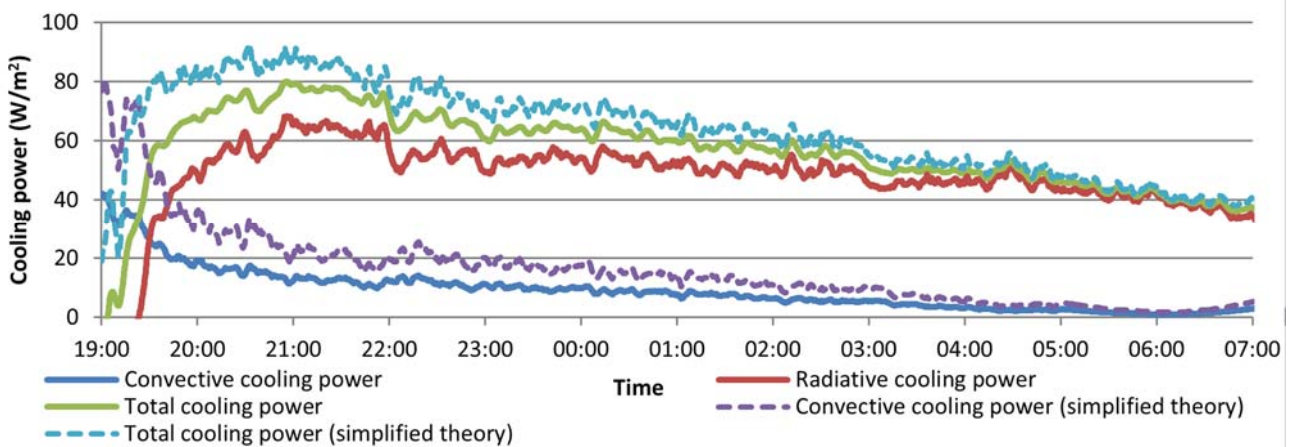

Figure 6. Convective and radiative components of the cooling power for PV/Ts, 20/08/2014. The convective component is calculated with both the theoretical approaches.

DISCUSSION

Figure 6 shows that as expected, the simplified method (first approach, Eq.(6)) increases the convective component up to 50% compared to Eq.(7). However, the cooling provided by convection accounts for around 20% of the total; deviations in the method used to obtain convective power are less evident when it is added to the radiative component. Such a difference is noteworthy but both methods can be used depending on the precision required.

The obtained cooling power ranges from around 25 W/m² during an overcast night until 75 W/m² during a clear sky night. Those values correspond to the expected values found in the literature for similar setups. All three applied methods showed a similar trend of results, except for the VFS when

used with the PV/Ts. The handcrafted sensor used to obtain the $T_{sky,\perp}$ also showed good consistency with the other experimental methods. This tool represents a cheap and convenient solution to estimate the effective sky temperature, which might be worth investigating further.

The COP shows very high values, ranging from 19 to 59 depending on the outside conditions. This justifies the concept of “free cooling” sometimes given to radiative cooling applications: it produces between 19 and 59 times the amount of electrical energy supplied, therefore the technology shows strong potential in energy savings for cooling.

Applications for residential buildings would be more suited to Southern countries where the cooling needs are higher and where solar collectors are already used for water heating purposes. In Nordic countries, the potential is more limited to applications in office buildings, where the internal gains and cooling needs are considerable compared to residential buildings. Moreover, one of the main interests in providing cooling with this technology consists in the contemporaneity occurring between the cooling needs and the potential of cooling production. In fact, clear sky conditions create high solar gains during the days. Provided that the weather conditions are stable, a concurrent higher cooling production is also possible over the nights. Storing the cooling energy for use the following day or for night cooling of the building thus enables to match the demand.

ACKNOWLEDGEMENTS

The authors thank Nico Henrik Ziersen for his valuable help in the setup of the experiments, Prof. Bengt Perers for his guidance on PV/T testing and sky temperature measurements and Dr. Angela Simone for her help in the design of the handcrafted sensors aimed at obtaining sky temperature. This study was financially supported by the Danish Energy Association’s Research and Development Program (ELFORSK), project no. 346-037, “Sustainable plus-energy houses – Part 2: SDE2014”.

REFERENCES

1. Duffie J.A. and Beckman W.A. 2013. Solar Engineering of Thermal Processes, Fourth edition. Wiley, Hoboken, NJ.
2. Erell E. and Etzion Y. 2000. Radiative cooling of buildings with flat-plate solar collectors. Building and environment, Vol. 35, Issue 4, pp. 297-305.
3. Anderson T.N., Duke M., Carson J.K. 2013. Performance of an unglazed solar collector for radiant cooling. Australian Solar Cooling 2013 Conference, Sydney.
4. Eicker U. and Dalibard A. 2011. Photovoltaic-thermal collectors for night radiative cooling of buildings. Solar Energy, vol. 85, pp. 1322-1335.
5. Hosseinzadeh E. and Taherian H. 2012. An Experimental and Analytical Study of a Radiative Cooling System with Unglazed Flat Plate Collectors. International Journal of Green Energy, Vol.9, Issue 8, pp. 766-779.
6. Dobson, R. T. 2005. Thermal modelling of a night sky radiation cooling system. Journal of Energy in Southern Africa, Volume 16, Issue 2, pp. 56-67.
7. EN ISO 7726, 2001. Ergonomics of the thermal environment – Instrument for measuring physical quantities. Brussels: European Committee for Standardization.
8. Zandegiacomo E. 2003. “Appunti di trasmissione del calore”. Università degli Studi di Trieste (in Italian).