



Industrial experience from using the cpm-procedure for developing, implementing and maintaining product configuration systems

Shafiee, Sara; Kristjansdottir, Katrin; Hvam, Lars

Publication date:
2016

[Link back to DTU Orbit](#)

Citation (APA):

Shafiee, S., Kristjansdottir, K., & Hvam, L. (2016). *Industrial experience from using the cpm-procedure for developing, implementing and maintaining product configuration systems*. Paper presented at 18th International Conference on Industrial Engineering , Seoul, Korea, Republic of.

General rights

Copyright and moral rights for the publications made accessible in the public portal are retained by the authors and/or other copyright owners and it is a condition of accessing publications that users recognise and abide by the legal requirements associated with these rights.

- Users may download and print one copy of any publication from the public portal for the purpose of private study or research.
- You may not further distribute the material or use it for any profit-making activity or commercial gain
- You may freely distribute the URL identifying the publication in the public portal

If you believe that this document breaches copyright please contact us providing details, and we will remove access to the work immediately and investigate your claim.

INDUSTRIAL EXPERIENCE FROM USING THE CPM-PROCEDURE FOR DEVELOPING, IMPLEMENTING AND MAINTAINING PRODUCT CONFIGURATION SYSTEMS

The aim of this paper is to analyze the application of a seven-step procedure proposed by Hvam et al. (2001) for developing, implementing and maintaining product configuration systems (PCSs), known as the Center Product Modelling (CPM) procedure. The procedure consists of seven phases which aim to provide a structural approach for PCS projects. The different phases of the framework include: (1) development of the specification processes, (2) analysis of the product range, (3) object-oriented modelling, (4) object-oriented design, (5) programming of the PCS, (6) plan for implementation, and finally (7) plan for maintenance and further development. This research studies the benefits, challenges, and general feedbacks regarding the CPM procedure performance; besides based on the observed challenges, new tools and methods or new research area for future studies are proposed. The result of this study indicates the success of the CPM procedure during the last years as well as reported challenges.

Keywords: CPM (Center Product Modelling) procedure, Product Configuration System (PCS), Product Modelling, Information Systems, Product and Process Design

1. INTRODUCTION

PCSs can be defined as an IT systems used in a specification process, where a set of components along with their connections are pre-defined and additional constraints are used to prevent illegal combinations in order to reduce the solution space (Felfernig *et al.*, 2000). Specification processes can be defined as business processes where the customer's requirements are analyzed and the product is designed to fulfil the customer's needs (Hvam *et al.*, 2008). The benefits from using PCSs has been recognized in terms of better knowledge documentation, use of fewer resources, standardization of products designs, improved certainty of delivery, higher quality and more consistency in the quotation process and increased customer satisfaction (Felfernig *et al.*, 2000) (Zhang, 2014) (Hvam *et al.*, 2010). However, in order to successfully implementing a PCS and achieving the benefits from using the system, organizations have to be aware of avoiding erroneous and suboptimal offers, avoiding mass confusion, complexity handling of needs elicitation, knowledge integration, and finally efficient knowledge management (Felfernig *et al.*, 2014).

Having a systematic procedure for PCSs project management covering the most important activates from development to maintenance should create multiple values for the organizations, which lead to time and resource savings during the project. The research with focus on the scope of PCS have been very limited and specialized (Tiihonen *et al.*, 1996). This lack of focus on scoping often results in both limiting the performance of the PCS and increasing the time and the resource consumption for developing and implementing the configuration system (Shafiee *et al.*, 2014). Several approaches have been developed for managing PCS projects. The frequently used frameworks are presented by Hvam et al. (2001) (2008), Forza and Salvador (2007) (2002) and Tiihonen et al. (1998). CPM framework is one of the most used systematic procedures in industry for PCS projects. The CPM procedure has been tested on some individual cases after it was proposed in 2001 (2001) as the proof of concept and it has been improved during the years and the final version was proposed in 2008 (2008). The procedure is lacking overall testing, which includes and compares more than one case company using the procedure for more than 10 years. In this paper that research opportunity is capture, where it was analyzed to what extent the companies followed the procedure along with the benefits and challenges from using the procedure. Aligned with the focus of the research the following research questions were developed.

- To what extent is the CPM procedure followed at the case companies?
- What are the benefits and challenges reported from using the CPM procedure?

To provide the answers to the research questions five different cases were analyzed over five years period on five different cases. However, the CPM procedure provides structural approach and by following the individual phases of the procedure time and resources can be saved at later stages of the project. However, it was observed for different industrial settings different approaches were required, which resulted in the procedure to be extended to meet different requirements in some cases. Taken that into the account, this paper suggests some additional aspects to be taken into account for further development of the CPM procedure.

2. RESEARCH METHOD

The first phase of the research was devoted to elaborate on the different steps of the CPM procedure. The paper introduces the available tools for each of the phases. The literature evokes the tools proposed for the procedure and other tools suggested by other researchers, which could be beneficial for the CPM procedure.

In order to analyze the usability of the proposed procedure as well as benefits and challenges in different types of industries, multiple case studies were conducted. Case studies typically follow research protocols that combine triangulated multiple data collection methods such as archives, semi-structured interviews, questionnaires, and observations (Eisenhardt, 1989). In this research, combined triangulated multiple data collection was based on the observation and semi-structures interviews. When conducting multiple case studies, attention must be given to the knowledge (resource) triangulation as well as observer triangulation. Triangulation refers to use multiple cases and researchers to strengthen the validity of research. Complementary insights add to the richness of the results and on the other hand, the convergence of observations enhances the confidence in findings (Eisenhardt & Bourgeois, 1988). In this study two researchers observed the process of the CPM procedure utilization and all the challenges and benefits they were gaining during development, implementation, and maintenance of the PCS projects. Finally, alongside the researchers' observations, feedback meetings were held to collect information

about the team satisfaction and challenges or additional requirements and tools while developing and maintaining the PCSs. The understanding of the “how” and “why” is one of the main reasons for using multiple case studies in several disciplines such as operations management and technology management (Darke *et al.*, 1998). Unit of measurement is based on company as different companies with different types of products, culture, size, and complexity have different challenges and expectations from PCS projects.

3. LITERATURE STUDY

The CPM procedure proposed by Hvam *et al.* (2001) consists of seven phases, which aims to provide a structural approach to develop, implement and maintain PCSs. Since the procedure was developed in 2001, several extension and developed have been proposed (2001) (2003) (2006) (2008). Different phases of the framework includes (1) development of the specification processes, (2) analysis of the product range, (3) object-oriented modelling, (4) object-oriented design, (5) programming of the PCS, (6) plan for implementation, and finally (7) plan for maintenance and further development (Hvam *et al.*, 2008). For each of the phases, different tools are suggested. The individual steps of the framework are demonstrated in Figure 1.

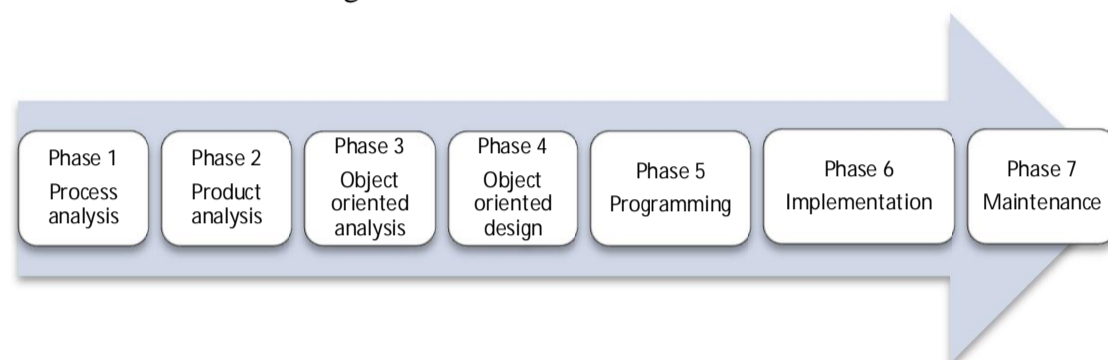

Figure 1. Different phases of CPM procedure (Hvam *et al.*, 2008)

The CPM-procedure emphasizes the cross-disciplinary aspects of building and implementing PCSs, and is derived from research and experiences of different theoretical domains, which include:

- Mass Customization and modularization of the products (Pine *et al.*, 1993)
- Business Process Reengineering (Forza & Salvador, 2007) (Forza & Salvador, 2002)
- Product design and lifecycle (Forza & Salvador, 2007)
- Architecture for building product models (Yang *et al.*, 2009)
- Modeling techniques, such as object-oriented (OO) modeling (Felfernig *et al.*, 2000)
- Software development, object-oriented analysis and design (OOD), knowledge representation and forms of reasoning for expert systems (Felfernig *et al.*, 2000) (Aldanondo *et al.*, 2000)

3.1 Phase 1: Development of Specification Process

The first phase is concerned with analyzing the current specification processes, developing scenarios where PCS can be used to support the future specification processes, and finally identifying the most suitable scenarios based on costs, benefits and risk analysis. Finally, a plan for making the PCS is carried out in this phase. This phase of the framework is divided into 5 steps, which are described in more details in this section.

Step 1: Identification and characterization of the most important specification processes: The purpose of describing the specification process is to get an overview of the most important activities involved in the specification process, their sequences and connections, the ones responsible for different activities, information flows and the processes’ inputs/outputs. Flowcharts can be used to describe the current situation and to describe different scenarios to determine future work (Hvam *et al.*, 2008) (Kruchten, 1998) (Kaufman & Rousseeuw, 2009).

Step 2: Formulation of aims and requirements for the individual specification processes: Project goals are determined by identifying stakeholders’ functional and non-functional requirements. This step aims at increasing the understanding of the project by identifying the main stakeholders’ requirements (Basili & Weiss, 1984). Based on the RUP methods, the stakeholders and their requirements can be drawn up by using process flowcharts (Hvam *et al.*, 2008) and by utilizing the use case diagrams based on RUP methods (Hvam *et al.*, 2008) (Kruchten, 1998). A use case is a pattern for limited interactions between a system and actors in the area of application. Use case diagrams are the means of expressing the requirements and the actors involved in the project (Kruchten, 1998). When clarifying the requirements for the specification process, some of the common tools for strategic planning, such as SWOT¹ analysis, PEST² analysis, and benchmarking can be used.

Step 3: Design of the future specification processes: The design of the future specification processes is conducted by generating different scenarios, and demonstrated how PCSs can be used to support the specification processes to different extent. An important part of the procedure is to invest a great amount of time in the beginning of the project to ensure the feasibility and scoping of the PCS and thereby saving the time in the later stage of the project (Hvam *et al.*, 2008). There are several requirements have to be taken into consideration such as: The purpose of the implementation, identification of the processes supported by the PCS, input and output of the PCS, integration with

¹ SWOT: Description of company’s Strength Weaknesses Opportunities, Threats

² Description of a company’s Political, Economical, Sociological and Technological status

other systems, prioritization of “need to have” and “nice to have” functionalities, Knowledge embraced into the PCS, and identification of users and design of users interface (Hvam *et al.*, 2008).

Step 4: Evaluation and selection of scenarios: Based on these analyses, in the previous steps this step is concerned with evaluating the different scenarios based on benefits, cost and risk and selecting the most potential scenario.

Step 5: Plan of action and organization of further work: The action plan includes tasks, which needs to be done, resources needed for specific tasks and finally how the work is going to be organized and changed.

3.2 Phase 2: Analysis of the product range

A detailed analysis of the product range is necessary and for this purpose, it is suggested to use product variant master (PVM) associated with CRC cards (Figure 2). The PVM presented by Hvam (2001) represents the product knowledge in a structured format from three different aspects, which are customer’s view, engineering view and production/part view. The CRC cards were first proposed (Beck & Cunningham, 1989) as a way to teach object-oriented thinking. Hvam *et al.* (2003) later presented several revised definitions of the CRC cards to be used in PCS projects where they are used to describe the classes in more details.

The analysis of the product range using the PVM does not only give a good overview of the product range but it also indicates the complexity of the product range and none value adding activities (Hvam *et al.*, 2008). The PVM has two structures that are “part-of-structure” and “kind-of-structure”; which are analogous to the structures of aggregation and specialization within object-oriented modelling. The CRC cards were first proposed as a way to teach object oriented thinking. Hvam *et al.* (2008) have later presented several revised definitions of the CRC cards to be used in configuration projects. In Figure 2 an example of the PVM structure and the CRC cards is shown.

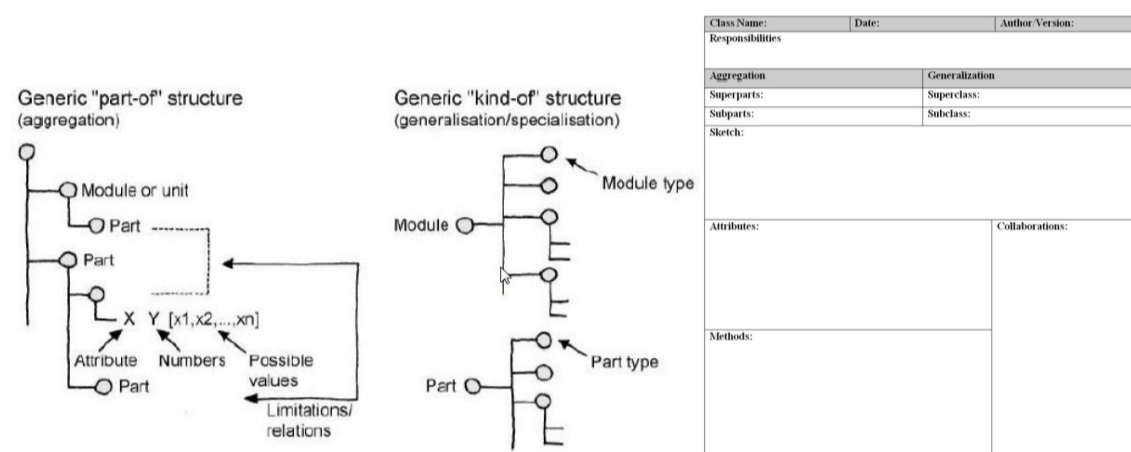

Figure 2. Structure of PVM and CRC cards (Hvam *et al.*, 2008)

3.3 Phase 3 and 4: Object-oriented modeling and Object-oriented design

Unified modelling Language (UML) has been chosen as a notation. A recognized notation from UML is class diagrams and use case diagrams (Bennett *et al.*, 2005) and CRC cards. The class diagram is based on the structure in the PVM and consists of the nodes from the PVM which justify the creation of an object class. CRC cards are used in association with the class diagram and the PVM (Hvam *et al.*, 2008). In Figure 3 an example of class diagram is provided.

In the OOD phase, the focus moves towards being implementation-oriented. The aim of the company is to find the most suitable software that fits the company’s needs, rather than finding the best software (Forza & Salvador, 2007). As listed by Hvam *et al.*, the software functionality is concerned with price and cost calculations, online/offline configuration, report/quote generation, dealing with sub-models, version control of the product model as well as the software, backups and administration of users and systems (Hvam *et al.*, 2008).

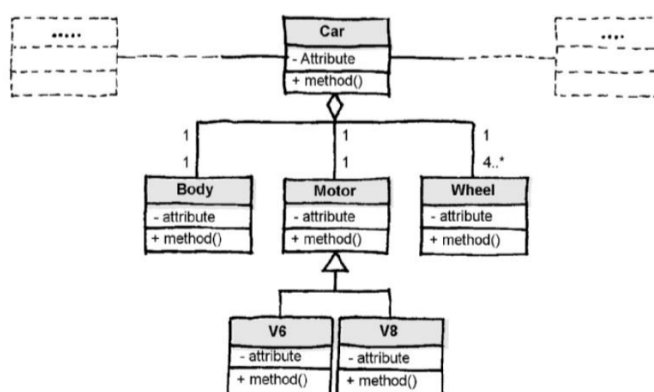

Figure 3. Class diagram is built on the PVM and used when programming the PCS (Hvam *et al.*, 2008)

3.4 Phase 5 and 6: Programming and Implementation

This is the phase where the actual programming takes place and the basis is taken from the OO model, with the class diagram, CRC cards, description of the user interface and etc. In principle the programming can be done in both an object-oriented and in a non-object-oriented

language; as the seven phase procedure is built up around the OO Language, then the preference is to use the OOD developed to implement the system. Graham (1991) emphasizes the following advantages of using an OO programming language, it becomes possible to reuse previous codes, there is a better possibility of extending previous codes and it supports conceptual modelling for analysis and programming which makes complex modelling possible.

After the PCS has been modelled, programmed and tested, it is time for the implementation. According to Hvam et al. (2008) it is important to build up the users' acceptance during the development of the PCS projects where the following aspects should be taken into consideration, make sure that PCS is user-friendly and supports relevant tasks and users' expectations, have the users involved and committed from an early stage of the project to get the best results both for the system developers and all other stakeholders, get selected users for prototype testing, motivate the users by keeping them informed about the new system and indicate the advantages they can expect to gain from it, keep everyone in the organization informed about the project as well as the organizational changes PCS will lead to, a clear explanation to the users to know how their future work situation looks like, provide training for the users to learn how to use the system in the future specification processes so they will find the system convenient to use, and finally reward users who use the system efficiently by introducing monitoring and salary or discount systems. This will help to change the routine working habits in the organization and change the people mind-set to have an efficient solution for the future.

3.7 Phase 7: Maintenance and future development

Studies in companies using PCSs have revealed that without a documentation system, they are unable to develop their configurators and have had to abandon or rebuild their PCSs (Haug *et al.*, 2009). It is, therefore, important to have reliable product documentation, i.e., without technical errors and mirroring exactly the product designs (Forza & Salvador, 2002). The proposed tools for this step is the same visualized modelling techniques (PVM and CRC Cards and class diagrams). Communication between IT personnel (software developers and modellers) and domain experts is an important factor in software development and represents a success factor when discussing changes in software development projects and teams (Stelzer & Mellis, 1998). PVMs and CRC cards are to be used as maintenance and documentation tools beside the task of communication and validation.

4. CASE STUDIES

The unit of measurement in this research has been defined as company. The PCSs considered for the case studies are expected to generate all the needed documents such as bills of material, cost calculations, all technical and commercial proposals and even the process diagrams and product drawings. The needed integration with other systems and improvement in user interface based on the requirements should take into consideration. The complexity is determined based on the size of the projects, which is calculated based on the number of attributes and rules inside the configurator. The number of feedback meetings depends on highly on companies' culture, time and resources as well as the dependency and collaboration with the research team. The background information of the different case studies is presented in Table 1.

Table 1. Background information of the case companies

	Case 1	Case 2	Case 3	Case 4	Case 5
Time frame (years)	10	4	4	8	7
Complexity of the projects	Great	Great	Great	Great/Medium	Great/Medium
No. employees involved	2	2	3	2	4
Number of feedback meetings	2	2	20	3	6

5. RESULTS AND DISCUSSIONS

In Table 1, all the feedbacks from all the cases for 7 steps of the procedure have been listed. The feedbacks are summarized the used tools, benefits and challenges reported in observation, interviews as well as achieved documents.

Table 2. The main result from the case studies where the CPM procedure was used

CPM phases	Suggested tools	Case 1	Case 2	Case 3	Case 4	Case 5
Phase 1: Development of specification processes	Flow charts, activity chains or IDEFO, Gap analyzing Other tools: SWOT and PEST tools Scenario techniques, Benchmarking, Use case diagrams, Project management, Change management	Tools: Flow charts, Gap analysis, Change management, use case diagrams Benefits: In depth understanding of the current situation, easy communication across the team, better evaluation of the future process, easy to use tools Challenges: long lasting discussions to achieve the optimum solution, poor business cases, need of a tool for prioritizing the stakeholders' requirements.	Tools: Flow charts, Gap analysis Benefits: Speaking in a common language with domain experts choosing the most efficient future process from business point of view Challenges: Cost estimation and cost analysis strategies needed for deciding and prioritizing between different projects.	Tools: Flowcharts Use case diagrams, and Gap analysis. Benefits: Analysis of the current situation, deep understanding all PCSs benefits from cost saving to complexity reduction. Challenges: In need of new tools for estimating and comparing the costs, standard guidelines for business cases needed.	Tools: AS-IS and TO-BE processes flowcharts, Business Cases, gap analysis method, use case diagrams, change management techniques Benefits: A very good analysis of cost reduction, process optimization, resources and time reduction, stakeholders' analysis clarified the expectations and roles in the project. Challenges: standard guidelines for business cases needed.	Tools: Flow charts, Gap analysis Benefits: Very good analysis of scenarios and benefit gaining from gap analysis tables Challenges: Contribution ratio were used for calculation which just functional in smaller projects. As there were a lot of uncertainties in the project it was required to use sensitivity analysis to take the uncertainties into the account.

Phase 2: Analysis of product range	PVM, Framework for structuring product knowledge Other tools: Modularization, Scenario techniques, Risk management factors	Tools: PVM, scenario analysis, scenario evaluation Benefits: one step towards documentation and maintenance of the product models, standardization of the products. Challenges: the time-consuming development of visualizing tool manually	Tools: PVM, Product tree structures, scenarios analysis Benefits: Product visualization to enhance the communication, standardization of the product range at the company Challenges: the team has difficulty in accepting PVM as an efficient tool due to the time and energy for their development.	Tools: PVMs, scenarios techniques Benefits: Very close collaboration with product experts due to product visualization Challenges: Time consuming manual task, looking for an automatic cheap solution for modelling.	Tools: Product tree structure, scenarios analysis and selection Benefits: With the product visualization better communication with domain experts was enhanced, Clarifying the product structure. Challenges: PVM updating (this challenge solved by developing and automated documentation system based on PVM and CRC structures)	Tools: PVM, Modularization, scenario analysis, scenario evaluation Benefits: Product visualization to enhance the communication, Modularization for reducing the products range complexities. Challenges: time-consuming tasks of PVM updating, need for a standard way of risk analysis especially for the big projects.
Phase 3: Object-oriented modelling	Class diagram, CRC and other UML diagrams	Tools: Class diagrams and CRC Cards Benefits: all the needed knowledge will be modelled and make everything easy Challenges: Need for changing the work routines.	Tools: CRC Cards and class diagrams Benefits: Easy modelling and design Challenges: no specific challenge was reported.	Tools: Class diagrams Benefits: Easy design in the next phase as all the needed datum are listed in this phase. Challenges: Time-consuming	Tools: CRC cards, Class diagrams, Use case diagrams Benefits: Easy modelling and analysis of the product Challenges: Long workshops	Tools: CRC cards, Class diagrams Benefits: Easy modelling Challenges: Time-consuming
Phase 4: Object-oriented design	Forms of knowledge representation, Criteria for choosing software, Other tools: Other UML diagrams	Tools: Object-oriented knowledge representation, software selection criteria (expenses, user interface, integrations priorities, accessibility and etc.), Use case diagrams Benefits: The list of requirement for selecting software and budget estimation made the whole process more efficient. Challenges: No specific challenge was reported.	Tools: commercial configurator has been selected by determining the requirement using use case diagrams. Benefits: The determined criteria made the system aligned with need at the company. Challenges: No specific challenge was reported.	Tools: Commercial configurator based on the recommended criteria. Benefits: Easy maintenance, easy and fast development phase. Challenges: The maintenance fees for commercial configurators are high.	Tools: Use case diagrams, the commercial configurator is selected based on licenses, maintenance, and main functionalities. Benefits: The selection of commercial software based on the requirements made the maintenance and training process easier. Challenges: No specific method introduced for comparing different software providers and prioritizing the needs.	Tools: commercial configurator with high-performance quality in 3D modelling and integration with CAD systems selected. Benefits: Using the determined criteria and adding specific requirements to them made the selection much easier Challenges: No specific challenge was reported.
Phase 5: Programming	Configuration software	Tools: an object-oriented programming language for homemade configurator plus commercial software Benefits: The commercial configurator help to reduce the time for programming Challenges: The training is needed for the commercial software modelling.	Tools: an object-oriented programming language for homemade configurator plus commercial software Benefits: The team starts to use the commercial software due to benefits and maintain the old homemade software. Challenges: The routines for IT development changed and lots of changes happened.	Tools: Commercial configurator modelling and programming. Benefits: Very fast and easy programming phase, nice user interface without spending a lot of time. Challenges: Extra time for further development based on stakeholders' requirement.	Tools: Commercial configurator programming Benefits: Reduction in resources regarding removing challenges like software functionalities. Challenges: Extra cost for required training.	Tools: commercial configurator programming. Benefits: easy modelling and maintenance, ready integration with CAD systems. Challenges: Costly maintenance, licenses, and training.
Phase 6: Implementation	Plan for implementation, Training of users of the system, testing Other tools: Change management	Tools: User manuals, IT project management Benefits: A standard way of scoping the project leads to reduction in time and resources. Challenges: There are no specific guidelines for different parts of project management in the framework.	Tools: IT project management Benefits: A standard framework for testing, training and releasing the system implemented. Challenges: There is no specific strategy related to testing the PCSs in the framework.	Tools: Project management principles, Project planning based on RUP and UML. Benefits: Efficient project implementation. Challenges: Lots of problems in testing the system and keep stakeholders involved in the project.	Tools: Specific scoping plan for implementation, training workshops Benefits: The team experienced a very efficient way in acceptance, training and etc. Challenges: A long time spent on standardizing the scope, time-consuming workshops for training needed.	Tools: Training workshops, user manuals and videos for the users. Benefits: Training workshop help a lot in changing the routines at the company. Challenges: Need for standardized change management frameworks for PCS projects.
Phase 7: Maintenance and further development	Measurement methods, Plan for organization of the system	Tools: PVM, class diagrams and CRC cards Benefits: Good communication with domain experts Challenges: A lot of time has to be spent on updating and maintaining PVM and CRC cards. There is need for software to automate and ease the process.	Tools: PVM and CRC cards, Class diagrams Benefits: Follow up groups and meeting from the target department and configuration team have been determined to update and maintain the system. Challenges: There is no complain due to a good management and tasks delegation.	Tools: PVM and Class diagrams Benefits: Good communication. Challenges: Strong need for an automatic system for documentation and maintenance and to be away of knowledge duplicating,	Tools: Homemade automatic documentation system in SharePoint (based on PVM and CRC cards structure) Benefits: Very strong communication with domain experts, easy documentation, and maintenance with the least possible time consumption for both parties. Challenges: No specific challenge has reported.	Tools: PVMs, CRC Cards and Class diagrams Benefits: Easy communication Challenges: Very time-consuming process, need for updating the information in multiple systems.

Phase 1: Development of specification processes

Feedbacks: While developing a PCS, it is important to define the knowledge to be incorporated into the system. The experiences show that using Flowcharts and Gap analysis it creates great value for the companies. To demonstrate the current situation helps the team to have in-depth knowledge of the process from the first steps and let them brainstorming for the future scenarios. The future process charts help to make the resources and complexities visible for the stakeholders. The gap analysis allows easy comparison of the current performance and the targeted performance.

Suggested tools: As most of the cases were not able to compare the scenarios scientifically from the financial perspective, the cost-benefit analysis is suggested to be used in phase 1 in order to help them to compare different scenarios or prioritize the projects. Cost-benefit analyses and cost estimation are carried out to compare different scenarios and are an effective method to compare different results from variety of actions (Haddix *et al.*, 2003). Return On Investment (ROI) is commonly used as cost-benefit ratio, which is a performance measure used to evaluate the efficiency of a number of different investments, the ROI is calculated as demonstrated in the formula below (Phillips & Phillips, 2010).

$$ROI = \frac{\text{Gain.from.investment} - \text{Cost.of.investment}}{\text{Cost.of.investment}} \quad (1)$$

Table 3. Examples of ROI and Sensitivity analysis in two different scenarios

Case 1 ROI	The approximate expected development cost (EUR) Scenario 1: 399,785 Scenario 2: 470,335 The expected benefits based on increased sale minus the maintenance work (EUR): Scenario 1: 1,007,862 Scenario 2: 1,068,468 ROI in the first year for scenario 1 = 152,10% ROI in the first year for scenario 2 = 127,17%
Case 1 Sensitivity analysis	Scenario 1: Lower bound: 200,256 EUR Most likely: 1,007,862 EUR Upper bound: 1,350,000EUR Scenario 2: Lower bound: 268,562 EUR Most likely: 1,068,468 EUR Upper bound: 1,453,556 EUR

Finally, in order to take the changes in different parameters into account and to increase the accuracy of the cost analysis, sensitivity analysis is proposed (Table 4). Sensitivity analysis is concerned with representing how the certainty which can be apportioned to different sources of uncertainty in its output (Saltelli, 2002).

After doing the stakeholders' analysis, the MoSCoW rules are commonly used when prioritizing stakeholders' requirements. MoSCoW is derived from the first letters of the following criteria: Must have (Mo), Should have (S), Could have (Co), and finally Want to have (W) (Bittner, 2002). Table 4 is illustrating an example from one of the projects in one of the case studies.

Table 4. Examples of stakeholders' requirement prioritization

List of requests	Must have	Should have	Could have	Want to have
Technical proposals (sales people and cost estimators)		✓		
Table generation (sales, cost estimators and marketing group)			✓	
Price calculation and scope of supply (all stakeholders)	✓			

5.2 Phase 2: Analysis of Product Range

Feedbacks: In this phase, the PVM and CRC Cards modeling techniques were used and the reason was the familiarity with these specific methods in the case companies using visualized modelling techniques. After doing the PVM, the programming in the configurator was easy and fast and they had a documentation and communication tool as well which leads to an easy communicate with domain experts. Communicating with stakeholders from the first steps in the project would be very helpful by creating the feeling of ownership between them. This step was one of the steps which reported as a challenge due to the manual work; besides in the companies which are benefiting from IT software to reduce the manual tasks, it was reported as a very beneficial tool both for communication and documentation.

Suggested tools: There is available literature which is proposing new ways of documentation and modelling in an automatic way (Haug, 2007) (Shafiee *et al.*, 2015). The suggested solutions provided the companies with an easy solution regarding modelling and documentation.

5.3 Phase 3: Object-Oriented Modelling and Object-Oriented Design

Feedbacks: The main outputs of the OO for the problem domain are the class diagrams and CRC cards. These tools make the process of stakeholders' analysis official and establish a strong relationship between configuration team and stakeholders. This phase will reflect on the structure and modelling of PCS in the next phases. The challenge was regarding workshops and gathering all the users of system from top managers to engineers in one session with the acceptance perception.

This phase assigns to the software selection, adopting the object-oriented model to the software, and definition of the requirement specification for programming. A list of requirement and specification for the needed software such as possibility of integration with other

systems, reliability or response time prepared. In all the cases, this phase should have done much sooner and as specific configuration system had been chosen at this point.

5.4 Phase 5: Programming and implementation

Feedbacks: Based on the software selected in the previous phase, the programming will be different. When selecting a commercial PCS, the tasks of modelling will face less IT challenges compared with other configurators programmed internally. The concern of this phase is to select the software in adaptation with object-oriented model. In this phase the team should determine how the implementation process has been considered until now as well as providing recommendations for the future implementation process regarding user-friendliness and acceptance, testing plan, training plan and totally scoping of the system.

The testing of the system is one of the most reported challenges in the implementation phase. As reported, the users might start using the system in a stage that the system is stable and validated, otherwise the system will be out of credit for them. The testing has been fulfilled based on test cases and then domain experts have been involved for further testing. In most of the cases, the system validation from business side was an issue.

Suggested tools: An iterative processes and iterative testing enable feedback in the early phases of a project (Kruchten, 1998). Numerous methods exist for iterative project testing and validation, eliminating unnecessary debugging process at the end of the project (Hirsch, 2002). Based on RUP methods and Kruchten (1998), there are different levels of testing for IT projects as well as PCSs as bellow:

1. Unit testing: the smallest elements of the system are tested.
2. Integration testing: the integrated units as subsystems are tested.
3. System testing: the complete application and system are tested.
4. Acceptance testing: The complete system is tested by the end users to determine readiness of the system.

5.7 Phase 7: Maintenance and Further Development

Feedbacks: The maintenance and further development will be done in an efficient and effective manner. Maintaining the system in CPM procedure interpret as updating the class diagram, CRC cards and PVM. The PVM and the CRC cards should be used for the knowledge to be incorporated to the system while the class diagram and the CRC cards will be used for programming purposes; and both are critical for the further developments.

Suggested tool: The ideal situation is to have an agile documentation system and exchange the knowledge inside the PCS with domain experts to allow them to test, verify and update the knowledge inside the system iteratively (Shafiee *et al.*, 2015); this system has been developed and utilized in one of the cases.

6. CONCLUSION

The paper evaluates the performance of the procedure and follows it up with recognizing the roots of organizational challenges in different phases; and briefly, mentions to a couple of solutions related to critical challenges. Further studies needed to focus deeply on each of the reported challenges and provide the industries with scientific solutions.

The CPM procedure is used at the case companies with the proposed structure but based on the different requirements, some changes have been done. Most of the changes which have been mentioned previously are regarding a new tool or technique which has been added in different steps.

The analysis at the companies should lead to informed decisions regarding whether it provides value for the business to implement a PCS. There are some challenges reported regarding the lack of tools or techniques for different analysis in some of the steps. It seems the more complicated and bigger the projects are the more challenges are reported. The paper aims to suggest new tools briefly and leave the details for the future studies. For example, there is no specific discussion in the CPM procedure regarding sensitivity analysis which could be considered as one of the improvements in the first phase of the procedure. Stakeholder analysis and prioritization can be elaborated more in phase one. A comprehensive stakeholders' analysis would have a great influence on whole procedure clarification. In modelling phase, challenges regarding the needs for a fast and efficient visualization tool in order to model and document the products information were identified. In the implementation phase, there is the possibility to improve the guidelines in the project management skills. Risk management and change management principles could be elaborated and new tools would be helpful for the project manager and the whole team. IT project testing principles suggested to be used as an inspiration to improve the testing phase of the projects but there are potentials and requests to study and improve the testing phase of PCSs in general.

REFERENCES

- Aldanondo, M., Rouge, S. & Ve, M., (2000). Expert configurator for concurrent engineering: Came´ le´ on software and model. *Journal of Intelligent Manufacturing*, 11(2):127-134.
- Basili, V. R. & Weiss, D. M., (1984). A Methodology for Collecting Valid Software Engineering Data. *IEE transactions on software engineering*, 10(6):728-738.
- Beck, K. & Cunningham, W., (1989). A Laboratory for Teaching Object-Oriented Thinking, Object-Oriented Programming Systems. *Languages and Applications*, 24(10):1-6.

- Bennett, S., McRobb, S. & Farmer, R., (2005). *Object-oriented systems analysis and design using UML*. McGraw Hill.
- Bittner, K., (2002). *Use case modeling* Addison-Wesley Longman Publishing Co., Inc.
- Chao, P. & Te Chen, T., (2001). Analysis of Assembly Through Product Configuration. *Computers in Industry*, 44(2):189-203.
- Darke, P., Shanks, G. & Broadbent, M., (1998). Successfully completing case study research: combining rigour, relevance and pragmatism. *Information systems journal*, 8(4):273-289.
- Eisenhardt, K., (1989). Building theories from case study research. *Academy of management review*, 14(4):532-550.
- Eisenhardt, K. & Bourgeois, L., (1988). Politics of strategic decision making in high-velocity environments: Toward a midrange theory. *Academy of Management Journal*, 31(4):737-770.
- Felfernig, A., Hotz, L., Bagley, C. and Tiihonen, J., (2014). knowledge-based Configuration: From Research to Business. *Benefits of configuration systems. Cases*. Felfernig, A., Bagley, C., Tiihonen, J., Wortley, L. and Hotz, L., Elsevier, 29-33.
- Felfernig, A., Jannach, D. & Zanker, M., (2000). Contextual diagrams as structuring mechanisms for designing configuration knowledge bases in UML. *Proceeding of International Conference on the Unified Modeling Language*. Berlin Heidelberg Springer , 240-254.
- Forza, C. & Salvador, F., (2002). Managing for Variety in the Order Acquisition and Fulfillment Process: The Contribution of Product Configuration Systems. *International Journal of Production Economics*, 76(1):87-98.
- Forza, C. & Salvador, F., (2007). *Product Information Management for Mass Customization: Connecting Customer, Front-office and Back-office for Fast and Efficient Customization*. New York: Palgrave Macmillan.
- Graham, I., (1991). *Object-oriented methods*. Addison-Wesley Publishing Company.
- Guðlaugsson, T., Ravn, P., Mortensen, N. & Sarban, R., (2014). Front-end conceptual platform modeling. *Concurrent Engineering*, 22(4):267-276.
- Haug, A., (2007). *Representation of Industrial Knowledge – As a Basis for Developing and Maintaining Product Configurators*, Lyngby: Technical University of Denmark.
- Haug, A. & Hvam, L., 2008. Representation of Industrial Knowledge-as a Basis for Developing and Maintaining Product Configurators. PhD Thesis, Department of Management Engineering, Technical University of Denmark.
- Haug, A., Hvam, L. & Mortensen, N. H., (2009). Implementation of conceptual product models into configurators: From months to minutes. *Proceeding of 5th World Conference on Mass Customization and Personalization*.
- Hirsch, M., (2002). Making RUP Agile, In OOPSLA 2002 Practitioners Reports.
- Hvam, L., (2001). A procedure for the application of product modelling. *International Journal of Production Research*, 39(5):873-885.
- Hvam, L., Haug, A. & Mortensen, N., (2010). *Assessment of benefits from product configuration systems. Proceeding of 13th Workshop on Configuration*.
- Hvam, L., Mortensen, N. H. & Riis, J., (2008). *Product Customization*, Springer.
- Hvam, L. P. S. & Nielsen, M., (2006). Improving the quotation process with product configuration. *Computers in Industry*, 57(7):607-621.
- Hvam, L., Riis, J. & Hansen, B., (2003). CRC cards for product modelling. *Computers in Industry*, 50(1):57-70.
- Jinsong, Z., Qifu, W., Li, W. & Yifang, Z., (2005). Configuration-oriented product modelling and knowledge management for made-to-order manufacturing enterprises. *The International Journal of Advanced Manufacturing Technology*, 25(1-2):41-52.
- Kaufman, L. & Rousseeuw, P., (2009). *Finding groups in data: an introduction to cluster analysis*. John Wiley & Sons.
- Kruchten, P., (1998). *The Rational Unified Process: An Introduction*. New York: Addison-Wesley.
- Magro, D. & Torasso, P., (2003). Decomposition Strategies for Configuration Problems. *Artificial Intelligence for Engineering Design, Analysis and Manufacturing*, 17(01):51-73.

- Haddix, A.C., Teutsch, S.M. and Corso, P.S., (2003). *Prevention effectiveness: a guide to decision analysis and economic evaluation*. Oxford University Press.
- Paetsch, F., Eberlein, A. & Maurer, F., (2003). Requirements engineering and agile software development. *Proceeding of IEEE 12st International Workshop on Enabling Technologies: Infrastructure for Collaborative Enterprises*.
- Phillips, P. & Phillips, J., (2010). *Return on investment*. John Wiley & Sons, Inc..
- Pine, B., Victor, B. & Boynton, A., (1993). Making mass customization work. *Harvard business review*, 71(5):108-11.
- Saltelli, A., (2002). Sensitivity analysis for importance assessment. *Risk Analysis*, 22(3):579-590.
- Shafiee, S., Hvam, L. & Bonev, M., (2014). Scoping a Product Configuration Project for Engineer-to-Order. *International Journal of Industrial Engineering and Management (IJIEM)*, 5(4):207-220.
- Shafiee, S., Hvam, L. & Kristjansdottir, K., (2015). An agile documentation system for highly engineered, complex product configuration systems. *Proceeding of 22st EurOMA Conference, 2014, European Operations Management Association*.
- Stelzer, D. & Mellis, W., (1998). Success factors of organizational change in software process improvement. *Softw Process Improv Pract*, 4(4):227-250.
- Tiihonen, J., Heiskala, M., Anderson, A. & Soininen, T., (2013). WeCoTin—A practical logic-based sales configurator. *AI Communications*, 26(1):99-131.
- Tiihonen, J., Lehtonen, T., Soininen, T., Puikkinen, A., Sulonen, R. and Riitahuhta, A., (1998). Modeling configurable product families. *Proceeding of 4th Workshop on Product Structuring*.
- Tiihonen, J., Soininen, T., Männistö, T. & Sulonen, R., (1996). State of the practice in product configuration—a survey of 10 cases in the finnish industry. *Knowledge intensive CAD*, 95-114.
- Tseng, H., Chang, C. & Chang, S., (2005). Applying Case-Based Reasoning for Product Configuration in Mass Customization Environment. *Expert Systems with Applications*, 29(4):913-925.
- Yang, D., Miao, R., Wu, H. & Zhou, Y., (2009). Product configuration knowledge modeling using ontology web language. *Expert Systems with Applications*, 36(3):4399-4411.
- Zhang, L., (2014). Product configuration: a review of the state-of-the-art and future research., *International Journal of Production Research*, 52(21): 6381-6398.