



## Analysis of plant performance with improved turbine flexibility: Test case on a parabolic trough configuration

Topel, Monika; Ferruzza, Davide; Seeger, Fabian; Laumert, Björn

*Published in:*  
AIP Conference Proceedings

*Link to article, DOI:*  
[10.1063/1.5067088](https://doi.org/10.1063/1.5067088)

*Publication date:*  
2018

*Document Version*  
Publisher's PDF, also known as Version of record

[Link back to DTU Orbit](#)

*Citation (APA):*  
Topel, M., Ferruzza, D., Seeger, F., & Laumert, B. (2018). Analysis of plant performance with improved turbine flexibility: Test case on a parabolic trough configuration. *AIP Conference Proceedings*, 2033(1), Article 070002. <https://doi.org/10.1063/1.5067088>

---

### General rights

Copyright and moral rights for the publications made accessible in the public portal are retained by the authors and/or other copyright owners and it is a condition of accessing publications that users recognise and abide by the legal requirements associated with these rights.

- Users may download and print one copy of any publication from the public portal for the purpose of private study or research.
- You may not further distribute the material or use it for any profit-making activity or commercial gain
- You may freely distribute the URL identifying the publication in the public portal

If you believe that this document breaches copyright please contact us providing details, and we will remove access to the work immediately and investigate your claim.

## Analysis of plant performance with improved turbine flexibility: Test case on a parabolic trough configuration

Monika Topel, Davide Ferruzza, Fabian Seeger, and Björn Laumert

Citation: *AIP Conference Proceedings* **2033**, 070002 (2018); doi: 10.1063/1.5067088

View online: <https://doi.org/10.1063/1.5067088>

View Table of Contents: <http://aip.scitation.org/toc/apc/2033/1>

Published by the *American Institute of Physics*

---

### Articles you may be interested in

Identification of optimum molten salts for use as heat transfer fluids in parabolic trough CSP plants. A techno-economic comparative optimization

*AIP Conference Proceedings* **2033**, 030012 (2018); 10.1063/1.5067028

---

**AIP** | Conference Proceedings

Get **30% off** all  
print proceedings!

Enter Promotion Code **PDF30** at checkout



# Analysis of Plant Performance with Improved Turbine Flexibility: Test Case on a Parabolic Trough Configuration

Monika Topel<sup>1, a)</sup>, Davide Ferruzza<sup>2, b)</sup>, Fabian Seeger<sup>3</sup> and Björn Laumert<sup>1</sup>

<sup>1</sup>*Heat and Power Division, KTH Royal Institute of Technology, Brinellvägen 68, 100 44, Stockholm, Sweden.*

<sup>2</sup>*Department of Mechanical Engineering, DTU, Denmark Technical University, 2800, Kgs, Lyngby, Denmark*

<sup>3</sup>*ITSM, University of Stuttgart, Pfaffenwaldring 6, 70569, Stuttgart, Germany*

<sup>a)</sup>Corresponding author: [topel@kth.se](mailto:topel@kth.se)

<sup>b)</sup>[daferr@mek.dtu.dk](mailto:daferr@mek.dtu.dk)

**Abstract.** Parabolic trough configurations account for 95% of the current installed concentrating solar power (CSP) capacity. Certainly this technology is considered as the most mature among other CSP types. However, regardless of its maturity, the pursuit of cost competitiveness with respect to fossil fuels and other renewables is still a dire need. One way to maximize profitability and improve performance is flexibility through fast starts. In this regard, the steam turbine has been identified as a key limiting component to the start-up process. This work focuses on analyzing the influence of steam turbine start-up parameters on the overall annual performance of a CSP plant. For this, a detailed parabolic trough power plant (PTPP) performance model was developed including a control strategy to account for turbine transient start-up constraints. The PTPP model was developed in accordance to the latest state-of-the-art of the technology. As such, the first part of the results consisted of validation studies of the model with respect to the actual power plant. The results obtained in this regard showed that the model correlates to the rated performance of the power plant with maximum errors of 12% and of 14% to the dynamic operation of the power plant. The second part of this work consisted of using the validated model in a series of sensitivity studies concerning the variation of different turbine start-up parameters. Results showed that improvements of up to 1.8% in the annual electricity production are possible with only 0.3% increase in fuel consumption.

## INTRODUCTION

Among concentrating solar power (CSP) technologies, parabolic trough configurations are the most mature and economically viable at a large-scale [1]. In the past 7 years, the global CSP capacity has grown over 7 times up to the currently installed 4.7 GW [2] [3]. While it is true that a significant portion of this growth has been from tower-based configurations, parabolic trough technology remains the most dominant one, accounting for 95% of the current global installed CSP capacity. However, there are still certain challenges to overcome in order to continue the development of the technology. On the technical side, the inherent fluctuations of the solar supply pose operating requirements to which certain crucial power plant components are not fully designed to fulfill. On the economic side, CSP systems have not yet reached competitive prices with respect to conventional technologies [4] or even other renewables [5]. Both these aspects lead to a hindrance of the actual forecasted deployment of the technology [6]. Thus, technological improvements at both component and system level represent an opportunity towards increasing performance and reducing costs.

Among the proposed options [7][3][8] to address the technical and economic challenges mentioned above, one improvement is related to optimizing the power block to meet the daily start-up and shutdown cycles of the plant from the fluctuations and intermittencies of the solar resource supply. By improving operating flexibility, energy losses during transient operation can be mitigated, leading to an increase in the energy production of the CSP plant. This, in turn, improves its profitability and availability. One key aspect of operational flexibility, in the CSP context of daily cyclic operation, is the capability for fast starts. This even applies to CSP configurations with integrated thermal

energy storage given that prior studies [9] have shown that, for certain market conditions, the most profitable operating strategies imply an increased amount of annual starts in order to peak the operation of the plant during the highest electricity prices.

As such, in the interest of improving the annual performance and competitiveness of parabolic trough CSP plants, it is desirable to achieve fast start-up times to harness the solar energy as soon as possible. On the other hand, in the interest of preserving component lifetime it is necessary to set limitations during start-up operation. The start-up speed of the whole plant is limited by the thermal behavior of certain key components, one of which is the steam turbine. During start-up operation, the variation of the incoming steam conditions provokes temperature gradients within the turbine metal. As a result, the ramp rate at which the steam turbine can start is typically constrained by thermal stresses which must be carefully controlled during the start-up process. In common industrial practice, turbine manufacturers define a discrete number of start-up schedules to operate the machine under allowable thermal limits. In general, the warmer the turbine is before start-up, the faster the start-up can be.

The state of the art know-how of steam turbine start-up has its roots in conventional power generation applications, which does not have such a variable operating conditions as CSP. Thus, the steam turbine industry mainly applied designs of turbines suited for conventional power generation practices only with more flexible operating constraints. Previous experience has shown that the steam produced by the solar field was not fully utilized for power production in the turbine [10], which has set the tendency towards implementing retrofitting measures [11][12] and other improvements [13] once the turbine has been commissioned. In some cases these turbine modifications have been found to yield up to 4.7% improvements in the annual production of a CSPP. This iteration between the power plant operator and the turbine manufacturer towards higher flexibility still merits further investigation. In order to fully adapt to the transient operating conditions of CSP, it becomes important to make full use of the turbine's flexibility by avoiding over-conservative or sub-optimal limitations in the design process of such schedules while still ensuring the safe operation of the machine. In order to achieve this, this work studies the influence of steam turbine start-up parameters on the overall annual performance of a CSP plant. The case at hand is based on previous studies by the authors which describe in detail the implementation of strategies on the steam turbine to increase its flexibility [12][13] and the effect on the power plant for tower-based systems has also been investigated [14] [15]. For this, a detailed parabolic trough power plant (PTPP) performance model was developed including a control strategy to account for turbine transient start-up constraints. This model was first validated in its steady-state and dynamic operation and then used in sensitivity studies in which a different start-up parameter was varied.

## MODEL DEVELOPMENT

The modeling of the PTPP performance carried out in this work has been done using DYESOPT, an integrated tool capable of performing power plant design, performance evaluation and equipment costing that has been previously developed [10][17] at the Royal Institute of Technology (KTH). To perform a techno-economic assessment, DYESOPT requires location specific inputs as well as power plant design specifications and component cost functions. These inputs allow the design of the power plant at nominal conditions to be achieved. Moreover, the design parameters are then used for an annual dynamic simulation using TRNSYS, the results from which are used to calculate relevant performance indicators involving both technical and economic aspects of the modeled power plant. **FIGURE 1** schematizes a simplified version of the flow of information and calculations within the tool, in which the required input is differentiated by colors depending on the nature of the data: design configuration related (orange), location related (blue) and cost functions (green).

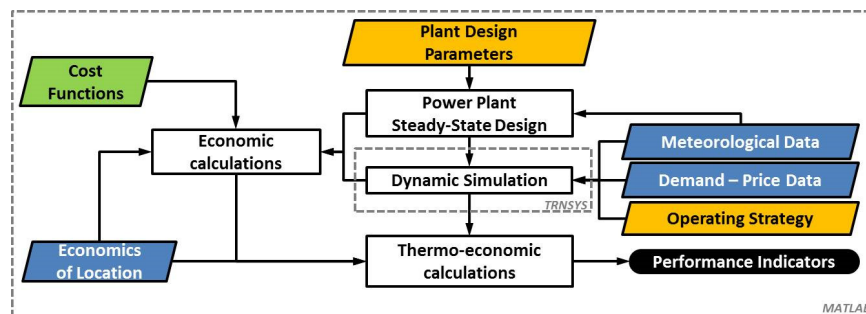

**FIGURE 1.** Simplified schematics of information flow in DYESOPT

A schematic representation of the modeled PT-CSPP layout is shown in **FIGURE 2** along with the power plant's nominal design specifications in **TABLE 1**. The nominal layout was developed following the latest state of the art of PTPP technology [18] [19]. In general, the layout has a solar field (SF) composed of parabolic trough collectors that concentrate the solar energy into focal lines where the heat transfer fluid (HTF) is flowing. Alternatively, in the absence of solar irradiation, a gas fired HTF heater (HTFH) can be used to increase the temperature of the thermal oil. The heated HTF is then directed to the steam generator (SG) composed of superheater (SH), evaporator (EV) and economizer (EC) where it exchanges its heat to incoming saturated water. The water leaves the SG in the form of steam to enter a gas fired booster heater (BH) which raises steam conditions before the inlet to the turbine. The superheated steam powers a Rankine cycle with regeneration. The power block (PB) layout comprises a steam turbine (ST) with extractions to closed feed-water heaters and to a deaerator (D). Furthermore, the condensing process is done with an air cooled condenser (ACC). The equations governing these models were extracted from [20] and [21] for the power block, from [22] for the HTF cycle and from [23] and [24] for the solar field.

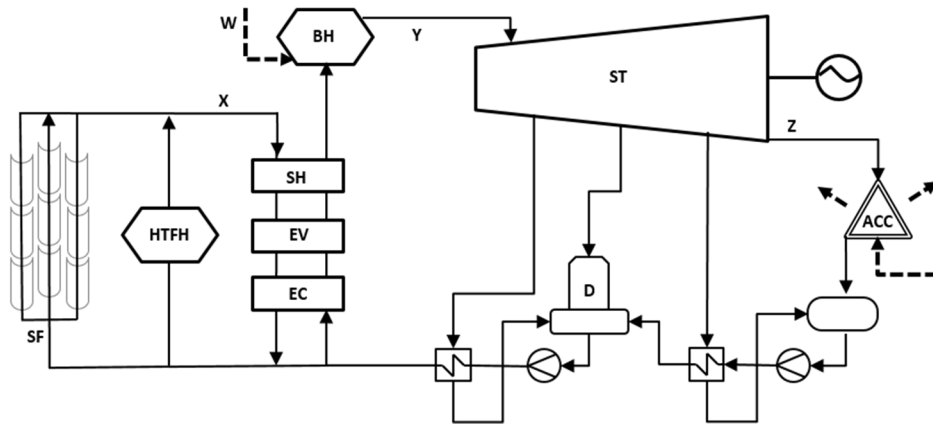

**FIGURE 2.** Schematic layout for the modeled parabolic trough solar power plant.

**TABLE 1.** Design specification parameters for the modeled power plant

Parameter	Value
Location	Abu Dhabi
Heat Transfer Fluid	Thermal Oil
Solar Field Aperture	627 840 m <sup>2</sup>
Solar Field Outlet Temperature	400 °C
Power Cycle	Rankine with regeneration
Turbine Capacity	100 MW
Turbine Inlet Pressure	100 bara
Turbine Inlet Temperature	540 °C
Cooling Method	Dry

### Start-up Strategy

In order to be able to carry out the studies set for this work was the implementation of a control strategy for the start-up of the plant, especially for the start-up of the steam turbine. First, the cool-down behavior of the turbine was modeled in accordance to the lumped capacitance method [20]. By doing this, it was possible to calculate the turbine metal temperature throughout its operation, with a special interest during offline periods. Then, the turbine start-up behavior was included by determining which start-up schedule is to be carried out. This is performed by going through the number of curves that are available  $n_{start}$ , from coldest to warmest, and compare the turbine calculated temperature with the one required by the curve. Doing this automatically implies that the minimum required steam admission conditions are also defined. The turbine start begins only when these conditions are fulfilled on both the turbine metal and the steam conditions. Furthermore, once the start-up curve corresponding to the temperature state

of the turbine is determined, this also defines the time for the turbine to reach synchronization speed,  $SD$  and the time for the turbine to reach full load,  $RD$ . It is important to highlight that one set of these parameters corresponds to one start-up curve. **FIGURE 3** is a representation of the start-up parameters within a typical turbine schedule. The dynamic simulation executes the start of the turbine each time in accordance to this control logic and to the respective parameters.

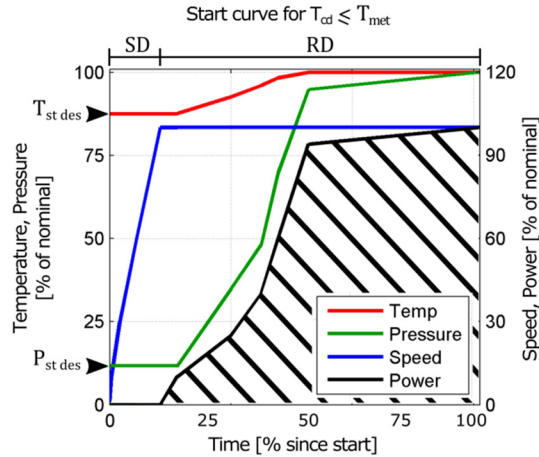

**FIGURE 3.** Turbine start parameters represented within a start-up schedule.

## MODEL VALIDATION

Once the model was developed following the same specifications and sizing of the built power plant, the next step was to validate it. This was done by comparing the model against the rated specifications of the power plant for nominal operation and also against measured data during daily operation. With regards to the modeling steps within DYESOPT these comparisons correspond to validating the resulting values of the steady state design and dynamic simulation of the model.

### Steady State Design Validation

The steady state validation consisted of verifying that the sizing of all power plant components within the DYESOPT tool was done in accordance to the rated specified heat and mass flow conditions of the installed power plant. **TABLE 2** shows the heat load proportions corresponding to the power plant design for different subsystems within the layout normalized against the total heat load required by the power block. The table also shows the relative error of the model with respect to such values. Likewise, **TABLE 3** shows the mass flow proportions for certain key lines of the power plant layout (**FIGURE 2**) normalized against the turbine inlet conditions and the error of the model with respect to those values. In general, for both the heat a load cases it can be said that the model steady-state sizing matches that of the power plant satisfactorily, with errors averaging within 5-8% and a maximum error of 12.3% for the power block parasitic consumption.

**TABLE 2.** Heat load proportions from data for the nominal operation of the power plant and comparison to obtained results from model steady state design.

Subsystem (Fluid)	Nominal Heat Loads [% of PB <sub>th</sub> ]	Model Error [% to Data]
Solar Field (HTF)	82.01	5.73
Steam Generator (Steam)	81.54	5.19
Booster Heater (Steam)	22.51	7.84
Condenser (Water)	60.29	0.72
Power Block Gross (Steam)	39.38	1.91
Power Block Paras (Steam)	4.38	12.30

**TABLE 3.** Mass load proportions from data for the nominal operation of the power plant and comparison to obtained results from model steady state design..

Flow Rate (Fluid)	Nominal Mass Loads [% of Y]	Model Error [% to Data]
X (HTF)	931.67	8.30
Y (Steam)	100	6.40
Z (Steam)	72.66	5.56
W (Gas)	21.40	7.11

### Dynamic Behavior Validation

The dynamic validation consisted of comparing the behavior of the model during a day of operation against historical data provided by the power plant operator. It is important to clarify that for this study the only data that is being used as an input to the model is the DNI and weather conditions for the given day of comparison. While the remaining flow and temperature values comprised within the data were used to benchmark with those calculated as output from the model. As such, there is no correlation being done with the data by means of regressions but only through physical equations. The dynamic results from the model and the data from the plant are shown below. Similar to the steady-state validation section, these were organized in terms of heat loads, **FIGURE 4a**, and mass flows, **FIGURE 4b**. In general, it is considered that the model follows the same behavior of the historical data of the plant. However, it can also be seen that the model has certain over predictions of energy and flows during the ramping up process. These are caused by differences in the solar field performance which translate to the other subsystems. The differences in dynamic behavior between the model and the data amount to 14% in the power production of the plant. As such, for the purpose of the upcoming studies in this work it is considered that the model has a validated behavior with regards to the reference PTPP.

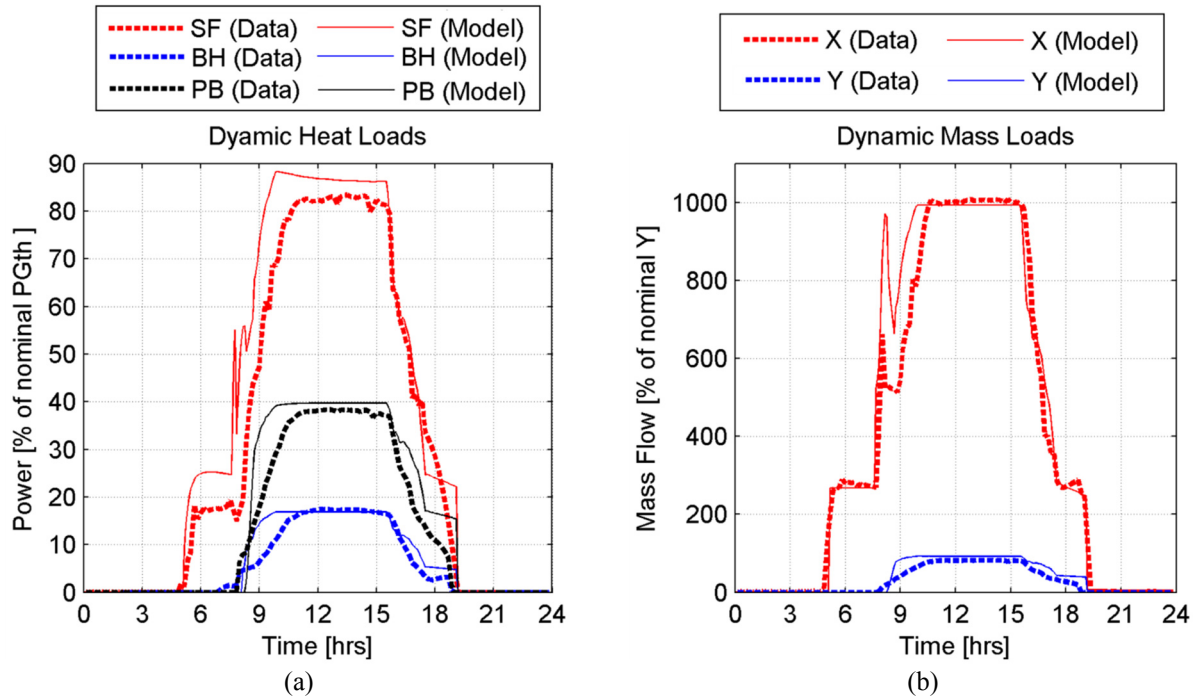

**FIGURE 4.** Comparison of dynamic operation between historical data and performance model for (a) heat loads and (b) mass loads during a day of operation.

## PLANT PERFORMANCE IMPROVEMENTS

The next step of this work was to perform sensitivity studies of turbine start-up parameters on the annual electricity production and the annual energy use of fossil fuel. As it can be seen on the power plant layout on **FIGURE 2**, fossil fuel firing is an inherent part of this plant's operation. As such, the main intention with these sensitivity comparisons is to understand where the highest gains on production can be made with the lowest costs on fuel consumption through improving turbine flexibility at start-up. **TABLE 4** lists the five sensitivity cases that were studied along with the parameter being varied on each case. It is important to highlight that for cases A-D the parameters were varied by  $\pm 20\%$  from the validated values, while case E was varied by adding one additional start-up curve level each time.

**TABLE 4.** Sensitivity cases and variable parameters

Case	Parameter
A	Turbine temperature after cool-down ( $T_{cd}$ )
B	Synchronization delay (SD)
C	Ramp up delay (RD)
D	SD+RD
E	Number of available start-up curves

The resulting annual performance of the plant by the different sensitivity studies can be seen on **FIGURE 5a**. In relation to the base case it can be seen that the different changes in turbine performance can lead to improvements of up to 1.88% in the annual electricity production in exchange for 0.4% increase the annual fuel energy. Likewise, the figure also shows how a less optimal turbine operation can lead to up to 2.3% losses in annual power generation. **FIGURE 5b** shows the annual distribution of turbine starts for the base case and the obtained positive results from cases A, D and E. It can be seen that as each case varies a different turbine start-up parameter, the annual distribution varies in a different way: either by the distribution start-types (Case A), the time of the starts (Case D) or both (Case E). Overall it can be seen that the yielded benefits for each case come from a decrease of the annual time in start-up, which translates into more time in nominal operation.

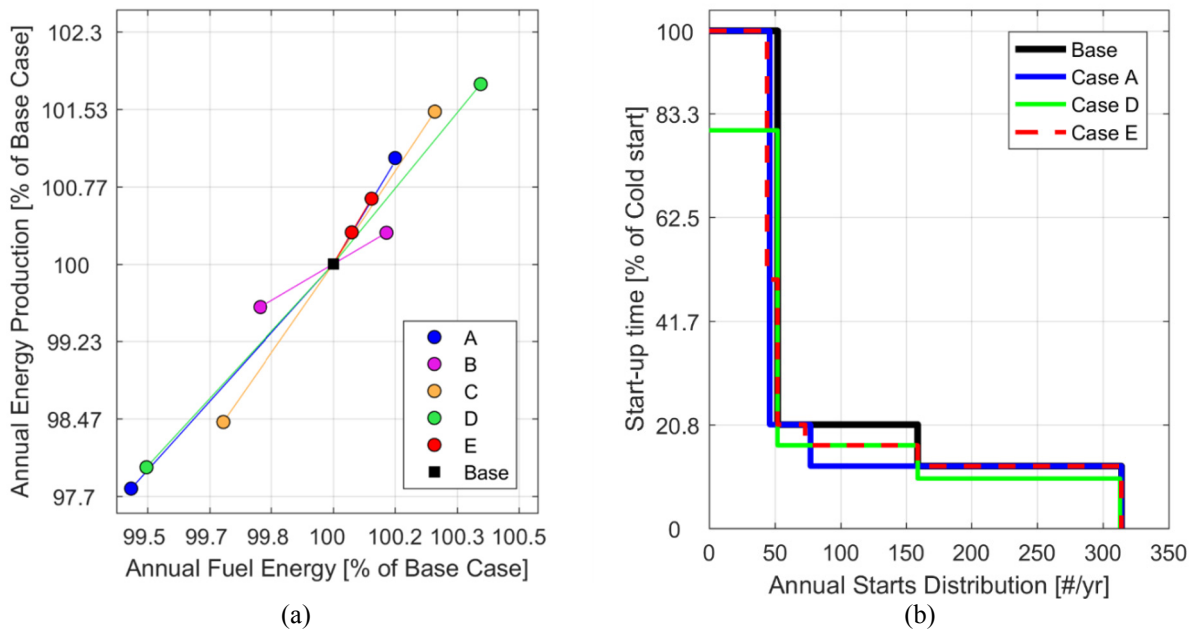

**FIGURE 5.** Annual performance of the plant by the different sensitivity studies: (a) annual yield and fuel energy (b) turbine start-up time and type distribution.



## CONCLUSIONS AND FUTURE WORK

This work focused on analyzing the influence of steam turbine start-up parameters on the overall annual performance of a CSP plant. For this, a PTPP model was used as the base case to compare against different scenarios of improved turbine start-up operation. First, the model was developed with increased detail level on the turbine control strategy during start-up. Then, the model was validated against steady-state and dynamic data from the modeled power plant. Finally, sensitivity studies were carried out for each case and then a comparison was made among the most promising results. From this work the following conclusions are drawn:

- Turbine flexibility at start-up can affect the overall performance of the power plant negatively by up to 2.3% which highlights the importance of pursuing operational improvements on the turbine.
- Likewise, turbine flexibility at start-up was found to increase the annual power plant production by up to 1.88%. This was achieved with an increased fossil fuel consumption of 0.4%
- From the sensitivity studies performed, the most favorable ways of increasing turbine flexibility, once the turbine has been commissioned and installed, were: keeping the turbine warmer during offline periods and decreasing the ramping time of the turbine.

Future work with regards to this study shall include refining of the model against the measured data to be even more accurate in the dynamic behavior. Also, these studies did not include turbine thermal behavior analysis. As such, one important aspect to investigate would be the life time consumption costs that these start-up changes at power plant level would have on component level. Similarly, all the measures in this work were implemented on a one-at-a-time basis in the sensitivity studies. A combination of the measures alongside with the related costs would represent an interesting optimization case. Furthermore, a similar analysis including all economic aspects of the power plant would complete the question on whether the power plant is more profitable through increase turbine flexibility. Finally, other operating strategies for increased flexibility can be investigated based on the model developed on this work. Specifically, with regards to the trade-off of using back-up fossil fuel firing to pre-warm the turbine.

## ACKNOWLEDGEMENTS

This research has been funded by the Swedish Energy Agency, Siemens Industrial Turbomachinery AB, GKN Aerospace and KTH Royal Institute of Technology. Furthermore, the studies performed in this work were done with in collaboration with Shams Power Company, all support and feedback which are gratefully appreciated.

## REFERENCES

- [1] Groupe Reaction Inc (2013), "CSP Parabolic Trough Report 2014: Costs, Performance and Thermal Storage", CSP Today-(FC Business Intelligence), London.
- [2] CSP World (2013), "CSP Facts and Figures", retrieved from [www.csp-world.com](http://www.csp-world.com), (Accessed June 4 2017)
- [3] IRENA, (2012) "Renewable Energy Technologies Cost Analysis Series: Concentrating Solar Power," Tech. Rep. 2/5, IRENA.
- [4] IEA, (2015), Projected Costs of Generating Electricity.
- [5] IRENA (2015), Renewable power generation costs in 2014.
- [6] IRENA, (2016), REmap: Roadmap for a Renewable Energy Future.
- [7] IEA, (2014), Technology Roadmap: Solar Thermal Electricity.
- [8] G. Kolb, C. Ho, T. Mancini, and J. Gary, "Power Tower Technology Roadmap and Cost Reduction Plan," Tech. Rep. April, Sandia National Laboratories, 2011.
- [9] R. Guedez, M. Topel, I. Conde, F. Ferragut, I. Callaba, J. Spelling, Z. Hassar, C. Perez-Segarra, and B. Laumert, A Methodology for Determining Optimum Solar Tower Plant Configurations and Operating Strategies to Maximize Profits Based on Hourly Electricity Market Prices and Tariffs," [Solar Energy Engineering](#), 138(2), (2016).
- [10] Jöcker M, Wikström R, Nyqvist J. Steam Turbine Optimization for Operation in Thermal Solar Power Plants. In: PowerGen Europe Conference. Germany; 2012:1–16.
- [11] J. Spelling, M. Jöcker, A. Martin, "Thermal modeling of a solar steam turbine with a focus on start-up time reduction". [Journal of engineering for gas turbines and power](#). 134(1). (2012)
- [12] M. Topel, M. Genrup, M. Jöcker, J. Spelling, B. Laumert, "Operational improvements for startup time reduction in solar steam turbines". [Journal of Engineering for Gas Turbines and Power](#). 137(4) (2015)

- [13] M. Topel, R. Guedez, F. Ellakany, B. Laumert “Techno-economic study on the implementation of steam turbine concepts for flexible operation on a direct steam generation solar tower power plant”, Proceedings of the international Solar PACES Conference 2016, AIP conference proceedings, Volume 1734.
- [14] M. Topel (2017) Improving Concentrating Solar Power Plant Performance through Steam Turbine Flexibility. Doctoral thesis, KTH Royal Institute of Technology, Stockholm
- [15] M. Topel, B. Laumert Improving Concentrating Solar Power Plant Performance by Increasing Steam Turbine Flexibility at Start-up, *Solar Energy* 165 (2018) 10-18
- [16] J. Spelling, (2013) Hybrid Solar Gas Turbine Power Plants: A Techno-Economic Analysis. Doctoral thesis, KTH Royal Institute of Technology, Stockholm.
- [17] R. Guédez, (2016), A Techno-economic Framework for the Analysis of Concentrating Solar Power Plants with Storage. Doctoral thesis, KTH Royal Institute of Technology, Stockholm.
- [18] National Renewable Energy Laboratories, “Shams 1” [https://www.nrel.gov/csp/solarpaces/project\\_detail.cfm/projectID=69](https://www.nrel.gov/csp/solarpaces/project_detail.cfm/projectID=69) , (Accessed June 4 2017).
- [19] Shams Power Company “Facsheets” <http://shampower.ae/en/the-project/factsheets/overview/> (Accessed June 4 2017)
- [20] Incropera F, Dewitt D. (2007) Fundamentals of Heat and Mass Transfer. New York: Wiley and Sons.
- [21] F. Staine, (1995) “Intégration énergétique des procédés industriels par la méthode du pincement étendue aux facteurs exergetiques”, PhD Thesis #1318, Swiss Federal Technology Institute, Lausanne.
- [22] P. Gilman, N. Blair, M. Mehos, C. Christensen and S. Janzou, (2008) "Solar advisor model user guide for version 2.0," NREL, Colorado.
- [23] F. Lippke, (1995) "Simulation of the Part-Load Behavior of a 30 Mwe SEGS Plant," Sandia National Laboratories, .
- [24] V. A. Dudley, (1994) "SEGS LS-2 Solar Collector. Test Results," Sandia National Laboratories.