



Concrete Plasticity Notes

Nielsen, Leif Otto

Publication date:
2008

Document Version
Publisher's PDF, also known as Version of record

[Link back to DTU Orbit](#)

Citation (APA):
Nielsen, L. O. (2008). *Concrete Plasticity Notes*. Technical University of Denmark, Department of Civil Engineering. DTU Civil Engineering Reports

General rights

Copyright and moral rights for the publications made accessible in the public portal are retained by the authors and/or other copyright owners and it is a condition of accessing publications that users recognise and abide by the legal requirements associated with these rights.

- Users may download and print one copy of any publication from the public portal for the purpose of private study or research.
- You may not further distribute the material or use it for any profit-making activity or commercial gain
- You may freely distribute the URL identifying the publication in the public portal

If you believe that this document breaches copyright please contact us providing details, and we will remove access to the work immediately and investigate your claim.

BYG · DTU

DANMARKS
TEKNISKE
UNIVERSITET



Leif Otto Nielsen

Concrete Plasticity Notes

Undervisningsnotat
BYG · DTU U-087
2008
ISSN 1601 - 8605

CONCRETE PLASTICITY NOTES

Leif Otto Nielsen
16 dec 2008

CONTENTS

1. COULOMB PARAMETER RELATIONS
2. COMMENTS TO PROBLEM 18
3. NUMERICAL DETERMINATION OF YIELD CONDITION FOR A REINFORCED DISK MATERIAL
4. DISSIPATION IN YIELD LINE OF MODIFIED COULOMB MATERIAL
5. RIGID, PERFECTLY PLASTIC MATERIAL
6. ADDITIONS TO CP
7. EQUILIBRIUM STRESSES IN DISK BY MEANS OF CONSTANT STRESS TRIANGLES
8. NUMERICAL DETERMINATION OF YIELD LOAD FOR A REINFORCED DISK
9. ALTERNATIVE RECIPE FOR DISK REINFORCEMENT DESIGN
10. PROBLEMS
 - 1a,3a,6a,10a,16a,23a
 - 101,102,103,104
 - E06lonpr1,2,3
11. ANSWERS TO SOME PROBLEMS
12. EQUIVALENT ORTHOTROPIC REINFORCEMENT IN A SOLID
13. NUMERICAL DETERMINATION OF YIELD CONDITION FOR A REINFORCED SOLID MATERIAL

1. COULOMB PARAMETER RELATIONS

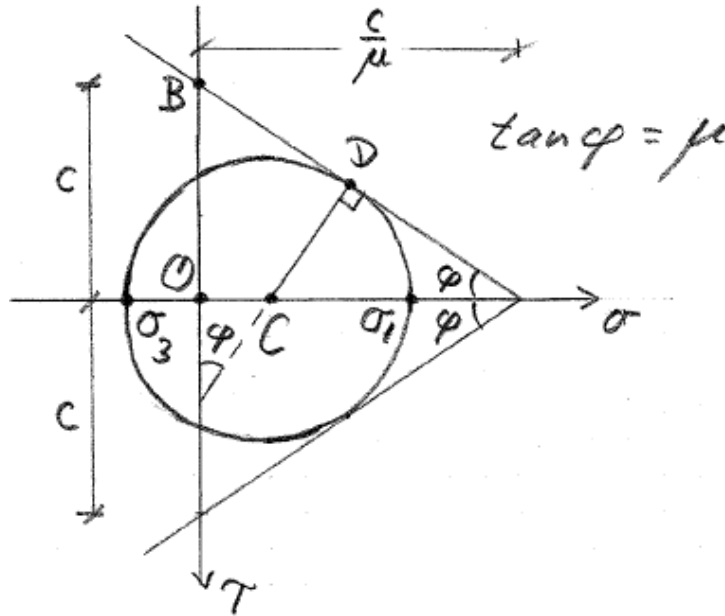

Figure 1.1 Mohr's circle at sliding failure.

To obtain the principal stress form of Coulomb's yield condition, COB is projected on CD giving

$$\frac{1}{2}(\sigma_1 - \sigma_3) = -\frac{1}{2}(\sigma_1 + \sigma_3) \sin \varphi + c \cos \varphi \quad (1.1)$$

(1.1) is rearranged to

$$\frac{1}{2} \sigma_1 (1 + \sin \varphi) - \frac{1}{2} \sigma_3 (1 - \sin \varphi) = c \cos \varphi \quad (1.2)$$

This is multiplied by $1 + \sin \varphi$

$$\frac{1}{2} \sigma_1 (1 + \sin \varphi)^2 - \frac{1}{2} \sigma_3 \cos^2 \varphi = c \cos \varphi (1 + \sin \varphi) \quad (1.3)$$

and is next divided by $\frac{1}{2} \cos^2 \varphi$ giving

$$\sigma_1 \frac{(1 + \sin \varphi)^2}{\cos^2 \varphi} - \sigma_3 = 2c \frac{1 + \sin \varphi}{\cos \varphi} \quad (1.4)$$

Introducing the friction parameter k

$$k = \frac{(1 + \sin \varphi)^2}{\cos^2 \varphi} \quad (1.5)$$

simplifies (1.4) to (1.6)

$$k \sigma_1 - \sigma_3 = 2c \sqrt{k} \quad (1.6)$$

Dividing $\sin^2 \varphi + \cos^2 \varphi = 1$ by $\cos^2 \varphi$ gives $\frac{1}{\cos^2 \varphi} = \tan^2 \varphi + 1$. With this and μ -expression

in CP, fig 2.1.2 $\tan \varphi = \mu$ is obtained from (1.5)

$$k = \frac{(1 + \sin \varphi)^2}{\cos^2 \varphi} = \left(\frac{1}{\cos \varphi} + \tan \varphi \right)^2 = (\tan \varphi + \sqrt{1 + \tan^2 \varphi})^2 = (\mu + \sqrt{1 + \mu^2})^2 \quad (1.7)$$

Expanding the μ -expression in (1.7) gives

$$k - 1 = 2\mu\sqrt{k} \quad (1.7a)$$

Dividing (1.2) by $\frac{1}{2}(1 - \sin \varphi)$ gives

$$\sigma_1 \frac{1 + \sin \varphi}{1 - \sin \varphi} - \sigma_3 = 2c \frac{\cos \varphi}{1 - \sin \varphi} \quad (1.8)$$

Comparing this with (1.6) gives two expressions for k

$$k = \frac{1 + \sin \varphi}{1 - \sin \varphi} = \left(\frac{\cos \varphi}{1 - \sin \varphi} \right)^2 \quad (1.9)$$

From (1.9¹) is obtained

$$k - 1 = \frac{1 + \sin \varphi}{1 - \sin \varphi} - 1 = \frac{1 + \sin \varphi - (1 - \sin \varphi)}{1 - \sin \varphi}$$

i.e.

$$k - 1 = \frac{2 \sin \varphi}{1 - \sin \varphi} \quad (1.10)$$

In the same way is obtained from (1.9¹)

$$k + 1 = \frac{2}{1 - \sin \varphi} \quad (1.11)$$

and

$$1 - \sin \varphi = \frac{2}{k + 1} \quad (1.12)$$

Multiplying (1.9) with (1.12) gives

$$1 + \sin \varphi = \frac{2k}{k + 1} \quad (1.13)$$

Rearranging (1.12) gives

$$\sin \varphi = \frac{k - 1}{k + 1} \quad (1.14)$$

(1.9²) and (1.12) gives

$$\cos \varphi = \sqrt{k}(1 - \sin \varphi) = \frac{2\sqrt{k}}{k + 1} \quad (1.15)$$

(1.14-15) gives

$$\tan \varphi = \frac{k - 1}{2\sqrt{k}} \quad (1.16)$$

From the f_c -expression CP(2.1.9) is obtained using (1.15) respectively (1.9²)

$$f_c = 2c\sqrt{k} = c(k + 1)\cos \varphi = c \frac{2\cos \varphi}{1 - \sin \varphi} \quad (1.17)$$

With the trigonometric formulas

$$\frac{\sin x \pm \sin y}{\cos x + \cos y} = \tan \frac{1}{2}(x \pm y) \quad \frac{\sin x \pm \sin y}{\cos x - \cos y} = -\cot \frac{1}{2}(x \mp y) \quad (1.18)$$

where x, y are arbitrary angles a set of half friction angle formulas are easily obtained. (1.18)

with $x = \pi/2, y = \varphi$ in the first formula and $y = -\varphi$ in the second formula gives

$$\frac{1 \pm \sin \varphi}{0 + \cos \varphi} = \tan(45^\circ \pm \frac{\varphi}{2}) \quad \frac{1 \mp \sin \varphi}{0 - \cos \varphi} = -\cot(45^\circ \pm \frac{\varphi}{2})$$

and then the ratios

$$\frac{1 + \sin \varphi}{1 - \sin \varphi} = \tan^2\left(45^\circ + \frac{\varphi}{2}\right) \qquad \frac{1 - \sin \varphi}{1 + \sin \varphi} = \tan^2\left(45^\circ - \frac{\varphi}{2}\right) \qquad (1.19)$$

Inserting (1.19) in (1.9¹) gives

$$k = \tan^2\left(45^\circ + \frac{\varphi}{2}\right) \qquad \frac{1}{k} = \tan^2\left(45^\circ - \frac{\varphi}{2}\right) \qquad (1.20)$$

i.e.

$$\cos^2\left(45^\circ + \frac{\varphi}{2}\right) = \frac{1}{k+1} \qquad \cos^2\left(45^\circ - \frac{\varphi}{2}\right) = \frac{k}{k+1} \qquad (1.21)$$

$$\sin^2\left(45^\circ + \frac{\varphi}{2}\right) = \frac{k}{k+1} \qquad \sin^2\left(45^\circ - \frac{\varphi}{2}\right) = \frac{1}{k+1} \qquad (1.22)$$

■

2. COMMENTS TO PROBLEM 18

Without local strengthening of a lateral loaded plate near a column support, a localized yield line pattern at the column is often essential. In the actual case two possibilities are shown on the figure.

For case b is obtained the upper bound for the yield load $p_Y^+ = 13.7 \frac{m_p}{a^2}$, i.e. a smaller value than the best value from CPans, problem 18.

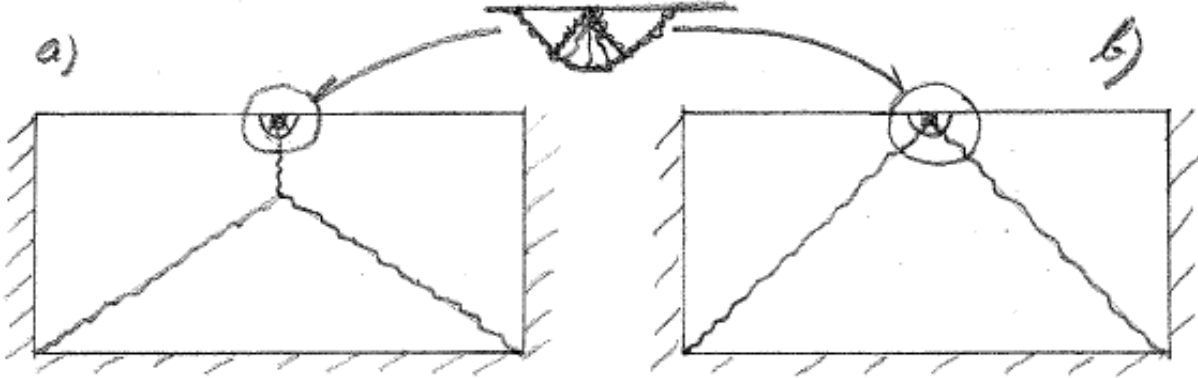

Figure 1: Yield line patterns with localization (CP, p505, fig 6.5.9p) at the column support.

However, an expansion of the local yield line pattern to a non-local yield line pattern is more

dangerous here. A smaller upper bound $p_Y^+ = 12.2 \frac{m_p}{a^2}$ is obtained for the yield line pattern

indicated on figure 2 (positive yield line solid, negative yield line dashed). A lower bound based on

a moderate number of equilibrium elements with moment degree 2 or higher has been determined to

$$p_Y^- = 10.7 \frac{m_p}{a^2}.$$

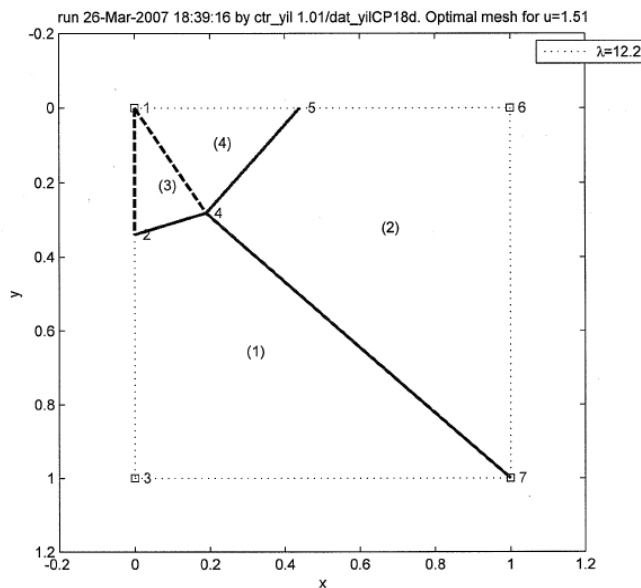

Figure 2: Yield line pattern for half-plate non-local at the column support in node 1.

■

3. NUMERICAL DETERMINATION OF YIELD CONDITION FOR A REINFORCED DISK MATERIAL

The determination of the yield condition is as in CP, sec.2.2.2 based on the lower bound theorem. The notation from CP is used as far as possible.

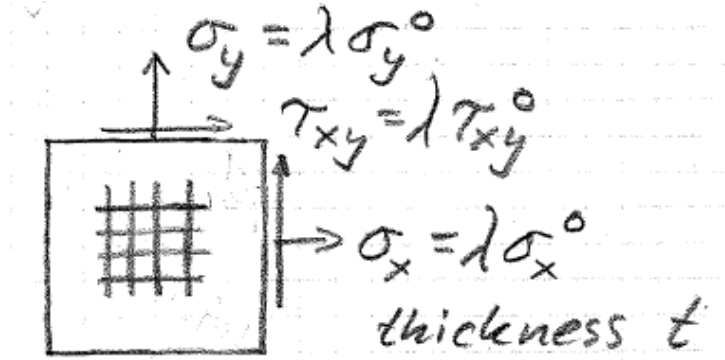

Figure 1: Reinforced disk.

The stresses on the disk boundary, see Figure 1, are written as $\lambda(\sigma_x^0, \sigma_y^0, \tau_{xy}^0)$, where λ is the load factor. The stress in a rebar in the x-direction is called σ_{sx} and for a rebar in the y-direction is used σ_{sy} .

The stress equilibrium on the disk boundary gives

$$\lambda \sigma_x^0 = \sigma_{sx} \frac{A_{sx}}{t} + \sigma_{cx} \quad \lambda \sigma_y^0 = \sigma_{sy} \frac{A_{sy}}{t} + \sigma_{cy} \quad \lambda \tau_{xy}^0 = \tau_{cxy} \quad (1)$$

The yield conditions for both concrete and rebars must not be violated

$$-f_c \leq \sigma_{c1} \leq 0 \quad -f_c \leq \sigma_{c2} \leq 0 \quad (2)$$

$$-f_Y \leq \sigma_{sx} \leq f_Y \quad -f_Y \leq \sigma_{sy} \leq f_Y \quad (3)$$

The relation between the stress components and the principal stresses in the concrete is

$$\left. \begin{array}{l} \sigma_{c1} \\ \sigma_{c2} \end{array} \right\} = \frac{1}{2}(\sigma_{cx} + \sigma_{cy}) \pm \sqrt{\left(\frac{1}{2}(\sigma_{cx} - \sigma_{cy})\right)^2 + \tau_{cxy}^2} \quad (4)$$

Combining (4) and (2) means that the greatest principal stress must be ≤ 0 and that the smallest must be $\geq -f_c$, i.e.

$$\frac{1}{2}(\sigma_{cx} + \sigma_{cy}) + \sqrt{\left(\frac{1}{2}(\sigma_{cx} - \sigma_{cy})\right)^2 + \tau_{cxy}^2} \leq 0 \quad (5)$$

$$\frac{1}{2}(\sigma_{cx} + \sigma_{cy}) - \sqrt{\left(\frac{1}{2}(\sigma_{cx} - \sigma_{cy})\right)^2 + \tau_{cxy}^2} \geq -f_c \quad (6)$$

Given $(\sigma_x^0, \sigma_y^0, \tau_{xy}^0)$, a solution $(\sigma_{sx}, \sigma_{sy}, \sigma_{cx}, \sigma_{cy}, \tau_{cxy}, \lambda)$ to (1,3,5,6) is obviously a lower bound solution. Maximizing the load parameter must give the yield load λ_Y

$$\max \lambda = \lambda_Y \quad (7)$$

The conditions (1,3,5,6,7) define a problem in non-linear programming. It is non-linear because not all conditions are linear ((5,6) are non-linear). If (5,6) are linearized a problem in linear programming is obtained.

The linearization of (5) is now described. Introducing the auxiliary variables σ_m and σ_d defined by

$$\sigma_m = -\frac{1}{2}(\sigma_{cx} + \sigma_{cy}) \quad \sigma_d = \frac{1}{2}(\sigma_{cx} - \sigma_{cy}) \quad (8)$$

simplifies (5) to

$$\sqrt{\sigma_d^2 + \tau_{cxy}^2} \leq \sigma_m \quad (9)$$

A linearization of (9), which is a cone for $\sigma_m \geq 0$, see Figure 2, is easily made. The cone is approximated by nc planes as accurately as wanted. Plane j ($j=1,2,\dots,nc$) of these planes contains the 3 points $A:(0,0,0)$, $j-1:(\cos((j-1)\Delta\theta), \sin((j-1)\Delta\theta), 1)$ and $j:(\cos j\Delta\theta, \sin j\Delta\theta, 1)$, where $\Delta\theta = 2\pi/nc$. An outward directed plane normal \mathbf{n} is determined by $\mathbf{n} = \overrightarrow{Aj} \times \overrightarrow{Aj-1}$ and then is obtained the plane equation $(\sigma_d, \tau_{cxy}, \sigma_m) \cdot \mathbf{n} = 0$..

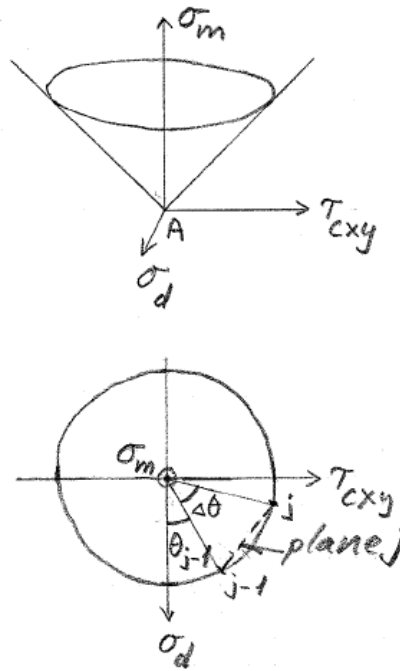

Figure 2: Linearization of cone.

Introducing the auxiliary variable σ_a defined by

$$\sigma_a + \sigma_m = f_c \quad (10)$$

simplifies (6) to

$$\sqrt{\sigma_d^2 + \tau_{cxy}^2} \leq \sigma_a \quad (11)$$

i.e. the form (9). (11) is then linearized analogously to (9).

4. DISSIPATION IN YIELD LINE OF MODIFIED COULOMB MATERIAL

The notation from CP,p160-161,165-166 is used as far as possible and will not be redefined.

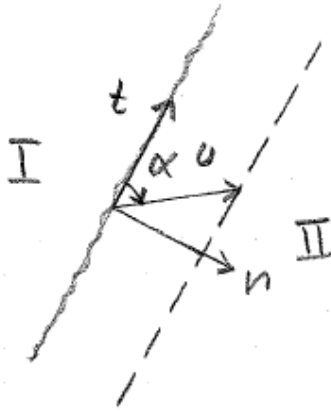

Figure 1: Yield line.

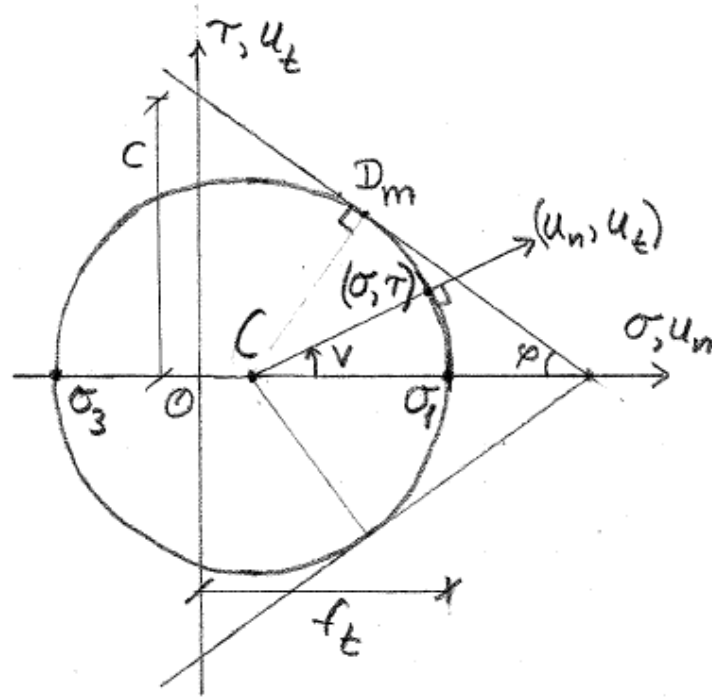

Figure 2: Modified Coulomb material.

A yield line is shown on Figure 1 and we have the relations concerning the displacements in the yield line

$$u_n = u \sin \alpha \quad u_t = u \cos \alpha \quad \tan \alpha = \frac{u_n}{u_t} \quad (1)$$

The curved part of the modified Coulomb yield condition is considered Figure 2, i.e. $|\nu| < \frac{\pi}{2} - \varphi$. For a stress point (σ, τ) on this part, the flow rule (normality condition) determines the ratio between the displacements in the yield line (u_n, u_t)

$$\tan \nu = \frac{u_t}{u_n} \quad (2)$$

Comparing (1) and (2) gives

$$\nu = \frac{\pi}{2} - \alpha \quad (3)$$

i.e. the curved part of the modified Coulomb yield condition is active if

$$\varphi < \alpha < \pi - \varphi \quad (4)$$

From Figure 2 is seen

$$(\sigma, \tau) = \left(\frac{\sigma_1 + \sigma_3}{2}, 0 \right) + \frac{\sigma_1 - \sigma_3}{2} (\cos \nu, \sin \nu) \quad (5)$$

The internal work per length unit of the yield line (and one length unit perpendicular to the Figure 1 plane) is obviously

$$W = \sigma u_n + \tau u_t \quad (6)$$

Inserting (5) and (1) in this gives

$$W = \left(\frac{\sigma_1 + \sigma_3}{2} + \frac{\sigma_1 - \sigma_3}{2} \cos v \right) u \sin \alpha + \frac{\sigma_1 - \sigma_3}{2} (\sin v) u \cos \alpha$$

which is further reduced by (3)

$$W = \frac{\sigma_1 + \sigma_3}{2} u \sin \alpha + \frac{\sigma_1 - \sigma_3}{2} u \quad (7)$$

With the σ_1, σ_3 -circle through the points D_m and $(\sigma, \tau) = (f_t, 0)$, is obtained $\sigma_1 = f_t$ and then $kf_t - \sigma_3 = f_c$ giving $\sigma_3 = kf_t - f_c$. With these expressions for σ_1, σ_3 we get

$$\frac{\sigma_1 + \sigma_3}{2} = \frac{1}{2}(f_t + kf_t - f_c) = -\frac{1}{2}f_c \left(1 - \frac{f_t}{f_c}(k+1)\right) \equiv -\frac{1}{2}f_c m \quad (8)$$

where last equal sign defines m . Moreover we get

$$\frac{\sigma_1 - \sigma_3}{2} = \frac{1}{2}(f_t - kf_t + f_c) = \frac{1}{2}f_c \left(1 - \frac{f_t}{f_c}(k-1)\right) \equiv \frac{1}{2}f_c l \quad (9)$$

where last equal sign defines l .

Now (7) with (8-9) inserted gives

$$W = \frac{1}{2}f_c u (-m \sin \alpha + l) \quad (10)$$

(10,8,9) are identical with CP(3.4.86,85,84) used with thickness $b = 1$.

In fact (10) also determines the dissipation outside the curved part of the modified Coulomb yield condition. Obviously the dissipation in point D_m can be used. Using (10) for $\alpha \rightarrow \varphi_+$ or $\alpha \rightarrow \pi - \varphi_-$ gives the limit value

$$W = \frac{1}{2}f_c u \left(-\left(1 - \frac{f_t}{f_c}(k+1)\right) \sin \varphi + 1 - \frac{f_t}{f_c}(k-1) \right)$$

and with CPnotes,(1.10-11)

$$W = \frac{1}{2}f_c u \left(1 - \sin \varphi + \frac{f_t}{f_c} \left(\frac{2}{1 - \sin \varphi} \sin \varphi - \frac{2 \sin \varphi}{1 - \sin \varphi} \right) \right) = \frac{1}{2}f_c u (1 - \sin \varphi) \quad (11)$$

Inserting CPnotes,(1.17) in (11) gives

$$W = cu \cos \varphi \quad (12)$$

identical with CP(3.4.77) used with thickness $b = 1$.

■

5. RIGID, PERFECTLY PLASTIC MATERIAL

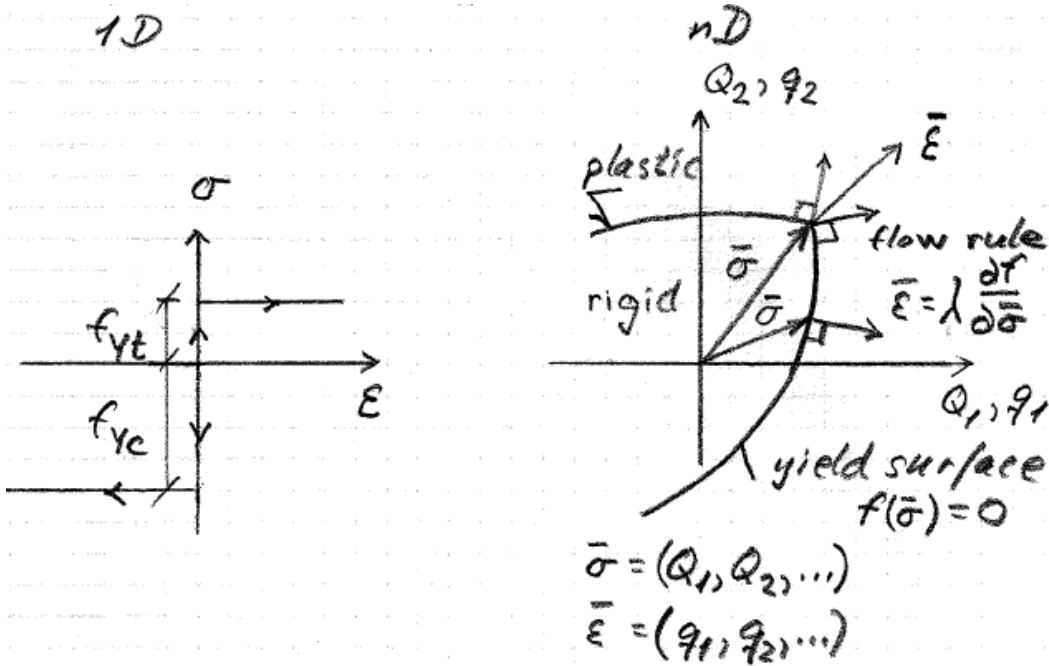

Lower bound theorem

First, we show that if the load has such a magnitude that it is possible to find a stress distribution corresponding to stresses within the yield surface and satisfying the equilibrium conditions and the statical boundary conditions for the actual load, then this load will not be able to cause collapse of the body. A stress distribution such as this is denoted a safe and statically admissible stress distribution.

Upper bound theorem

A geometrically possible displacement and strain field satisfies the structural continuity and support conditions and the flow rule. For such field the equation

$$\text{external work} = \text{internal work} \Rightarrow$$

$$\text{load} \geq \text{yield load}$$

i.e. the load cannot in general be carried by the structure.

6. ADDITIONS TO CP

p123, line4fb: If $\sigma_y < 0$, reinforcement... -> Reinforcement...

p124, line6ft: ...see below -> ...see below or see (2.2.49)

■

7. EQUILIBRIUM STRESSES IN DISK BY MEANS OF CONSTANT STRESS TRIANGLES

In order to obtain a lower bound solution for a rigid-plastic reinforced disk, an equilibrium stress field in the disk is needed. The disk considered here is only loaded by boundary load. How to obtain equilibrium stresses is explained by example. The disk shown in Figure 1 is considered. The notation defined in CP is used as far as possible.

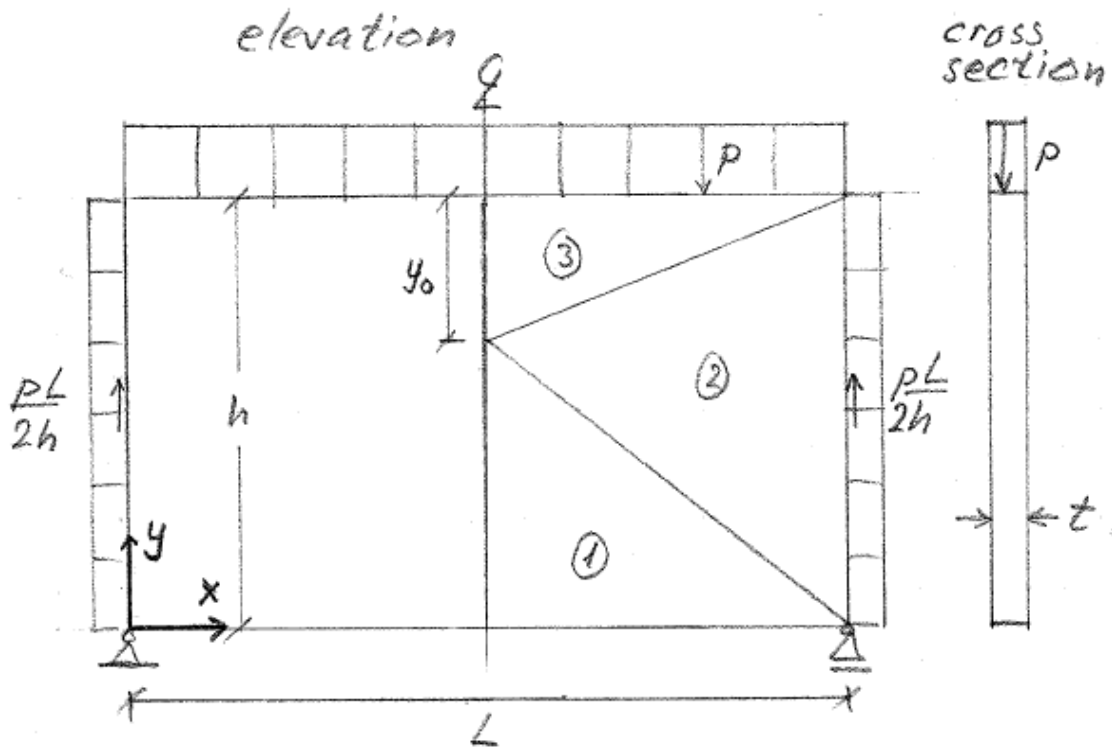

Figure 1: Disk with triangle mesh.

Utilizing symmetry the half disk is partitioned in three triangles 1,2,3 as shown on Figure 1. In each triangle is used a yet unknown constant stress field $\sigma_x, \sigma_y, \tau_{xy}$, i.e. the equilibrium conditions are satisfied inside each triangle. With these constant triangle stresses, the stresses on the triangle boundaries must be constant too, i.e. they give a resultant force vector F_x, F_y in the midpoint of each triangle edge. In Figure 2a is shown the forces from the boundary and symmetry conditions.

Next the equilibrium conditions are utilized for each triangle (projection x, projection y and moment) and between neighboring triangles (projection x, projection y) to determine as far as possible the still unknown forces on the triangle edges. In the actual example these are statically determined.

For triangle 1 is introduced the notation $\sigma_t = \sigma_x$ and the projection equations determine the unknown forces on the edge 1-2 as shown on Figure 2b. The moment equation is fulfilled.

For triangle 3 is introduced the notation $\sigma_c = -\sigma_x$ and the projection equations determine the unknown forces on the edge 3-2 as shown on Figure 2b. The moment equation is fulfilled.

Triangle 2 is now loaded by forces from triangle 1 and 3 as shown on Figure 2b. For triangle 2 the y-projection equation is fulfilled, while the x-projection equation and the moment equation (here about the midpoint of edge 2-3) give

$$\sigma_t(h - y_0)t = \sigma_c y_0 t \quad (1)$$

$$\frac{pL}{2} \frac{L}{4} t = \sigma_t(h - y_0) \frac{h}{2} t \quad (2)$$

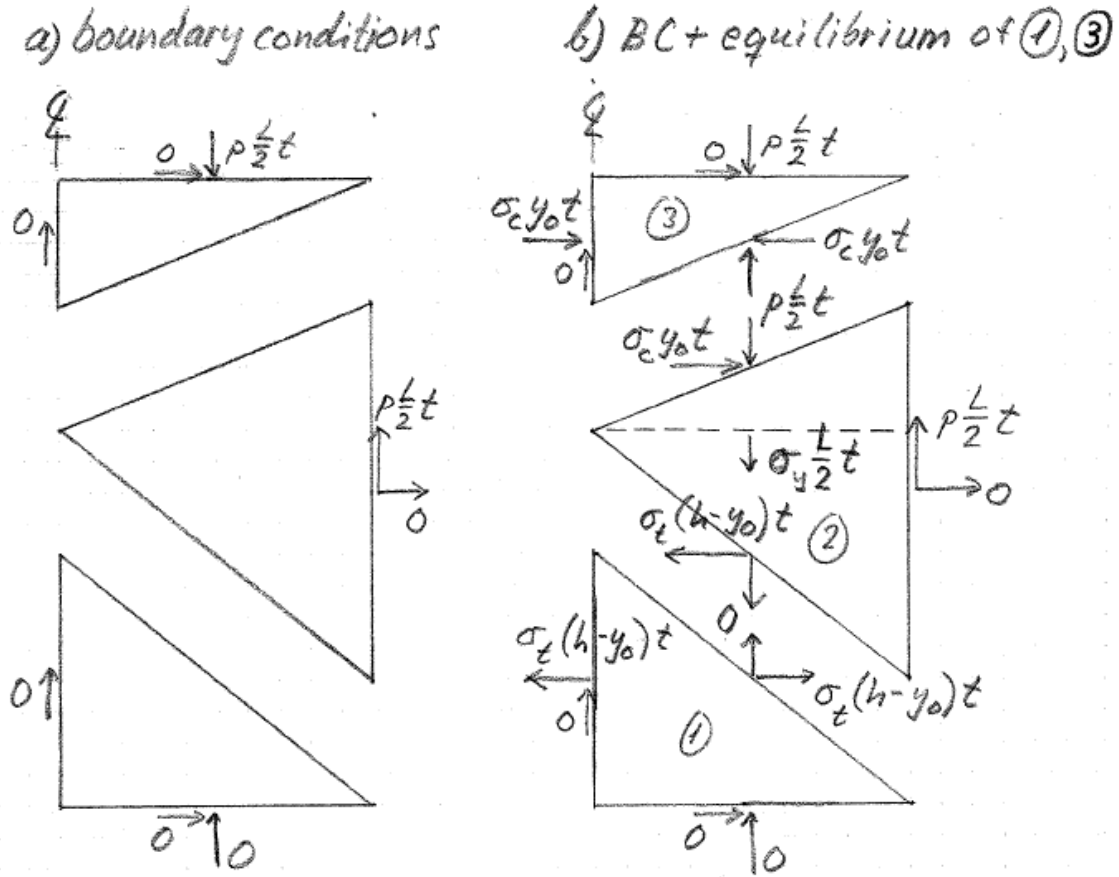

Figure 2: Forces on triangle edges.

Most of the stresses in the three triangles are determined by uniform distribution of the forces on the axis parallel triangle edges. However, σ_y in triangle 2 cannot be determined this way so a cut is made in triangle 2 as shown in Figure 2b and y-projection then gives $\sigma_y \frac{L}{2} t = -p \frac{L}{2} t + p \frac{L}{2} t \frac{y_0}{h}$ in triangle 2. In total we have

$$1: (\sigma_x, \sigma_y, \tau_{xy}) = (\sigma_t, 0, 0) \quad (3)$$

$$2: (\sigma_x, \sigma_y, \tau_{xy}) = (0, -p + \frac{py_0}{h}, \frac{pL}{2h}) \quad (4)$$

$$3: (\sigma_x, \sigma_y, \tau_{xy}) = (-\sigma_c, -p, 0) \quad (5)$$

■

8. NUMERICAL DETERMINATION OF YIELD LOAD FOR A REINFORCED DISK

Optimization formulation based on constant stress triangles. Notation as in CP with the extension that the rebar yield stress f_Y may be given different values in the x, y -direction and in tension respectively compression. With constant stresses in each triangle Fig. 1, the interior equilibrium is satisfied in each triangle for zero body loads.

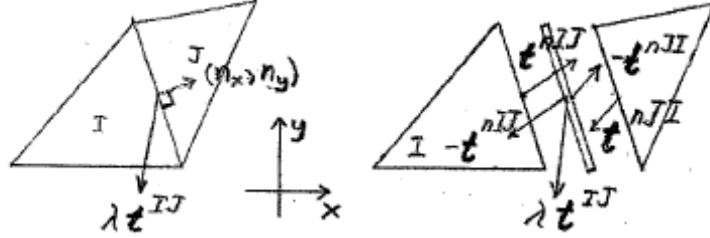

Fig. 1.

Equilibrium for each intertriangle edge Fig. 1 with load shape \mathbf{t}^{IJ} and load factor λ

$$-\mathbf{t}^{nIJ} - \mathbf{t}^{nJI} + \lambda \mathbf{t}^{IJ} = 0 \quad (8.1)$$

(triangle boundary edge included: triangle J vanish and then $-\mathbf{t}^{nJI} = \text{reactions}$ (0 if none)).

Stress vector (tractions) – stress tensor relation in index notation and with summation convention:

$$t_i^{(n)} = \sigma_{ji} n_j \quad (8.2)$$

(8.1) and (8.2) combined with $\sigma_{ji} = \sigma_{ij} \Rightarrow$

$$\begin{aligned} (\sigma_x^I - \sigma_x^J) n_x + (\tau_{xy}^I - \tau_{xy}^J) n_y &= \lambda t_x^{IJ} \\ (\tau_{xy}^I - \tau_{xy}^J) n_x + (\sigma_y^I - \sigma_y^J) n_y &= \lambda t_y^{IJ} \end{aligned} \quad (8.3)$$

In each triangle:

$$\sigma_x = \sigma_{sx} \frac{A_{sx}}{t} + \sigma_{cx} \quad \sigma_y = \sigma_{sy} \frac{A_{sy}}{t} + \sigma_{cy} \quad \tau_{xy} = \tau_{cxy} \quad (8.4)$$

$$-f_Y \leq \sigma_{sx} \leq f_Y \quad -f_Y \leq \sigma_{sy} \leq f_Y \quad (8.5)$$

$$\frac{1}{2}(\sigma_{cx} + \sigma_{cy}) + \sqrt{\left(\frac{1}{2}(\sigma_{cx} - \sigma_{cy})\right)^2 + \tau_{cxy}^2} \leq 0 \quad (8.6)$$

$$\frac{1}{2}(\sigma_{cx} + \sigma_{cy}) - \sqrt{\left(\frac{1}{2}(\sigma_{cx} - \sigma_{cy})\right)^2 + \tau_{cxy}^2} \geq -f_c$$

Lower bound theorem \Rightarrow

$$\max \lambda \leq \lambda_Y \quad (8.7)$$

Utilizing (8.3) for all element edges in the structure to be analyzed, (8.4)-(8.6) for all elements and (8.7) gives a nonlinear optimization (programming) problem, which is convex. It can be handled as a second order cone optimization problem, which can be solved by Mosek (see www.mosek.com).

If (8.6) is linearized a linear optimization problem is obtained and the simplex method can be used for its solution.

To get a load factor λ close to the yield load λ_Y , the meshing with constant stress triangles of the structure to be analyzed must allow a stress distribution in the meshed structure close to one of the stress distributions, which can exist in the original structure at the yield load.

9. ALTERNATIVE RECIPE FOR DISK REINFORCEMENT DESIGN

Compute

$$f_{tx} = \sigma_x + |\tau_{xy}| \quad f_{ty} = \sigma_y + |\tau_{xy}| \quad \sigma_c = 2|\tau_{xy}| \quad (1)$$

Ok if $f_{tx} \geq 0$ and $f_{ty} \geq 0$. If not compute

$$d = \sigma_x \sigma_y - \tau_{xy}^2 \quad (2)$$

If $d \geq 0$ no reinforcement is needed and σ_c is determined by the smallest principal stress, i.e.

$$f_{tx} = 0 \quad f_{ty} = 0 \quad \sigma_c = \left| \frac{1}{2}(\sigma_x + \sigma_y) - \sqrt{\frac{1}{4}(\sigma_x - \sigma_y)^2 + \tau_{xy}^2} \right| \quad (3)$$

Otherwise ($d < 0$) the negative value of f_{tx} or f_{ty} is changed to zero and the relevant formula set below is used

$$f_{tx} = 0 \quad f_{ty} = \sigma_y + \frac{\tau_{xy}^2}{|\sigma_x|} \quad \sigma_c = |\sigma_x| + \frac{\tau_{xy}^2}{|\sigma_x|} \quad (4)$$

$$f_{tx} = \sigma_x + \frac{\tau_{xy}^2}{|\sigma_y|} \quad f_{ty} = 0 \quad \sigma_c = |\sigma_y| + \frac{\tau_{xy}^2}{|\sigma_y|} \quad (5)$$

■

10. PROBLEMS

Problem 16a compared with problem 16 is modified such that the answers to problem 16 are relevant also for problem 16a. This principle has been followed for all problems with a number followed by 'a'.

Problems with numbers above 100 are not found in CPpr and CPans.

Problem 1a

Modifications compared with CPpr, problem 1: Plane stress or plane strain can be considered (depends on the bar thickness). The yield planes are perpendicular to the figure plane. Moreover the question has been detailed.

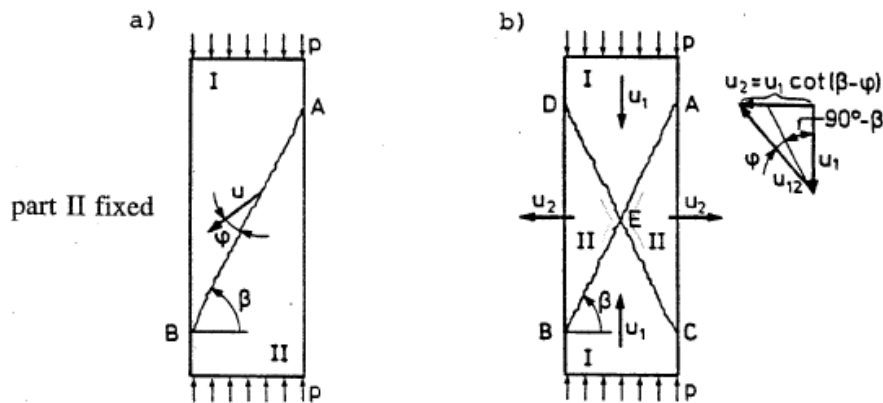

Given is a prismatic straight cut off bar of a Coulomb material with the cohesion c and the angle of friction ϕ subjected to a uniformly distributed pressure p at the ends.

Consider two geometrically possible yield patterns, having the yield planes as shown in the figure (cf. Limit Analysis and Concrete Plasticity § 3.6.1.)

Case a.

Question 1: Determine the internal work in the yield line pattern using the σ, τ form of the Coulomb yield condition.

Question 2: Determine an upper bound p_Y^+ for the yield load p_Y of p .

Question 3: Optimise the upper bound solution in regard to the yield line pattern. Show that the obtained value equals the compressive strength of the Coulomb material and specify the value of angle β for the friction parameter value $k = 4$ (typical value for concrete).

Case b.

Question 4: Determine the ratio between u_1 and u_2 using the flow rule.

Question 5: Determine an upper bound for the yield load, optimise it and compare it with the value obtained in case a.

Problem 3a

Modifications compared with CPpr, problem 3: The disk thickness is t and $\alpha = \frac{\pi}{2}$. Moreover the question has been modified.

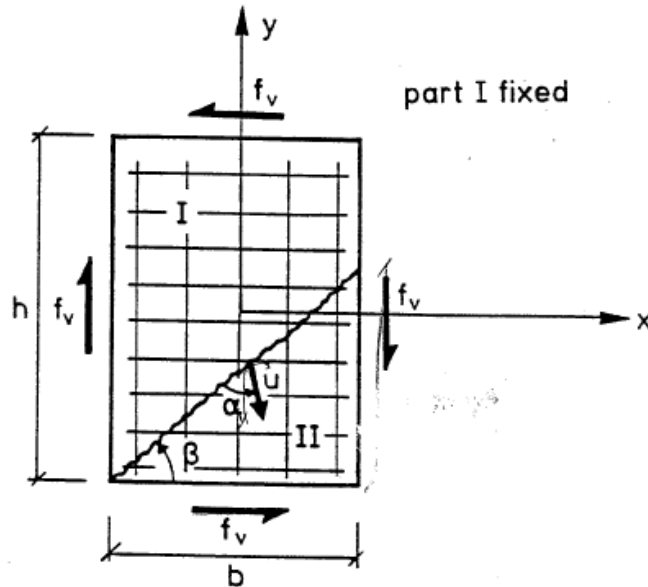

Given is a rectangular concrete disk (bh) subjected to pure shear corresponding to the shear stress f_v . The disk is reinforced in two directions x and y at right angles to each other, corresponding to the reinforcement degrees Φ_x and Φ_y respectively. It is assumed that $\Phi_x + \Phi_y < 1$. The shear stress f_v acts at sections perpendicular to the direction of the reinforcement. A geometrically possible yield pattern with a yield line as shown in the figure is considered.

The concrete is a modified Coulomb material, having a tensile strength equal to zero.

Question 1: Determine, by means of the work equation, an upper bound for f_v .

Question 2: Minimize f_v and compare the result with (2.2.20) in CP. Has the yield load been determined?

Problem 6a

Modifications compared with CPpr, problem 6: The first question has been detailed.

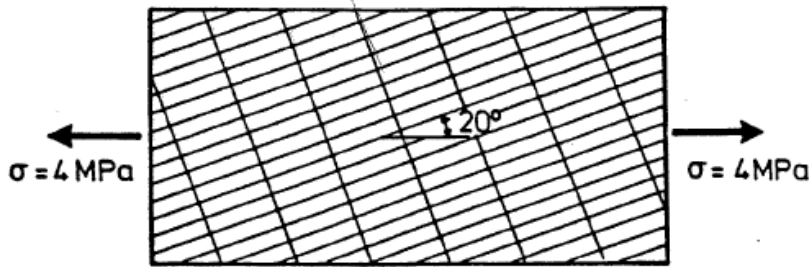

A weightless, rectangular concrete disk, having a thickness of $t = 150 \text{ mm}$, is reinforced in 2 directions at right angles to each other. Along 2 opposite sides the disk is subjected to uniaxial tension, corresponding to a stress of $\sigma = 4 \text{ MPa}$. One direction of the reinforcement forms an angle of 20° with the direction of the applied tensile stress, see the figure. The reinforcing bars are ribbed bars having a design yield stress of $f_{yd} = 400 \text{ MPa}$. The diameter of the reinforcement is 8 mm .

Question 0: Determine the stresses in a coordinate system with axes in the reinforcement directions.

Question 1: Determine the distance between the reinforcing bars, when they are placed in 2 layers.

Question 2: Determine the necessary compressive design strength of the concrete f_{cd} when the effectiveness factor is $\nu = 0.6$.

Question 3: Show by a simplified sketch, the detailing of the reinforcement along the edges.

Problem 10a

Modifications compared with CPpr, problem 10: Question 0 has been inserted.

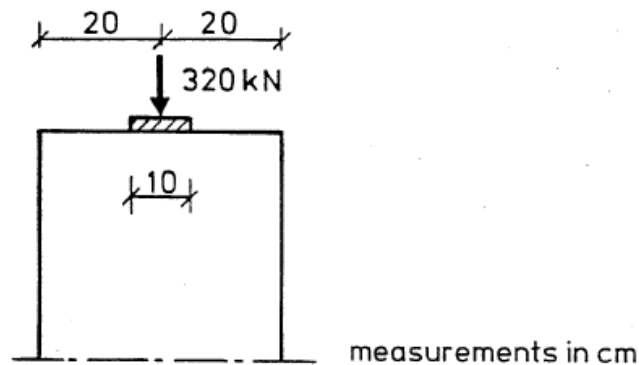

A column has a rectangular cross-section of $200 \times 400 \text{ mm}^2$. A line load with a resultant of 320 kN acts at the top of the column in the direction of the column. The line load is uniformly distributed over the width of the column. The bearing surface is 100 mm wide. It is reinforced by 2-legs stirrups of mild steel with a design yield stress of $f_{yd} = 171.5 \text{ MPa}$ or by Tencor steel with $f_{yd} = 400 \text{ MPa}$ for diameters $\leq 8 \text{ mm}$ and $f_{yd} = 371.4 \text{ MPa}$ for larger diameters. The effective compressive design strength of the concrete is $\nu f_{cd} = 16.7 \text{ MPa}$.

Question 0:

- Based on a constant stress triangle mesh is wanted a set of equilibrium forces on the triangle edges (in agreement to CP, p358 uniform normal stress distribution should be assumed on the column cross section in a depth below the line load equal to the relevant column side length (here 40 cm)).
- Determine the necessary reinforcement area in the symmetry plane to carry the tension (result as in CPans, pr10, q1).
- Determine the compression zone depth in the symmetry plane (result as in CPans, pr10, q1).

Question 1: Determine the reinforcement at the top of the column, transverse to the ~~direction of the force~~ *line load plane.*

Question 2: What additional reinforcement must be provided at the top of the column, if the line load has a transverse component of 64 kN.

Problem 16a

Modifications compared with CPpr, problem 16: The questions have been detailed and the figure corrected.

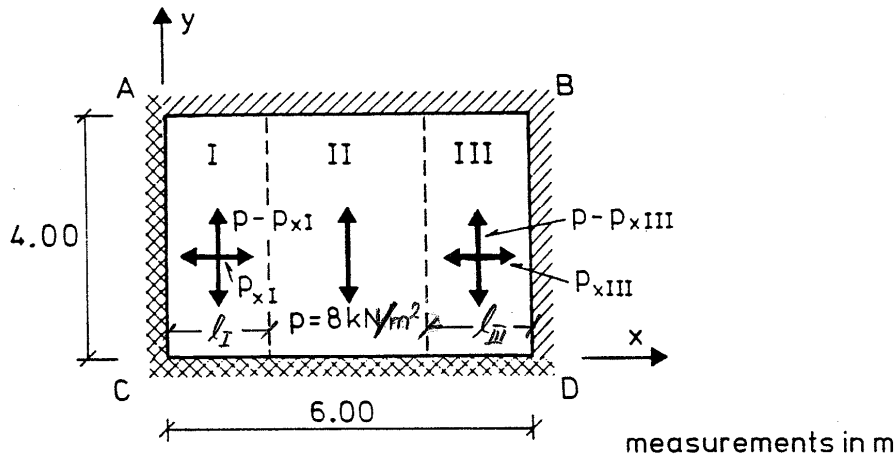

A horizontal, rectangular slab ABCD has the spans shown in the figure. The slab is fixed along the sides AC and CD, and simply supported along the sides AB and BD. Along the fixed sides, the yield moment is set to 0.5 times the positive yield moment (yielding of bottom reinforcement).

The load on the slab is $p = 8 \text{ kN/m}^2$. The slab is reinforced in both the x - and y -directions. A minimum of reinforcement, calculated to correspond to a yield moment of 8 kNm/m , is provided at the lower face in the x - direction. In the same way, a minimum reinforcement is provided at the lower face in the y - direction, in the areas I and III.

The slab is calculated by means of the strip method, being divided into 3 areas, I, II and III, as shown in the figure. The extent of the areas I and III is chosen, so that the minimum reinforcement is utilized fully, which occurs when the load is distributed as shown in the figure.

Question 1: Determine $p - p_{xI}$ utilizing CPans, pr13.

Question 2: Determine $p - p_{xIII}$.

Question 3: Determine l_I and l_{III} considering a strip in the x -direction.

Question 4: Determine the necessary yield moment in the y -direction in area II.

Problem 23a

Modifications compared with CPpr, problem 23: The figure and the question have been modified.

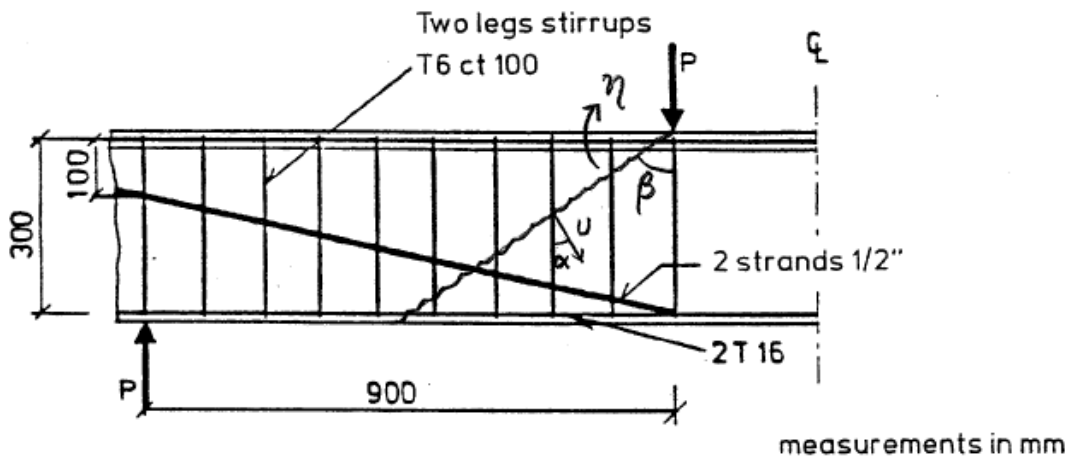

The distance between the tensile and compressive stringers in a horizontal stringer beam is $h = 300$ mm. The beam is simply supported and 2 point loads P are applied symmetrically. The shear span is 900 mm. The width of the web of the beam is 180 mm. The longitudinal reinforcement consists of 2 T16 mm (Tentor steel) with a yield stress of 560 MPa, uncurtailed throughout the lower face of the beam, and 2 no. 1/2" strands (total area 250 mm^2) with a yield stress of 1800 MPa, bent upwards at the place of the point loads and passed rectilinearly to the end of the beam in such a way that the strands are located at a distance of 100 mm from the compressive stringer at the support. In addition, the beam is reinforced by vertical 2-legs stirrups T6 mm ct 100 mm. The stirrups have a yield stress of 520 MPa. The concrete is considered to be a modified Coulomb material having a compressive strength of $f_c = 37.5$ MPa and the tensile strength equal to zero. The effectiveness factor $\nu = 0.8$.

In answering the following question, characteristic values must be applied, i.e. no partial safety factors are introduced for loads and strengths.

Question 1

Determine an upper bound solution for the load carrying capacity of the beam based on the yield line pattern shown on the figure with $\beta = 60^\circ$ and displacements corresponding to the translation mode with $\alpha = 0$. Compare the result with CPans and comment the difference.

Question 2

Determine an upper bound solution for the load carrying capacity of the beam based on the yield line pattern shown on the figure and displacements corresponding to the rotation mode specified by the rotation η about the upper side load point of the left beam part.

Problem 101

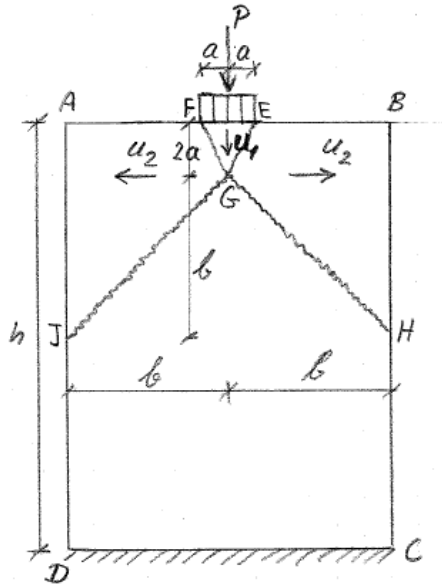

A vertical rectangular $h * 2b$ unreinforced concrete disk (= in-plane loaded plate) ABCD - see the figure - of thickness t is loaded by a rather concentrated vertical load (load resultant P) uniformly distributed over the rectangular area $2a * t$.

The concrete is modelled as a rigid-plastic material based on the modified Coulomb yield condition with $f_t = 0$.

Question 1

Determine an upper bound P_Y^+ for the yield load P_Y of P based on the indicated yield line pattern with vertical displacement u_1 of the wedge part of the disk and horizontal displacement $u_2 = \frac{1}{2}u_1$ of the other movable disk parts.

Problem 102

An orthogonal reinforced concrete disk is considered. The concrete is modelled as a rigid-plastic material based on the modified Coulomb yield condition with tension strength $f_t = 0$. A rebar is modelled as a uniaxial rigid-plastic material with yield stress f_Y in both tension and compression.

The MatLab function *YsReDisk* determines a point on the yield surface used in the disk, while the MatLab script *exeYsReDisk* applies *YsReDisk* to determine a section in the yield surface.

Question 1

Apply *YsReDisk* to determine the point $(\sigma_x, \sigma_y, \tau_{xy}) = (0, 0, \tau_{xy})$ on the yield surface used in a disk with $\Phi_x = \Phi_y = 0.2$ and test the result comparing with CP.

Question 2

Apply *exeYsReDisk* to determine the section $\sigma_y = 0$ of the yield surface. Consider the cases

- a) $\Phi_x = \Phi_y = 0.2$
- b) $\Phi_x = \Phi_y = 0.6$
- c) $\Phi_x = 0.6 \quad \Phi_y = 0.2$

and test the results as far as possible comparing with CP.

Problem 103

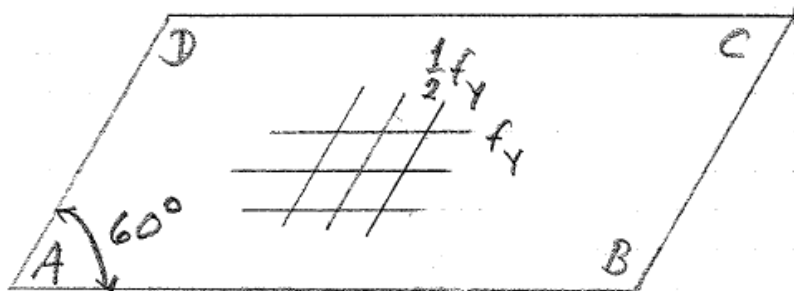

A parallelogram shaped reinforced concrete disk ABCD of thickness t , see the figure, is reinforced parallel with the edges. The reinforcement in each direction has the area A per unit length. The yield stress of the reinforcement in one direction is f_Y and in the other direction $\frac{1}{2}f_Y$.

Question 1

Determine the directions and the areas per unit length of the equivalent orthogonal reinforcement with yield stress f_Y .

Problem 104

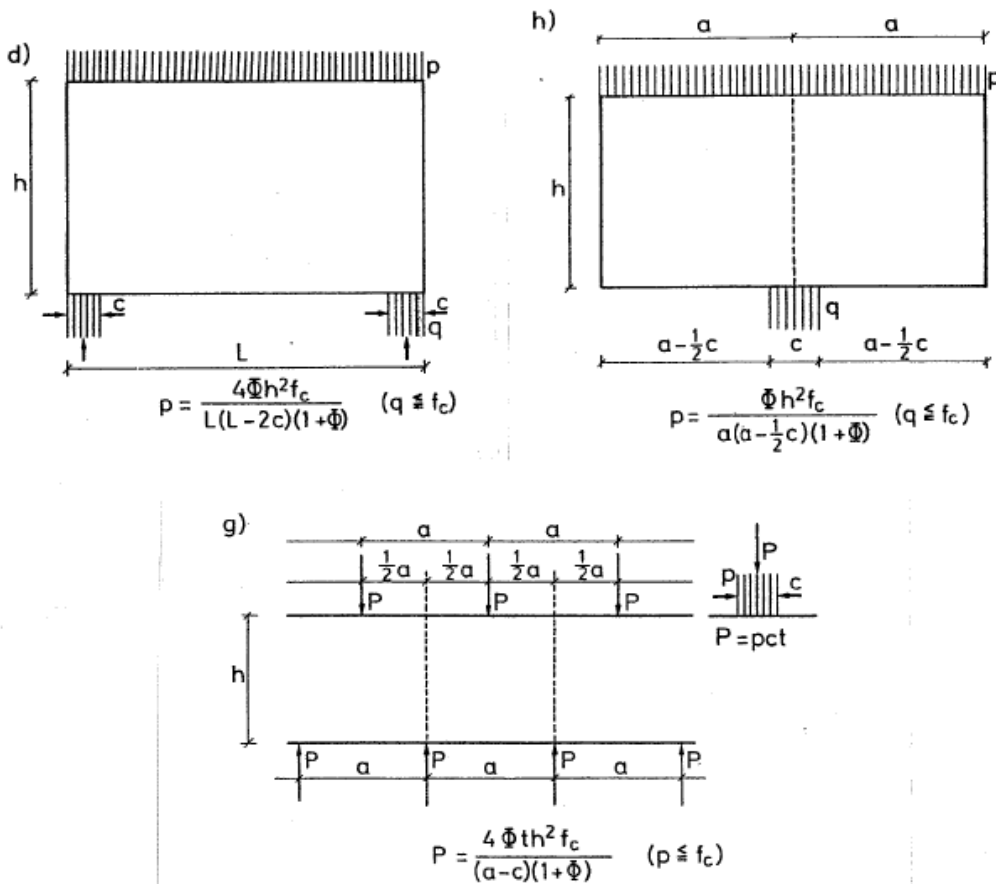

On the figure is shown the isotropic reinforced concrete disks d), g), h) of thickness t . As yield condition for the disk material is used CP (2.2.37). The load is a pressure load $p > 0$ per area unit in equilibrium with the reactions (the reaction pressure is indicated by q on d) and h)). Self-weight is neglected. For each disk is wanted:

Question 1

Determine an equilibrium stress field based on a constant stress triangle mesh.

Question 2

For $L = a = h$, $c = 0.2h$, $\Phi = 0.1$ determine a lower bound solution for the load carrying capacity and determine the deviation from the exact solution.

Question 3

Determine an upper bound solution for the load carrying capacity assuming a bending type mechanism in the symmetry sections and determine the deviation from the exact solution.

E06, LONpr1 (40% of 4 hours exam)

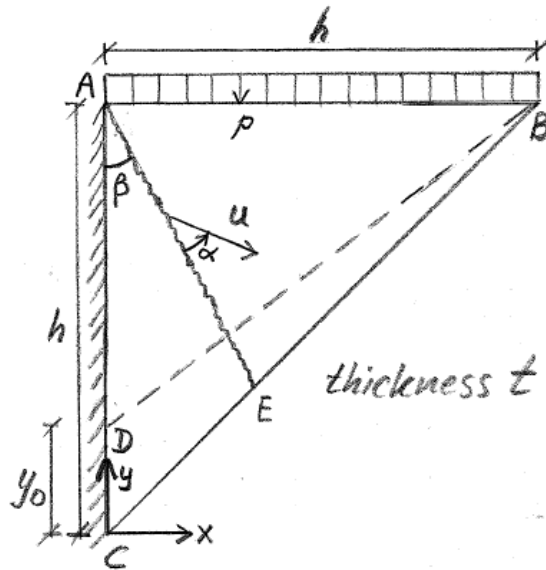

A concrete disk ABC, see the figure, of thickness t is reinforced homogeneous and orthotropic in the x, y coordinate directions.

The concrete and the reinforcement are modelled as rigid, perfectly plastic materials. The concrete is described as a modified Coulomb material with tension strength $f_t = 0$. The reinforcement strength in compression is neglected.

The concrete has the effective compressive design strength $f_{cd} = 25\text{MPa}$ and the reinforcement has the tensile design strength $f_{yd} = 400\text{MPa}$. The minimum reinforcement ratio is set to $r_{\min} = 0.002$.

The load is a pressure load $p > 0$ per area unit. Self-weight is neglected.

Question 1

Based on a constant stress triangle mesh with 2 triangles ABD and BCD, determine a set of equilibrium stresses in the disk.

Question 2

For $y_0 = 0.25h$ a set of equilibrium stresses in the disk is determined by $(\sigma_x, \sigma_y, \tau_{xy}) = p(\frac{4}{3}, -1, 0)$ in ABD and $(\sigma_x, \sigma_y, \tau_{xy}) = -4p(1, 1, 1)$ in BCD. For $p = 3\text{MPa}$, $h = 1800\text{mm}$, $t = 150\text{mm}$ determine the necessary tensile strengths f_{tx}, f_{ty} and investigate if the compression stress in the concrete is safe in each constant stress triangle.

Question 3

With a straight yield line AE, see the figure, and a displacement $u > 0$ with an angle $\alpha \geq 0$ with the yield line of disk part ABE (no displacement of disk part AEC) is wanted an upper bound solution for the load carrying capacity of the disk for $\beta = 45^\circ$, $\alpha = 0^\circ$, $f_{tx} = 4\text{MPa}$, $f_{ty} = 0$.

E06, LONpr2 (40% of 4 hours exam)

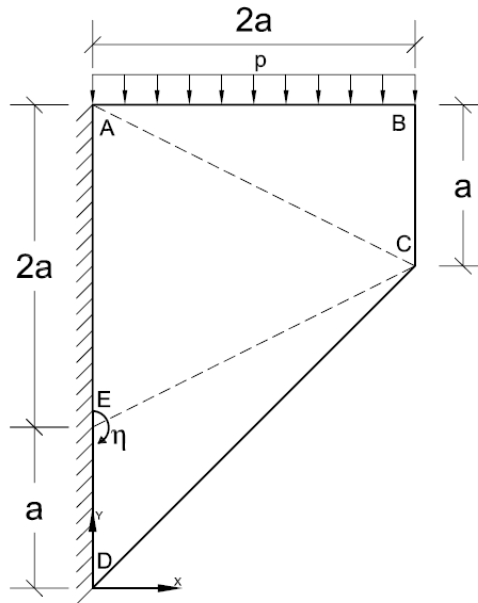

A concrete disk ABCD, see the figure, of thickness t is reinforced homogeneous and orthotropic in the x, y coordinate directions. Rebars in the x -direction cross the supporting section AD and are anchored in the support.

The concrete and the reinforcement are modelled as rigid, perfectly plastic materials. The concrete is described as a modified Coulomb material with tension strength $f_t = 0$. The reinforcement strength in compression is neglected.

The concrete has the effective compressive design strength $\nu f_{cd} = 15MPa$ and the reinforcement has the tensile design strength $f_{yd} = 300MPa$. The minimum reinforcement ratio is set to $r_{min} = 0.002$.

The load is a pressure load $p > 0$ per area unit. Self-weight is neglected.

Question 1

Based on a constant stress triangle mesh with 3 triangles ABC, ACE and CDE, determine a set of equilibrium stresses in the disk.

Question 2

A set of equilibrium stresses in the disk is determined by $(\sigma_x, \sigma_y, \tau_{xy}) = p(0, -1, 0)$ in ABC, $(\sigma_x, \sigma_y, \tau_{xy}) = \frac{1}{6} p(4, -5, -2)$ in ACE and $(\sigma_x, \sigma_y, \tau_{xy}) = -\frac{4}{3} p(1, 1, 1)$ in CDE. For $p = 5MPa$, $a = 900mm$, $t = 100mm$, determine the necessary tensile strengths f_{tx} , f_{ty} and investigate if the compression stress in the concrete is safe in each constant stress triangle.

Question 3

For $f_{tx} = 4MPa$ determine an upper bound solution for the load carrying capacity of the disk based on a rotation $\eta > 0$ of the disk about point E see the figure.

E06, LONpr3 (40% of 4 hours exam)

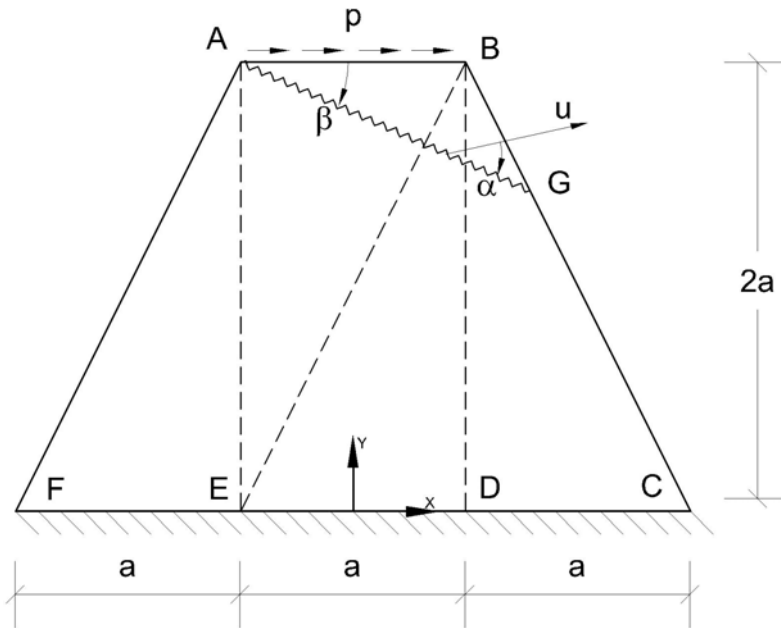

A concrete disk ABCDEF, see the figure, of thickness t is reinforced homogeneous and orthotropic in the x, y coordinate directions. Rebars in the y -direction cross the supporting section CDEF and are anchored in the support.

The concrete and the reinforcement are modelled as rigid, perfectly plastic materials. The concrete is described as a modified Coulomb material with tension strength $f_t = 0$. The reinforcement strength in compression is neglected.

The concrete has the effective compressive design strength $\nu f_{cd} = 20\text{MPa}$ and the reinforcement has the tensile design strength $f_{yd} = 400\text{MPa}$. The minimum reinforcement ratio is set to $r_{\min} = 0.002$.

The load consists of a constant shear stress $p > 0$ per area unit along AB. Self-weight is neglected.

Question 1

Based on a constant stress triangle mesh with 4 triangles AEF, ABE, BDE and BCD with zero stresses in triangle BCD, determine a set of equilibrium stresses in the disk.

Question 2

Symmetrization of the question 1 solution determines a more efficient set of equilibrium stresses in the disk. In AEF is obtained $(\sigma_x, \sigma_y, \tau_{xy}) = p(\frac{1}{4}, 1, \frac{1}{2})$ and in BCD $(\sigma_x, \sigma_y, \tau_{xy}) = p(-\frac{1}{4}, -1, \frac{1}{2})$. For each of these two triangles and for $p = 6\text{MPa}$, $a = 1000\text{mm}$, $t = 100\text{mm}$, determine the necessary tensile strengths f_{tx}, f_{ty} and investigate if the compression stress in the concrete is safe.

Question 3

With a straight yield line AG, see the figure, and a translation $u > 0$ with an angle $\alpha \geq 0$ with the yield line of disk part ABG is wanted an upper bound solution for the load carrying capacity of the disk for $\alpha = \beta = 30^\circ$ and $f_{tx} = f_{ty} = 6\text{MPa}$ in ABCDE. ■

11. ANSWERS TO SOME PROBLEMS

Prob 101. q1: $P_Y^+ = f_c t \left(\frac{5}{2} a + \frac{\sqrt{2}-1}{2} b \right)$

Prob 103. q1: $\theta = 15^\circ$, $A_\xi = A \frac{3+\sqrt{3}}{4} \cong A * 1.18$, $A_\eta = A \frac{3-\sqrt{3}}{4} \cong A * 0.32$

E06,LONpr1. q1: ABD: $(\sigma_x, \sigma_y, \tau_{xy}) = \left(\frac{p}{1-y_0/h}, -p, 0 \right)$, BCD: $(\sigma_x, \sigma_y, \tau_{xy}) = -\frac{ph}{y_0}(1,1,1)$; q2:

(before considering min reinforcement) ABD: $f_{tx} = 4MPa$, $f_{ty} = 0$, $\sigma_c = 3MPa$ (safe),

BCD: $f_{tx} = 0$, $f_{ty} = 0$, $\sigma_c = 24MPa$ (safe); q3: $p_Y^+ = 14.5MPa$

E06,LONpr2. q1: ABC: $(\sigma_x, \sigma_y, \tau_{xy}) = (0, -p, 0)$, ACE: $(\sigma_x, \sigma_y, \tau_{xy}) = \left(\frac{2}{3}p, -\frac{5}{6}p, -\frac{1}{3}p \right)$,

CDE: $(\sigma_x, \sigma_y, \tau_{xy}) = \left(-\frac{4}{3}p, -\frac{4}{3}p, -\frac{4}{3}p \right)$; q2: (before considering min reinforcement)

ABC: $f_{tx} = 0$, $f_{ty} = 0$, $\sigma_c = 5MPa$ (safe), ACE: $f_{tx} = 4Mpa$, $f_{ty} = 0$, $\sigma_c = 4.83MPa$ (safe),

CDE: $f_{tx} = 0$, $f_{ty} = 0$, $\sigma_c = 13.3MPa$ (safe); q3: $p_Y^+ = 7.75MPa$

E06,LONpr3. q1: AEF: $(\sigma_x, \sigma_y, \tau_{xy}) = \left(\frac{1}{2}p, 2p, p \right)$, ABE: $(\sigma_x, \sigma_y, \tau_{xy}) = \left(\frac{1}{2}p, 0, p \right)$,

BDE: $(\sigma_x, \sigma_y, \tau_{xy}) = (0, -2p, 0)$; q2: (before considering min reinforcement)

AEF: $f_{tx} = 4.5MPa$, $f_{ty} = 9MPa$, $\sigma_c = 6MPa$ (safe), BCD: $f_{tx} = 0$, $f_{ty} = 0$, $\sigma_c = 7.5MPa$ (safe); q3:

$p_Y^+ = 14.6MPa$

■

12. EQUIVALENT ORTHOTROPIC REINFORCEMENT IN A SOLID

In CP sec.2.2.3 is considered the determination of the orthotropic reinforcement in a disk, which - concerning the tension yield load - is equivalent to a given arbitrary reinforcement in the disk. Here is considered the same problem for a three dimensional solid. The notation from CP is used as far as possible.

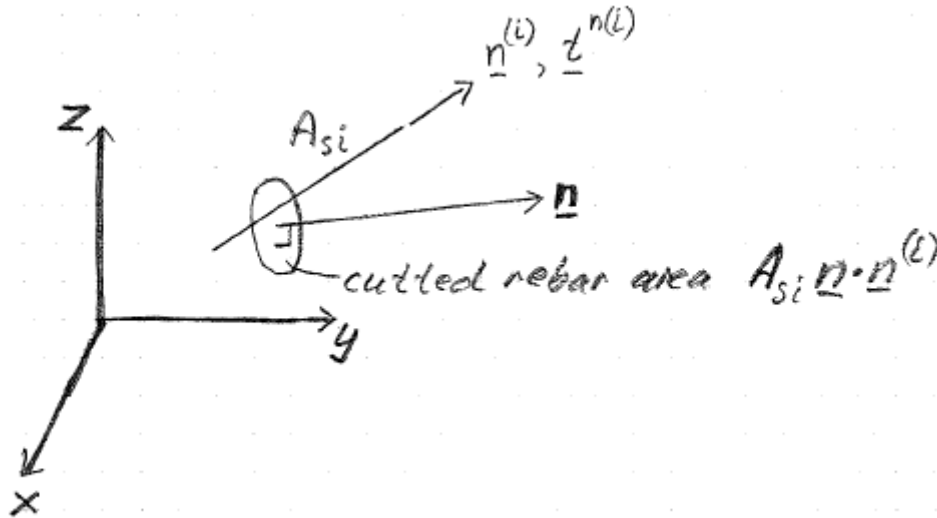

Figure 1: Reinforcement in direction i .

The solid is reinforced in m arbitrary directions. In direction i , $i = 1, 2, \dots, m$ with unit direction vector $\mathbf{n}^{(i)}$ see Fig.1, the reinforcement has the cross section area A_{si} per unit area of the solid and the tensile yield stress f_Y .

We consider now the case where all reinforcement yields in tension. First step is to determine the equivalent stress on a section with outward directed unit normal vector \mathbf{n} . From reinforcement i is obtained the stress vector contribution $\mathbf{t}^{n(i)} = f_Y A_{si} (\mathbf{n} \cdot \mathbf{n}^{(i)}) \mathbf{n}^{(i)}$, i.e. for the total reinforcement we get

$$\mathbf{t}^n = \sum_{i=1}^m \mathbf{t}^{n(i)} = \sum_{i=1}^m f_Y A_{si} (\mathbf{n} \cdot \mathbf{n}^{(i)}) \mathbf{n}^{(i)} \quad (1)$$

Next we want to determine those sections if any, where there are only normal stresses and no shear stresses on the section. The condition is obviously $\mathbf{t}^n = \lambda \mathbf{n}$, where λ is a yet unknown constant. Combining this with (1) gives

$$\sum_{i=1}^m f_Y A_{si} (\mathbf{n} \cdot \mathbf{n}^{(i)}) \mathbf{n}^{(i)} = \lambda \mathbf{n} \quad (2)$$

which as we shall see below is an eigenvalue problem for determination of \mathbf{n}, λ .

Using the component forms $\mathbf{n} = (n_x, n_y, n_z)$ and $\mathbf{n}^{(i)} = (n_x^{(i)}, n_y^{(i)}, n_z^{(i)})$ the summation in (2) is turned into

$$\begin{aligned} \sum_{i=1}^m f_Y A_{si} (\mathbf{n} \cdot \mathbf{n}^{(i)}) \mathbf{n}^{(i)} &= \sum_{i=1}^m f_Y A_{si} (n_x n_x^{(i)} + n_y n_y^{(i)} + n_z n_z^{(i)}) \mathbf{n}^{(i)} \\ &= n_x \sum_{i=1}^m f_Y A_{si} n_x^{(i)} \mathbf{n}^{(i)} + n_y \sum_{i=1}^m f_Y A_{si} n_y^{(i)} \mathbf{n}^{(i)} + n_z \sum_{i=1}^m f_Y A_{si} n_z^{(i)} \mathbf{n}^{(i)} \end{aligned}$$

and then (2) can be written as

$$\begin{bmatrix} \sum_{i=1}^m f_Y A_{si} n_x^{(i)} n_x^{(i)} & \sum_{i=1}^m f_Y A_{si} n_y^{(i)} n_x^{(i)} & \sum_{i=1}^m f_Y A_{si} n_z^{(i)} n_x^{(i)} \\ \sum_{i=1}^m f_Y A_{si} n_x^{(i)} n_y^{(i)} & \sum_{i=1}^m f_Y A_{si} n_y^{(i)} n_y^{(i)} & \sum_{i=1}^m f_Y A_{si} n_z^{(i)} n_y^{(i)} \\ \sum_{i=1}^m f_Y A_{si} n_x^{(i)} n_z^{(i)} & \sum_{i=1}^m f_Y A_{si} n_y^{(i)} n_z^{(i)} & \sum_{i=1}^m f_Y A_{si} n_z^{(i)} n_z^{(i)} \end{bmatrix} \begin{bmatrix} n_x \\ n_y \\ n_z \end{bmatrix} = \lambda \begin{bmatrix} n_x \\ n_y \\ n_z \end{bmatrix} \quad (3)$$

The 3×3 coefficient matrix in (3) is obviously a symmetric matrix. Then the eigenvalue problem (3) has 3 real solutions $\lambda_1, \lambda_2, \lambda_3$ with the orthogonal eigenvectors $\mathbf{n}_1, \mathbf{n}_2, \mathbf{n}_3$. Then in conclusion: the equivalent orthotropic reinforcement with yield stress f_Y must go in the directions $\mathbf{n}_1, \mathbf{n}_2, \mathbf{n}_3$ and have strengths defined by

$$f_Y A_{e1} = \lambda_1 \quad f_Y A_{e2} = \lambda_2 \quad f_Y A_{e3} = \lambda_3 \quad (4)$$

where A_{e1}, A_{e2}, A_{e3} are the cross sectional areas of the equivalent orthotropic reinforcement in direction 1,2,3.

Example

For non-orthogonal reinforcement as shown on Fig.2 with yield stress f_Y , determine the equivalent orthotropic reinforcement.

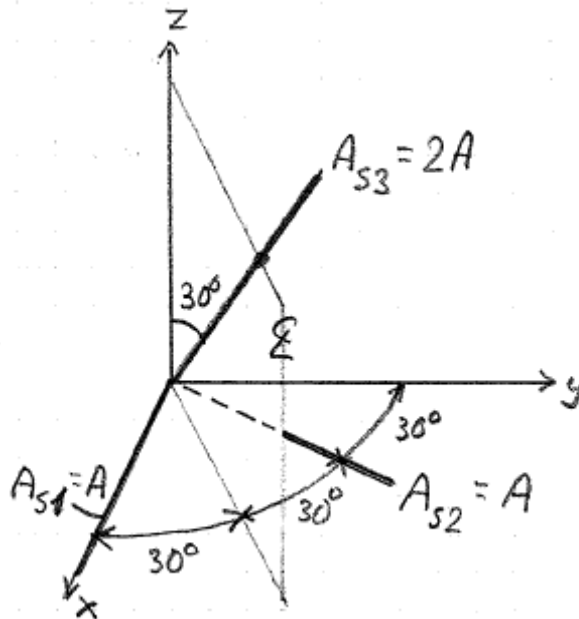

Figure 2: Non-orthogonal reinforcement.

Answer:

The unit direction vectors of the rebars are

$$\mathbf{n}^{(1)} = [1 \quad 0 \quad 0]$$

$$\mathbf{n}^{(2)} = \left[\frac{1}{2} \quad \frac{\sqrt{3}}{2} \quad 0 \right]$$

$$\mathbf{n}^{(3)} = \left[\frac{\sqrt{3}}{4} \quad \frac{1}{4} \quad \frac{\sqrt{3}}{2} \right]$$

Then (3) gives

$$f_Y A \begin{bmatrix} 1 + \frac{1}{4} + 2 \times \frac{3}{16} & 0 + \frac{\sqrt{3}}{4} + 2 \times \frac{\sqrt{3}}{16} & 2 \times \frac{3}{8} \\ 0 & 0 + \frac{3}{4} + 2 \times \frac{1}{16} & 2 \times \frac{\sqrt{3}}{8} \\ 0 & 0 & 2 \times \frac{3}{4} \end{bmatrix} \begin{bmatrix} n_x \\ n_y \\ n_z \end{bmatrix} = \lambda \begin{bmatrix} n_x \\ n_y \\ n_z \end{bmatrix}$$

sym

The solution of this eigenvalue problem is here obtained by the Matlab computation

```
S=[1+1/4+2*3/16  0+sqrt(3)/4+2*sqrt(3)/16  0+0+2*3/8
  0  0+3/4+2/16  0+0+2*sqrt(3)/8
  0  0  0+0+2*3/4];
```

```
% symmetrize
S(2,1)=S(1,2); S(3,1)=S(1,3); S(3,2)=S(2,3);
% solve
[V,D]=eig(S)
```

```
V =
 5.0000e-001  5.2057e-001  6.9210e-001
-8.6603e-001  3.0055e-001  3.9959e-001
-2.5640e-016 -7.9917e-001  6.0110e-001
D =
 5.0000e-001  0  0
 0  8.4861e-001  0
 0  0  2.6514e+000
```

Then the equivalent orthotropic reinforcement is determined by

$$f_Y A_{e1} = D(1,1) f_Y A \text{ in direction } \mathbf{n}^{(e1)} = V(:,1)$$

$$f_Y A_{e2} = D(2,2) f_Y A \text{ in direction } \mathbf{n}^{(e2)} = V(:,2)$$

$$f_Y A_{e3} = D(3,3) f_Y A \text{ in direction } \mathbf{n}^{(e3)} = V(:,3)$$

Test:

For test is utilized the symmetry of the reinforcement as indicated on Fig.2. Then one of the equivalent rebar directions must be normal to the symmetry plane i.e.

$(-\sin 30^\circ, \cos 30^\circ, 0) \approx (-0.500, 0.866, 0)$ corresponding to $V(:,1)$. The area of the equivalent reinforcement in this direction has only contributions from reinforcement 1 and 2 and because their angle with this direction is 60° , they contribute to the strength with $2f_Y A (\cos 60^\circ)^2 = \frac{1}{2} f_Y A$ corresponding to $D(1,1)$.

Another test is $A_{e1} + A_{e2} + A_{e3} = A_{s1} + A_{s2} + A_{s3}$. As both sides gives $4A$, this test is satisfied.

■

13. NUMERICAL DETERMINATION OF YIELD CONDITION FOR A REINFORCED SOLID MATERIAL

The determination of the yield condition is as in CP, sec.2.2.2 based on the lower bound theorem. The notation from CP is used as far as possible. The usual coordinate system x, y, z on Fig.1 has axes in the (equivalent) orthotropic reinforcement directions.

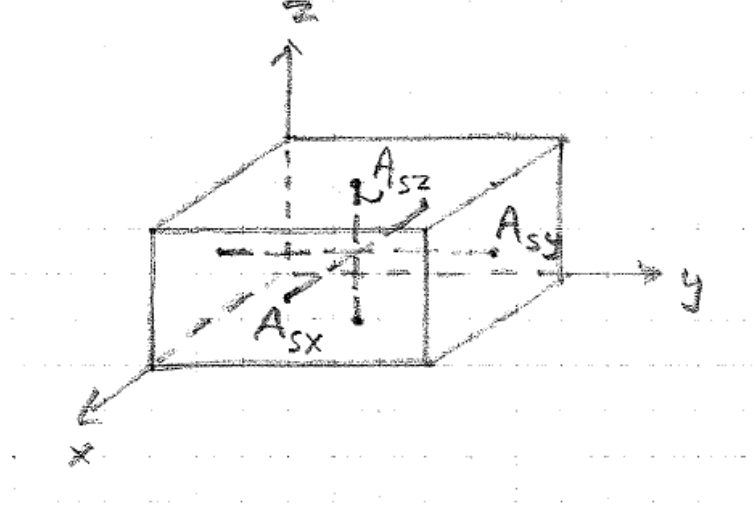

Figure 1: Reinforced solid.

The stresses on the boundary of the solid are written as $\lambda(\sigma_x^0, \sigma_y^0, \sigma_z^0, \tau_{yz}^0, \tau_{zx}^0, \tau_{xy}^0)$, where λ is the load factor. The stress in a rebar in the x-direction is called σ_{sx} , for a rebar in the y-direction is used σ_{sy} and for a rebar in the z-direction σ_{sz} .

The stress equilibrium on the boundary of the solid gives

$$\lambda \sigma_x^0 = \sigma_{sx} A_{sx} + \sigma_{cx} \quad \lambda \sigma_y^0 = \sigma_{sy} A_{sy} + \sigma_{cy} \quad \lambda \sigma_z^0 = \sigma_{sz} A_{sz} + \sigma_{cz} \quad (1)$$

$$\lambda \tau_{yz}^0 = \tau_{cyz} \quad \lambda \tau_{zx}^0 = \tau_{czx} \quad \lambda \tau_{xy}^0 = \tau_{cxy} \quad (2)$$

where A_{sx} is the cross section area of the rebars in the x-direction per unit area of the solid. A_{sy}, A_{sz} are defined analogously referring to the y, z -directions.

The yield conditions for both concrete and rebars must not be violated. For the rebars we have

$$-f_{Yx} \leq \sigma_{sx} \leq f_{Yx} \quad -f_{Yy} \leq \sigma_{sy} \leq f_{Yy} \quad -f_{Yz} \leq \sigma_{sz} \leq f_{Yz} \quad (3)$$

where f_{Yx}, f_{Yy}, f_{Yz} are the yield stresses of the rebar material in the x, y, z -directions.

Modified Coulomb formulation

For the concrete is here used the modified Coulomb yield condition from CP, i.e. when the principal concrete stresses are ordered $\sigma_{c1} \geq \sigma_{c2} \geq \sigma_{c3}$ we have

$$k\sigma_{c1} - \sigma_{c3} \leq f_c \quad \sigma_{c1} \leq f_A \quad (4)$$

The relation between the principal concrete stresses and the concrete stress components are obtained via the stress invariants defined by

$$I_1 = \sigma_{cx} + \sigma_{cy} + \sigma_{cz}$$

$$I_2 = \sigma_{cx}\sigma_{cy} + \sigma_{cy}\sigma_{cz} + \sigma_{cz}\sigma_{cx} - \tau_{cyz}^2 - \tau_{czx}^2 - \tau_{cxy}^2 \quad (5)$$

$$I_3 = \sigma_{cx} \sigma_{cy} \sigma_{cz} + 2\tau_{cyz} \tau_{cxz} \tau_{cxy} - \sigma_{cx} \tau_{cyz}^2 - \sigma_{cy} \tau_{cxz}^2 - \sigma_{cz} \tau_{cxy}^2$$

Applying (5) in the principal coordinate system for concrete stresses gives

$$I_1 = \sigma_{c1} + \sigma_{c2} + \sigma_{c3}$$

$$I_2 = \sigma_{c1} \sigma_{c2} + \sigma_{c2} \sigma_{c3} + \sigma_{c3} \sigma_{c1}$$

$$I_3 = \sigma_{c1} \sigma_{c2} \sigma_{c3}$$

Inserting these expressions in (5) gives the wanted relations

$$\sigma_{c1} + \sigma_{c2} + \sigma_{c3} = \sigma_{cx} + \sigma_{cy} + \sigma_{cz}$$

$$\sigma_{c1} \sigma_{c2} + \sigma_{c2} \sigma_{c3} + \sigma_{c3} \sigma_{c1} = \sigma_{cx} \sigma_{cy} + \sigma_{cy} \sigma_{cz} + \sigma_{cz} \sigma_{cx} - \tau_{cyz}^2 - \tau_{cxz}^2 - \tau_{cxy}^2 \quad (6)$$

$$\sigma_{c1} \sigma_{c2} \sigma_{c3} = \sigma_{cx} \sigma_{cy} \sigma_{cz} + 2\tau_{cyz} \tau_{cxz} \tau_{cxy} - \sigma_{cx} \tau_{cyz}^2 - \sigma_{cy} \tau_{cxz}^2 - \sigma_{cz} \tau_{cxy}^2$$

With (6) the principal concrete stresses $\sigma_{c1}, \sigma_{c2}, \sigma_{c3}$ are not ordered as (4) presupposes. Then (6) must be combined with the yield condition on the form

$$\begin{aligned} k\sigma_{c2} - \sigma_{c3} &\leq f_c & k\sigma_{c3} - \sigma_{c1} &\leq f_c & k\sigma_{c1} - \sigma_{c2} &\leq f_c \\ k\sigma_{c3} - \sigma_{c2} &\leq f_c & k\sigma_{c1} - \sigma_{c3} &\leq f_c & k\sigma_{c2} - \sigma_{c1} &\leq f_c \\ \sigma_{c1} &\leq f_A & \sigma_{c2} &\leq f_A & \sigma_{c3} &\leq f_A \end{aligned} \quad (7)$$

Of course (7) can be replaced by the more simple formulation

$$\sigma_{c1} \geq \sigma_{c2} \quad \sigma_{c2} \geq \sigma_{c3} \quad k\sigma_{c1} - \sigma_{c3} \leq f_c \quad \sigma_{c1} \leq f_A \quad (7a)$$

Given $(\sigma_x^0, \sigma_y^0, \sigma_z^0, \tau_{yz}^0, \tau_{zx}^0, \tau_{xy}^0)$, a solution $(\sigma_{sx}, \sigma_{sy}, \sigma_{sz}, \sigma_{cx}, \sigma_{cy}, \sigma_{cz}, \tau_{cyz}, \tau_{cxz}, \tau_{cxy}, \lambda)$ to (1-3,6-7) is obviously a lower bound solution. Maximizing the load parameter must give the yield load λ_Y

$$\max \lambda = \lambda_Y \quad (8)$$

The conditions (1-3,6-8) define a problem in non-linear convex optimization. It is non-linear because not all conditions are linear ((6^{2-3}) are non-linear). It is convex as a perfect plasticity problem. As a non-linear convex optimization problem it may be preferable from a computational point of view to use a smooth yield condition. This possibility is considered below.

Smoothed Mohr-Coulomb formulation

Here is considered the same problem as above, but the modified Coulomb yield condition is exchanged with a smoothed Mohr-Coulomb yield condition. This yield condition $f(I'_1, I'_2, I'_3)$, which can be closed, is expressed by a set of stress invariants

$$f = k_1 I'_3 + (-I'_1)^\gamma I'_2 + (1 - \frac{f_A}{f_s})^3 (k_1 - 9) \leq 0 \quad (9)$$

The stress invariants I'_1, I'_2, I'_3 are defined from the shifted non-dimensional stresses

$$\sigma'_x = \frac{\sigma_{cx}}{f_s} - 1, \quad \sigma'_y = \frac{\sigma_{cy}}{f_s} - 1, \quad \sigma'_z = \frac{\sigma_{cz}}{f_s} - 1, \quad \tau'_{yz} = \frac{\tau_{cyz}}{f_s}, \quad \tau'_{zx} = \frac{\tau_{cxz}}{f_s}, \quad \tau'_{xy} = \frac{\tau_{cxy}}{f_s}, \quad (10)$$

i.e.

$$\begin{aligned} I'_1 &= \sigma'_x + \sigma'_y + \sigma'_z \\ I'_2 &= \sigma'_x \sigma'_y + \sigma'_y \sigma'_z + \sigma'_z \sigma'_x - \tau'^2_{yz} - \tau'^2_{zx} - \tau'^2_{xy} \\ I'_3 &= \sigma'_x \sigma'_y \sigma'_z + 2\tau'_{yz} \tau'_{zx} \tau'_{xy} - \sigma'_x \tau'^2_{yz} - \sigma'_y \tau'^2_{zx} - \sigma'_z \tau'^2_{xy} \end{aligned} \quad (11)$$

The yield condition (9) contains four material constants: $k_1 > 9$ is the friction parameter, $\gamma \leq 1$ the closing parameter (not closed for $\gamma = 1$), $f_s > 0$ the shift stress and f_A the separation resistance. A further discussion of this yield condition is found in the notes LON: Computational plasticity.

Inserting (10) in (11) and the obtained result in (9) express the yield condition by the stress components, i.e.

$$f(\sigma_{cx}, \sigma_{cy}, \sigma_{cz}, \tau_{cyz}, \tau_{czx}, \tau_{cxy}) \leq 0 \quad (12)$$

thus avoiding invariant expressions in the optimization formulation.

Given $(\sigma_x^0, \sigma_y^0, \sigma_z^0, \tau_{yz}^0, \tau_{zx}^0, \tau_{xy}^0)$, a solution $(\sigma_{sx}, \sigma_{sy}, \sigma_{sz}, \sigma_{cx}, \sigma_{cy}, \sigma_{cz}, \tau_{cyz}, \tau_{czx}, \tau_{cxy}, \lambda)$ to (1-3,12) is obviously a lower bound solution. Maximizing the load parameter must give the yield load λ_Y . The conditions (1-3,8,12) defines a problem in non-linear convex optimization.

Numerical solution

On Figure 2 is shown a section in the $\sigma_x \tau_{xy}$ -plane of the yield condition for the reinforced solid. Both the modified Coulomb (mC) and the smoothed Mohr-Coulomb (sMC) has been used for the solid. The reinforcement is isotropic with reinforcement degrees $\Phi_x = \Phi_y = \Phi_z = 0.1$ ($\Phi_x = \frac{A_{sx} f_Y}{f_c}$ etc.). The mC-parameters are $k=4, f_A = 0.1 f_c$. For sMC with $\gamma=1$ is used the 'equivalent' parameters $k_1 = 13.5, f_s = \frac{1}{3} f_c, f_A = 0.1 f_c$.

With the applied solution function MATLAB's *fmincon*, it is difficult to obtain a solution for mC and the curve irregularities indicate convergence problems. Contrarily it is easy to get a solution with the smooth sMC using a zero solution vector as starting point.

Compared with a disk solution minor three-dimensional effects are seen corresponding to utilization of the reinforcement in the y,z -directions in tension improving the compression state of the solid.

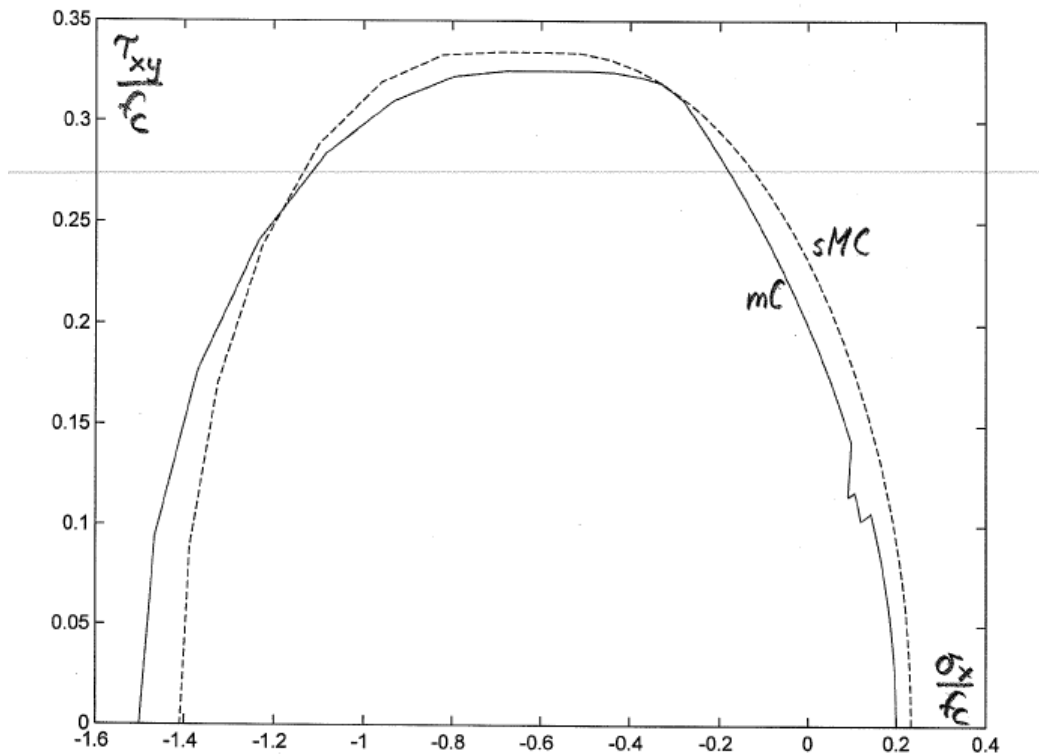

Figure 2: Section in yield surfaces for reinforced solid.

Modified Coulomb – positive semidefinite formulation

The Coulomb yield condition (4¹) can be written on positive semidefinite form Krabbenhøft et al, Int. J. Solids Struct. 44 (2007) 1533-1549. This is interesting from a computational point of view, because efficient numerical solution methods exist for positive semidefinite optimization Sturm, Optimization Methods and Software 11-12 (1999) 625-653 with SeDuMi and Löfberg, Proceedings of the CACSD Conference, 2004 with YALMIP.

Below is made a positive semidefinite formulation of the modified Coulomb yield condition (4¹⁻²). This is included in the formulation of the yield condition for a reinforced concrete solid. Finally a section in the yield surface is determined numerically by positive semidefinite optimization using the lower bound theorem. We are working in the real number domain.

A positive semidefinite symmetric matrix \mathbf{A} satisfies

$$\mathbf{x}^T \mathbf{A} \mathbf{x} \geq 0 \text{ for arbitrary vectors } \mathbf{x} \quad (13)$$

This is written as

$$\mathbf{A} \succeq \mathbf{0} \quad (14)$$

With this notation the Coulomb condition is written as

$$\begin{aligned} \boldsymbol{\sigma}_c + k\alpha \mathbf{I} &\succeq \mathbf{0} \\ -\boldsymbol{\sigma}_c + \left(\frac{f_c}{k} - \alpha\right) \mathbf{I} &\succeq \mathbf{0} \end{aligned} \quad (15)$$

where $\boldsymbol{\sigma}_c$ is the stress tensor for the concrete

$$\boldsymbol{\sigma}_c = \begin{bmatrix} \sigma_{cx} & \tau_{cxy} & \tau_{cxz} \\ \tau_{cyx} & \sigma_{cy} & \tau_{cyz} \\ \tau_{czx} & \tau_{czy} & \sigma_{cz} \end{bmatrix} \quad (16)$$

with principal stresses $\sigma_{c1} \geq \sigma_{c2} \geq \sigma_{c3}$, α an auxiliary variable and \mathbf{I} a unit matrix

$$\mathbf{I} = \begin{bmatrix} 1 & 0 & 0 \\ 0 & 1 & 0 \\ 0 & 0 & 1 \end{bmatrix} \quad (17)$$

In order to prove (15) this is obviously equivalent to

$$\sigma_{c3} + k\alpha \geq 0$$

$$-\sigma_{c1} + \left(\frac{f_c}{k} - \alpha\right) \geq 0$$

Next α is isolated (Dines method) giving

$$-\frac{\sigma_{c3}}{k} \leq \alpha \leq -\sigma_{c1} + \frac{f_c}{k}$$

i.e.

$$-\frac{\sigma_{c3}}{k} \leq -\sigma_{c1} + \frac{f_c}{k}$$

or

$$k\sigma_{c1} - \sigma_{c3} \leq f_c$$

which is the Coulomb condition (4¹).

With (4²) written as $-\boldsymbol{\sigma}_c + f_A \mathbf{I} \succeq \mathbf{0}$, the modified Coulomb yield condition (4¹⁻²) on positive semidefinite form is

$$\begin{aligned}
-\sigma_c + f_A \mathbf{I} &\succeq \mathbf{0} \\
\sigma_c + k\alpha \mathbf{I} &\succeq \mathbf{0} \\
-\sigma_c + \left(\frac{f_c}{k} - \alpha\right) \mathbf{I} &\succeq \mathbf{0}
\end{aligned} \tag{18}$$

Given $(\sigma_x^0, \sigma_y^0, \sigma_z^0, \tau_{yz}^0, \tau_{zx}^0, \tau_{xy}^0)$, a solution $(\sigma_{sx}, \sigma_{sy}, \sigma_{sz}, \sigma_{cx}, \sigma_{cy}, \sigma_{cz}, \tau_{cyz}, \tau_{czx}, \tau_{cxy}, \lambda, \alpha)$ to (1-3,18) is obviously a lower bound solution. Maximizing the load parameter must give the yield load λ_Y

$$\max \lambda = \lambda_Y \tag{19}$$

The conditions (1-3,18-19) define a problem in positive semidefinite optimization. The numerically determined solution on Figure 3 shows a section in the $\sigma_x \tau_{xy}$ -plane of the yield condition for the reinforced solid for the same data as used for Figure 2 and now without the computational problems mentioned in connection with Figure 2 for mC.

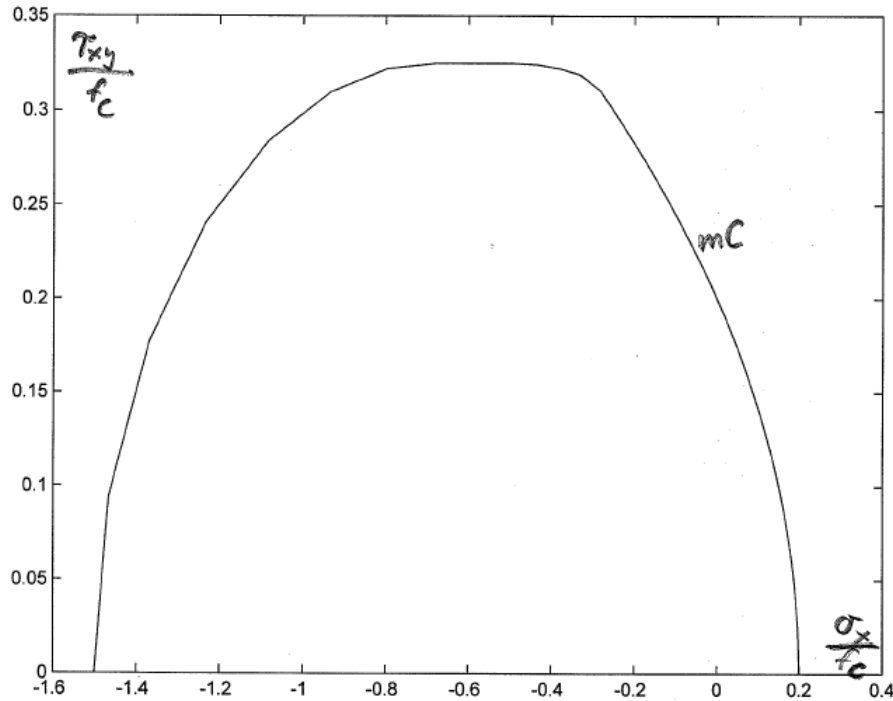

Figure 3: Section in yield surface for reinforced solid obtained by positive semidefinite optimization.

The conditions (18) can be simplified somewhat as proposed by Löfberg. First (18^{1,3}) with α named α_1 are written

$$\sigma_c \preceq f_A \mathbf{I} \quad \text{and} \quad \sigma_c \preceq \left(\frac{f_c}{k} - \alpha_1\right) \mathbf{I}$$

and then collected to

$$\sigma_c \preceq \min \left\{ f_A, \frac{f_c}{k} - \alpha_1 \right\} \mathbf{I} \equiv \alpha_2 \mathbf{I} \tag{20}$$

where last equal sign defines the scalar variable α_2 . Now (20) is rewritten

$$\begin{aligned}
\boldsymbol{\sigma}_c &\leq \alpha_2 \mathbf{I} \\
\alpha_2 &\leq f_A \\
\alpha_2 &\leq \frac{f_c}{k} - \alpha_1
\end{aligned}
\tag{21}$$

Using (21) the alternative formulation of (18) is obviously

$$\begin{aligned}
-\boldsymbol{\sigma}_c + \alpha_2 \mathbf{I} &\geq \mathbf{0} \\
\boldsymbol{\sigma}_c + k\alpha_1 \mathbf{I} &\geq \mathbf{0} \\
\alpha_2 &\leq f_A \\
\alpha_2 &\leq \frac{f_c}{k} - \alpha_1
\end{aligned}
\tag{22}$$

i.e. compared with (18) the number of semidefinite conditions has been reduced by 1, while 2 extra scalar inequalities have been included. Of course replacing (18) with (22) still gives the yield surface section shown on fig. 3.

■