



## Robust Design for IoT – On the Relevance of Mechanical Design for Robust Sensor Integration in Connected Devices

**Juul-Nyholm, H. B.; Eifler, T.; Ebro, M.**

*Published in:*  
Proceedings of the Design Society: DESIGN Conference

*Link to article, DOI:*  
[10.1017/dsd.2020.326](https://doi.org/10.1017/dsd.2020.326)

*Publication date:*  
2020

*Document Version*  
Publisher's PDF, also known as Version of record

[Link back to DTU Orbit](#)

*Citation (APA):*  
Juul-Nyholm, H. B., Eifler, T., & Ebro, M. (2020). Robust Design for IoT – On the Relevance of Mechanical Design for Robust Sensor Integration in Connected Devices. In *Proceedings of the Design Society: DESIGN Conference* (Vol. 1, pp. 235-244). Cambridge University Press. <https://doi.org/10.1017/dsd.2020.326>

---

### General rights

Copyright and moral rights for the publications made accessible in the public portal are retained by the authors and/or other copyright owners and it is a condition of accessing publications that users recognise and abide by the legal requirements associated with these rights.

- Users may download and print one copy of any publication from the public portal for the purpose of private study or research.
- You may not further distribute the material or use it for any profit-making activity or commercial gain
- You may freely distribute the URL identifying the publication in the public portal

If you believe that this document breaches copyright please contact us providing details, and we will remove access to the work immediately and investigate your claim.



# ROBUST DESIGN FOR IOT - ON THE RELEVANCE OF MECHANICAL DESIGN FOR ROBUST SENSOR INTEGRATION IN CONNECTED DEVICES

H. B. Juul-Nyholm <sup>1,✉</sup>, T. Eifler <sup>1</sup> and M. Ebro <sup>2</sup>

<sup>1</sup> DTU-Technical University of Denmark, Denmark, <sup>2</sup> Novo Nordisk A/S, Denmark

✉ hbaju@mek.dtu.dk

## Abstractw

The terms IoT and Industry 4.0 are promising increasingly sophisticated solutions, but the realisation will depend on the inclusion of robust and reliable sensors. If the gathered data is flawed or inaccurate the performance of the whole system will be compromised. By reviewing research on robustness indicators, mechatronics and sensor properties as well as listing mechanical noise factors and providing an electromechanical trade-off example, the paper highlights the importance of considering both mechanical and electrical noise factors and robustness in early development of connected devices.

*Keywords: robust design, design trade-offs, mechatronics, position sensors, internet of things (IoT)*

## 1. Introduction

Connected products and systems, usually referred to as IoT-devices or as a part of Industry 4.0 concepts, promise immense value for businesses across a wide range of industry sectors. However, one frequently neglected aspect is that the ability to really unlock this potential will depend on a robust and reliable performance of the integrated sensor systems. These systems allow for accurate sensing and registering of physical quantities, which can be used to improve the performance of the device either through direct feedback or through data management and requires a careful integration into the overall mechanical system. If the performance of a sensor system is sensitive to variation, the quality and safety of the feedback or data systems relying on it might be compromised.

A sensor's ability to accurately measure a physical quantity is generally described with quantitative properties like span, accuracy, resolution, linearity, repeatability etc. (Nyce, 2016). While these properties can be useful when comparing different sensors to integrate or retrofit, they do not specify the origin of e.g. the non-linearity of the integrated sensor. On top of this, many of the properties are interdependent and some of them may arise from mechanical aspects frequently neglected in the design process because of the focus on electronic filtering and control as well as data processing. This focus on electronics is also manifested through a sequential concept generation which too often limits mechanical considerations to the use of parametric optimization or detailed multi-physical simulations of the matured system at a late design stage (Torry-Smith et al., 2013b).

Based on the example of position sensors, this paper therefore aims at highlighting the relevance of research on mechanical design methods enabling robust sensor integration. It is shown (1) which mechanical noise factors have a relevant impact on the performance of the electronics and software and (2) how the dependencies between mechanical, electrical and software domains create trade-offs.

While these trade-offs could be addressed by considering mechanics in the early development process, the presented literature review shows that early mechatronic robustness assessments are not part of the currently available approaches. Lastly, the paper therefore (3) illustrates and discusses the sparse number of found statements on variation and trade-off mitigation strategies for encoders.

In general, position sensors convert mechanical motion through electronics to logical code representing position or displacement. Because the mechanics of interest is translated through a multitude of energy forms, the logical code will be subject to a range of noise contributions from variation in the production, operation and environment that might compromise the sensor performance. Based on a case study of a conductive angular encoder, it is shown how the mechanical structure's sensitivity towards variation in this case feeds into the other domains and should therefore be considered as an integrated part of the design of robust sensors. This includes design trade-offs, whose presence are indicators of robustness issues (Göhler and Howard, 2015), and which might appear between the different domains.

The remainder of the paper is structured as follows. In Section 2, a literature review is presented for three designated areas related to the robustness of integrated sensors; trade-offs and robust design, robust design of mechatronics, and sensor properties and mechanical noise factors. In Section 3, angular encoders are introduced, before their generic noise factors are identified and categorised and a specific trade-off example of the reader arm contact force is presented. Section 4 then presents a structured overview of currently available mitigation. A summary and a discussion are provided in Section 5.

## 2. Literature review

### 2.1. Trade-offs as early indicators of robust design

Robust Design aims at designing products that show a consistently high quality and performance despite noise factors such as production or assembly tolerances, deformation under intended and unintended load scenarios or ambient conditions of use (Taguchi et al., 2005). However, traditional Robust Design approaches largely focus on parameter design studies with matured solutions, which usually require costly and time-intensive experiments or simulations. Therefore, several authors point to the need and potential of early stage robust design strategies (e.g. Jugulum and Frey, 2007; Eifler and Howard, 2018), seeking to ensure robustness of mechanical products as early as possible. This idea of a Robust Design Methodology (RDM) prescribing systematic efforts to achieve insensitivity to noise factors, applied in all development phases (Arvidsson and Gremyr, 2007) does not yet expand to other domains though.

Robust Design of mechatronic systems consequently reverts to simulation and experimentation in most cases (see below). At the same time, previous research on RDM also illustrates that the existence of trade-offs in a design, i.e. the existence of conflicting design objectives, is an important driver for robustness in mechanical systems (Göhler et al., 2016). Given the largely interdependent functionality in mechatronic systems, this work promises a suitable basis for further investigation.

### 2.2. Robust design of mechatronics

Engineering design theory generally deals with the conceptualization of basic solution principles as well as the embodiment of structures, forms, and materials to achieve the intended product functions. While the goal is to diverge and explore design alternatives in order not to overlook superior designs, the development of mechatronic products is unfortunately too often divided into the mechanical, electrical and software engineering disciplines, even though the function of the product relies on the interaction between them (Torry-Smith et al., 2013b). Among other aspects, this means that the effect of the chosen mechanical solution on the electrical performance will not be evaluated before later in the process where robustness, performance and cost is already predisposed, and changes are expensive to make.

Literature on design guidelines for electromechanics revolves around the challenge of managing and exploiting the overlap between the involved domains during the design process. Pahl and Beitz for example, highlight the importance of setting the right team and transferring complexity to the system software, while Torry-Smith et al. (2013b) conclude that sound interdisciplinary synthesis would require a common language. Based on case studies, Torry-Smith et al. (2013a) present a list of interdisciplinary

management approaches divided into dependency categories to use as a checklist for analysing electromechanical concepts.

Another way of managing the complex task of synthesizing a multidisciplinary, mechatronic system is through the application of computer-based frameworks. According to [Sarkar et al. \(2017\)](#) computer-aided conceptual design adopts either an analogy-based or a synthesis-based approach. Analogy-based frameworks gather existing designs and associated properties to be combined in new ways to realize new design structures, e.g. [Dumitrescu et al. \(2012\)](#). Synthesis-based frameworks use either functions or grammar to develop alternative solutions for evaluation and selection, e.g. [Königseder and Shea \(2014\)](#). While previous research includes assessment of the generated mechatronic concepts, robustness is usually not considered. An exception is [Chakrabati et al. \(2011\)](#), who generate electrical sensor structures based on generic components from a physical laws and effects database and desired in- and outputs. Building on this, [Sarkar et al. \(2015 and 2017\)](#) show how the database can be used to synthesize sensor concepts and assess their comparative robustness by associating functional building blocks with noise factors.

In contrast to the synthesis approaches, a large part of the literature focusses almost exclusively on the assessment of largely matured mechatronic solutions, also in terms of their robustness. Examples are [Egel \(2009\)](#) suggesting Monte Carlo simulations for mechatronic network optimization and [Bilel et al. \(2017\)](#) and [Lei et al. \(2017\)](#) describing a range of different optimization methods for electromechanical machines and highlighting the importance of robustness objectives in the algorithm. Additionally, and in line with traditional robust design analyses, [Akbarzadeh et al. \(2012\)](#) models variables and noise contributions analytically to identify sensitive design parameters. This would also be possible with more detail using designated multi-physics tools provided by ANSYS or COMSOL as presented by [Anadkat and Rangachar \(2015\)](#) for sensing electromechanics and [Forsslund and Galvez \(2011\)](#) for robustness assessments. However, corresponding analyses require digitization of geometries and are currently computationally expensive as shown by [Nerenst et al. \(2019\)](#).

In conclusion, only few of the authors actually treat or comment on an integrated view on the different domains in development. However, [Alyaqout \(2010\)](#), [Janschek \(2011\)](#) and [Villarreal-Carvantes \(2012\)](#) present an initial demonstration of concurrent design of structure and control with promising results, in one instance supported by experiments ([Villarreal-Carvantes, 2012](#)).

### 2.3. Mechanical noise factors for sensors

Sensor accuracy is traditionally reported by stating properties such as span and bandwidth ([Nyce, 2016](#)) as well as characteristics of the transfer function between the physical input and the electrical output. However, when designing sensor systems, the underlying noise factors or sources of error, are important to consider and mitigate in order to obtain robust measurements. This implies a thorough understanding of the origin of the noise factors, which could be supported by categorisation according to [Carr's \(1993\)](#) five error source categories for sensors.

The first category includes the characterisation noise factors impacting the transfer function. These static noise factors are fundamental for the description of essential properties such as the accuracy, linearity and hysteresis ([Nyce, 2016](#)). Furthermore, static characteristics also include the scale resolution and repeatability, which are defining the smallest incremental change that can be sensed and the deviation of consecutive measurements under similar conditions ([Nyce, 2016](#)).

The second category, insertion noise factors, can be due to additional mass or friction that an integrated sensor adds to a device but might also be due to an unfortunate combination of physical input and sensor design. An example of a measurable property useful for sensor integration is the cross-axis sensitivity ([Nyce, 2016](#)). It describes the sensitivity towards inputs from other physical phenomena than the one of interest, e.g. the sensitivity towards a radial force for a sensor designed for measuring rotation.

The dynamic properties, the third category, of a sensor system include phase shift, sampling rate, resonances and damping ([Nyce, 2016](#)). These properties are inherently electromechanical, and their significance depends heavily on the application i.e. the needed responsiveness, the rapidness of the physical changes and required accuracy.

As the fourth category, the environmental effects like temperature, pressure and shock should be considered when designing a sensor for a specific application. The sensitivity towards temperature

depends on the thermal expansion of positioning parts and the conductivity of current conducting elements. It is often one of the greatest contributors to the error budget in the electronics (Nyce, 2016). These four categories will be used in this paper to group and contextualise (Figure 1) mechanical noise factors impacting sensor performance. The fifth category representing application errors is not included as operator errors can be neglected for the presented case example. When reviewing the literature for mechanical noise factors for angular encoders, few references focus on the noise factors and explicitly apart from Nyce (2016) and Ellin and Dolsak (2008). However, some papers seek to improve encoder performance by design (Mancini et al., 1998; Lequesne and Schroeder, 1999; Carr et al., 2008; Ernst, 1988; Kuzdrall, 1992; Stephens, 2007; Pitney, 1973) or through calibration (Smith, 1991; Qin et al., 2009). The encoder types and applications of the listed references vary, but the fundamental error sources are the same.

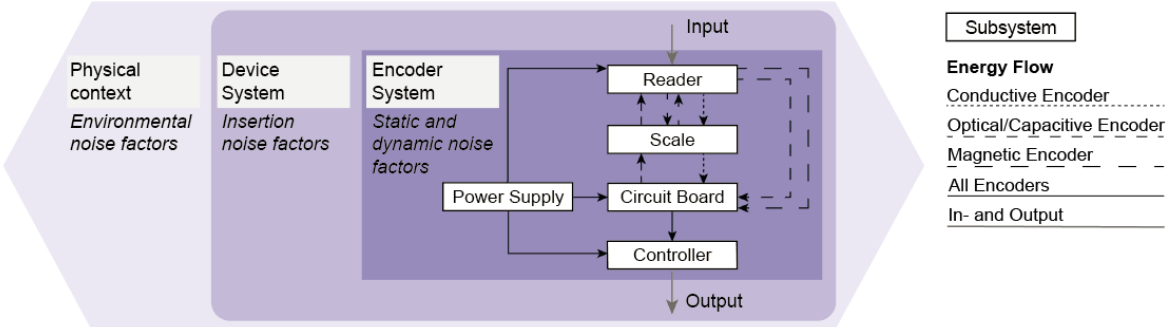

Figure 1. Encoder subsystems and energy flows nesting inside mechanical device and physical context with corresponding noise factor categories

### 3. Robustness case example: Angular contact encoder

#### 3.1. Introducing the angular contact encoder

An angular encoder is a mechatronic device converting angular position into logical codes by means of electronics. It can be used to measure position, displacement and velocity, and it consists of five subsystems as indicated by the boxes in Figure 1. The reader is rotated relative to the scale by an input directly representing the angular motion that the encoder is measuring. The reading of position is made possible because the scale consists of a known, binary pattern. The binary output from the reader and the scale is classified by the circuit board and interpreted by the logical controller. The encoder is powered by the power supply.

Angular encoders can be either absolute or incremental depending on the application. They mainly have four different working principles: The reader and scale pair can be conductive, optical, magnetic or capacitive. These working principles have different energy flows between the reader, scale and circuit board as represented by the punctuated lines in Figure 1. In conductive encoders, also referred to as contact encoders, a brush or a wiper slides over a conductive scale pattern in an insulated base. The contact between the reader brushes and the conductive pads closes different logical bit circuits in the circuit board and thereby creates a signal of the reader position (Nyce, 2016). Optical, capacitive and magnetic encoders exploit contactless reader and scale interactions and are therefore able to sense angular motion for different applications, at different resolutions and at a different cost. Conductive encoders were the first type to be developed, but due to friction and wear, optical and magnetic encoders have taken over most applications today. In this paper, conductive contact encoders are used as a case example due to their simplicity and continued application in cost critical devices.

The noise factors influencing the measurement of angular position can be categorised according to Carr’s (1993) error source categories, as presented above and as shown in Figure 1. Static and dynamic characteristics are associated with the design of the encoder, while the inputs as well as the insertion noise factors are properties of the device that the encoder is measuring on. The noise factors associated with the environment in which the device is operating are influencing both the device and the encoder as they are nested inside the relevant physical context.

In Figure 2, a P-diagram illustrating the conversion from input to output through an angular contact encoder is shown. The noise factors include all system levels depicted in Figure 1, but in the design of the encoder system only design parameters of the chosen embodiment are at disposition for ensuring the performance of the conversion to an electrical signal.

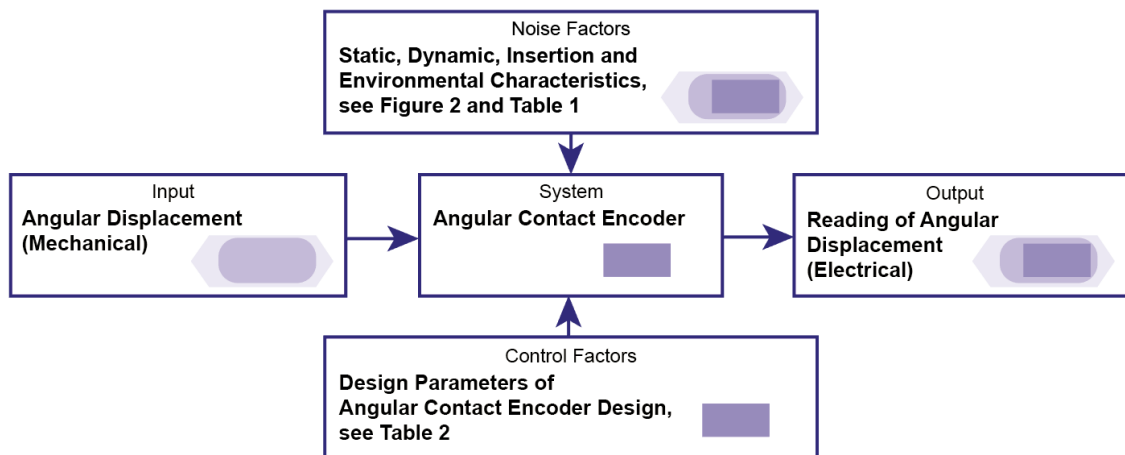

Figure 2. P-diagram for the angular contact encoder with symbols referring to the system levels of Figure 1

### 3.2. Mechanical noise factors

Considering the above, a thorough understanding of the noise factors and their influence on the mechanical, electrical and software domains is crucial for the design process. As a first step, Table 1 categorises noise factors for angular encoders identified in corresponding references according to the categories suggested by Carr (1993). Based on the literature review, this overview is extended by indicating which engineering domains the noise factors affect directly and whether the noise factors lead to consistent or random errors of the sensing performance of the overall device. This highlights the importance of mechanical design for robust encoder systems and provides an overview of which domains should be included when considering mechanical noise factors. The noise categories are not exclusive. For example, friction is not only a noise factor associated with insertion but is also dependent on and caused by dynamics. The direct influence on domains reflects the effect on the specific type of variation. To illustrate the content, some examples of noise factors categorised as characteristics and insertion factors are given in the following.

The static characteristics of an encoder rely on the relative position of the reader points to the scale as well as an interpretable electrical signal. The reader point positions in a contact encoder depends on the mechanical suspension and the characteristics of the reader arm. The signal from both optical and magnetic readers equally depend on both the emitted light or radiation intensity and the direction of it (Ellin and Dolsak, 2008; Carr et al., 2008). This can be compared to the extension of the contact area in contact encoders, where the pretension of the reader point arms ensures contact between the rotating reader and the scale pads (Pitney, 1973), as all three technological variations influence the detection of scale pad edges. The size of the error depends on the detection threshold (Lequesne and Schroeder, 1999). The functional influence of the mechanical design of the contact reader arm is used as the electromechanical trade-off example in Section 3.4.

Other mechanical influences on the reader-scale interface are the scale resolution and an incorrect scale shape resulting in wrongly positioned scale pad edges, noncircularity or noncoplanarity (Smith, 1991).

When the reader and scale are combined in the assembly more errors are potentially introduced. Eccentricity or displacement error is typically one of the largest sources of position error (Mancini et al., 1998; Stephens, 2007), but is consistent along the span (Qin et al., 2009). Furthermore, the scale and reader can also be subject to swash, where they are mutually tilted (Ellin and Dolsak, 2008; Stephens, 2007). According to Qin et al. (2009) swash and eccentricity in optical angular encoders have the same consistent effect. However, this does not apply to contact encoders as the reader contact

relies on a compliant suspension arm. Thus, the reader error in conductive encoders is sensitive to swash as a function of the sensitivity of the contact arm. Swash and eccentricity are illustrated in Figure 3. Low harmonic effects like eccentricity and swash have a significant impact compared to higher harmonics, because of larger sinusoidal amplitude.

**Table 1. Summary of noise factors, domain (Mechanical/Electrical/Software) influences and noise consistency (Yes/No); References: (1) Nyce (2016), (2) Ellin and Dolsak (2008), (3) Mancini et al. (1998), (4) Smith (1991), (5) Qin et al. (2009), (6) Carr et al. (2008), (7) Lequesne and Schroeder (1999), (8) Ernst (1988), (9) Kuzdrall (1992), (10) Stephens (2007)**

Noise category	Noise factor	Domain			Consistency		References
		M	E	S	Y	N	
Static characteristics	Reader position	x	x		x		(1)(2)(5)(6)(7)
	Scale resolution	x	x	x	x		(1)(2)(3)(5)
	Scale distortion	x			x		(1)(2)(3)(5)
	Eccentricity	x			x		(1)(2)(3)(5)(8)(10)
	Swash	x	x		x		(1)(2)(3)(5)
	Bearing wander	x				x	(1)(2)(3)(4)(5)
Insertion	Coupling	x	x			x	(1)(2)(4)
	Friction	x				x	(4)
Dynamic	Vibration	x	x			x	(1)(9)
	Bandwidth	x	x	x	x		(1)(4)(10)
	Wear	x	x				(1)(8)
Environmental	Temperature	x	x			x	(1)(7)(8)
	Pressure	x	x			x	(1)
	Contamination	x	x			x	(1)(6)(8)

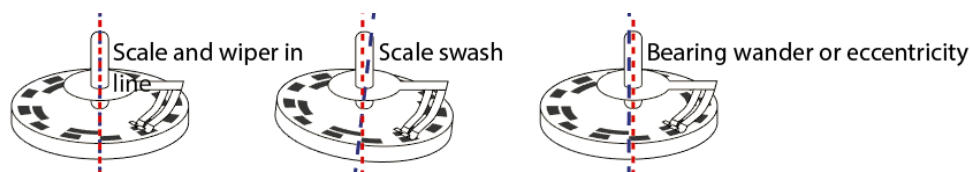

**Figure 3. Swash and eccentricity of reader and scale**

Bearing wander or axial run-out also compromises the position of scale and reader points in angular encoders (Ellin and Dolsak, 2008; Mancini et al., 1998). According to Qin et al. (2009) this bearing wander is not consistent and introduces a larger error than the *encoder itself*.

Ellin and Dolsak (2008) highlights the importance of the stiffness and consistency of the input coupling for the accuracy, which is an example of a noise factor introduced due to the insertion of the encoder into a mechanical device. Furthermore, Smith (1991) mentions how the side force should be kept at a relatively low ratio due to cross-axis sensitivity. The other insertion noise factor in Table 1, friction, is also highlighted by Smith (1991) as an influence disturbing the measuring performance of an integrated encoder.

### 3.3. Electromechanical trade-off example

One specific example of the dependency between the mechanical and electrical domains of the angular contact encoder is the design of the reader arms. In order to increase the signal-to-noise ratio the contact force should be maximised. However, increasing the contact force would lead to increased friction and hence increased disturbance of the rotation that the encoder is measuring. The trade-off between electrical signal quality and mechanical rotational friction is central for angular contact encoders and will be exemplified in this section.

The function of each reader arm is to act as a switch between different bit circuits. The current path is created through a surface contact between the reader arm and the scale pad and the signal strength is a

function of the contact force, because the current is constricted due to the roughness of the contact surfaces (Saitoh et al., 2007). When the contact force is increased, the surface asperities are deformed leading to an increase in the contact areas and hence a wider passage for the current.

Assuming straight, rectangular and slender reader arms for the sake of simplicity, the contact force can be calculated according to Equation (1):

$$F_c = \frac{3E_r I_y d_r}{l_r^3} \quad (1)$$

Where  $E_r$  [Pa] is the modulus of elasticity of the reader arm material,  $I_y = w_r t_r^3 / 12$  [m<sup>4</sup>] is the moment of inertia,  $d_r$  is the deflection of the reader arm and  $l_r$  [m] is the length of the reader arm. The dynamic frictional torque resulting from the contact force is defined by Equation (2):

$$T_\mu = \mu r_r F_c \quad (2)$$

The relationship between the electrical constriction resistance and contact force can be described by first assuming that the radius of the sum of asperity contact areas,  $r_a$  [m], can be described as a Hertzian contact as presented in Equation (3):

$$r_a = \left( \frac{3 F_c r_c}{4 E_{eff}} \right)^{1/3} \quad (3)$$

Where  $F_c$  [N] is the contact force,  $r_c$  [m] is the radius of the contact area and  $E_{eff}$  [Pa] is the effective modulus of elasticity of the interfacing surfaces as defined in Equation (4):

$$E_{eff} = \frac{E_r E_s}{(1 - \nu_r^2) E_s + (1 - \nu_s^2) E_r} \quad (4)$$

The Holm constriction resistance,  $R_c$  [ $\Omega$ ], is a function of the radius of the sum of asperity contact areas and the material resistivities as presented in Equation (5):

$$R_c = \frac{\rho_r + \rho_s}{4 r_a} \quad (5)$$

Where  $\rho_r$  and  $\rho_s$  [ $\Omega m$ ] are the bulk resistivities of the reader arm and the scale pad, respectively. The total electrical resistance also includes circuit bulk and film resistivities, but they are not considered here, because they are not related to the constriction resistance and contact force.

To illustrate the design trade-off between friction and constriction resistance, the sensitivity of the two objectives towards independent variation in dimensions and material properties are calculated. The advantage of using sensitivity as a measure of robustness is that the true variation ranges are not required and that the noise factors can be compared and prioritized in a simple manner (Frey and Patil, 2002; Göhler and Howard, 2015). However, it addresses only a small portion of the possible input ranges, does not include noise factor interactions and depends heavily on the arbitrarily chosen dimensional combination, because of the nonlinear nature of the equations (Frey and Patil, 2002). The relative nominal range sensitivities are calculated using Equation (6) (Göhler and Howard, 2015) with  $\Delta_i = 1\%$ .

$$NRS_i = \frac{\frac{f(x_i, \dots, x_i \cdot (1 + \Delta_i), \dots, x_n)}{f(X)} - 1}{\Delta_i} \quad (6)$$

As a reflection of Equations (1-5), the sensitivity of the constriction resistance towards independent variables are more distributed and hence smaller than for the frictional torque. However, the most influential parameters for both constriction resistance and frictional torque is the length and thickness of the reader arm. An increase in thickness decreases the resistance and increases the friction, which indicates that there is a conflict in assigning the reader arm thickness between the two objectives. The same applies to the length, but with opposite sign.

In Figure 4 the linear approximations of the influence of a 1% perturbation of the reader arm thickness on frictional torque and constriction resistance are plotted. The sensitivity i.e. slopes of the curves



have opposite signs highlighting the trade-off. The presented sensitivity analysis does not consider thresholds of the objectives. Hence, the severity of the trade-off and its effect on the sensor robustness has not been determined. On the other hand, the actual perturbations are not defined and therefore environmental and insertion noise factors are not excluded due to lack of exact knowledge about higher system levels and operational environments.

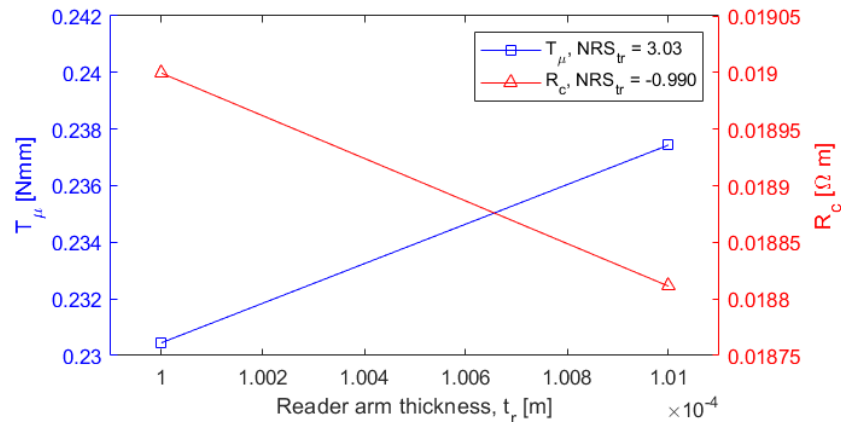

**Figure 4. Linear approximation of a 1% perturbation of the reader arm thickness on the frictional torque and the constriction resistance including sensitivities (see legend)**

An electromechanical trade-off is exemplified through the presented angular encoder case, but as mentioned in the literature review there are currently no methodology available to identify nor resolve cross-disciplinary trade-offs like this. The effect of the remaining mechanical influences for angular encoders listed in Table 1 as well as mechanical influences on other IoT sensors and devices are therefore also challenging to consider. As it has been shown that design trade-offs are indicators of robustness issues (Göhler and Howard, 2015) and early stage RDM for mechanical products focusses on achieving predictable product performance despite variation, it is proposed to extend the methodology into a cross-disciplinary domain.

#### 4. Currently available mitigation strategies

Despite the lack of approaches for early robustness assessment and design of sensor systems, different authors acknowledge the challenge and suggests basic strategies for mitigation of accuracy issues in encoders. These strategies include rules of thumb for the relation between scale resolution and the desired accuracy (Stephens, 2007; Ellin and Dolsak, 2008) as well as relative dimensions of the scale geometry (Lequesne and Schroeder, 1999). Mitigation strategies related to the mechanical domain include coupling of reader point positions (Carr et al., 2008), the use of multiple reader points to decrease the effect of eccentricity (Ellin and Dolsak, 2008; Macini et al., 1998) and contradicting statements about friction; Smith (1991) states that friction should be minimised due to the force and torque required to measure angular translation, which is in line with the static considerations presented in the case study, while Nyce (2016) states that friction is a means to improve damping and hence stability of a sensor. This trade-off highlights the need for consideration of both statics and dynamics in the embodiment.

Mitigation of electrical noise challenges include considerations of grounding (Stephens, 2007) and moving the average (Mancini et al., 1998; Stephens, 2007), which would directly increase the signal-to-noise ratio but also increase the power demand and responsivity (Carr et al., 2008).

In the software domain mitigation strategies include calibration of consistent variation such as eccentricity and swash (Ellin and Dolsak, 2008) as well as interpolation based on the scale pattern required due to vibration and edge noise (Kuzdrall, 1992). This requires that the pattern is known and that the output sequence is not compromised by multiple errors. An example of a well-established mitigation strategy targeting both reader point alignment errors and the possibility to interpolate is the configuration of the scale pattern in Gray code as opposed to natural binary (Nyce, 2016). The natural binary bit code is preferred by computers, but multiple bits change at the same time in the natural binary

sequence making it sensitive to alignment errors. The advantage of the Gray code is that only one bit changes at a time in the sequence, which mitigates discontinuity errors in case of angular misalignment.

## 5. Summary and discussion

In this paper the case of position sensors has been used to highlight the importance of mechanical design in the integration and design of sensors. This has been achieved by presenting an overview table of mechanical noise factors for angular encoders with indications of influenced domains and noise consistency (Table 1). Furthermore, a case example of the reader position in an angular contact encoder has been used to exemplify how a trade-off between a mechanical and an electrical design objective is created during the early design process (Figure 4).

The severity and constraints of trade-offs like the one presented in the example are important to consider during embodiment, why mechanical design and a cross-disciplinary robustness methodology should be integrated with the design of electronics and software. The review of current mitigation strategies stresses this claim as most modelling approaches and strategies are either complex or limited to specific domains. The one good example of an integrated mitigation strategy for encoders stresses the claim of concurrent mechatronic design of sensors.

Future work includes a generalisation of the combined effect of mechanical and electrical noise factors and mitigation strategies from angular encoders to other mechanical sensors as well as the impact of sensor robustness on IoT solutions. This starts with an investigation of how mechanical design is currently considered in electrical design and vice versa and aims at developing approaches for early evaluation of sensor robustness.

## Acknowledgments

The authors would like to thank Novo Nordisk for proving case study, insights and financial support to the DTU-NN Robust Design program.

## References

- Alyaqout, S.F., Papalambros, P.Y. and Ulsoy, A.G. (2010), "Combined robust design and robust control of an electric DC motor", *IEEE/ASME Transactions on Mechatronics*, Vol. 16 No. 3, pp. 574-582.
- Akbarzadeh, A., Kouravand, S. and Imani, B.M. (2012), "Robust design of a bimetallic micro thermal sensor using Taguchi method", *Journal of Optimization Theory and Applications*, Vol. 157 No. 1, pp. 188-198.
- Anadkat, N. and Rangachar, M. (2015), "Simulation based analysis of capacitive pressure sensor with COMSOL multiphysics", *International Journal of Engineering Research and Technology*, Vol. 4 No. 4, pp. 848-852.
- Arvidsson, M. and Gremyr, I. (2007), "Principles of robust design methodology", *Quality and Reliability International*, Vol. 24, No. 1. <https://doi.org/10.1002/qre.864>
- Bilel, N. et al. (2017), "Multi-objective robust design optimization of a mechatronic system with uncertain parameters, using a polynomial chaos expansion method", *Proceedings of the Institution of Mechanical Engineers, Part I: Journal of Systems and Control Engineering*, Vol. 231 No. 9, pp. 729-739.
- Carr, J. et al. (2008), "Miniaturised optical encoder", *Proc. SPIE 7068, Optical System Alignment and Tolerancing II, 70680M (2 September 2008)*, <https://doi.org/10.1117/12.793254>
- Carr, J.J. (1993), *Sensors and circuits: sensors, transducers, and supporting circuits for electronic instrumentation, measurement, and control*, PTR Prentice Hall, Englewood Cliffs.
- Chakrabarti, A. et al. (2011), *A tool for automated synthesis and side-effects detection in sensor designs*. Research Publishing, ISBN: 978-981-08-7721-7.
- Dumitrescu, R. et al. (2012), "Computer Support for the Identification of Solution Patterns for the Conceptual Design of Advanced Mechatronic Systems", In *ASME 2012 11th Biennial Conference on Engineering Systems Design and Analysis*, American Society of Mechanical Engineers Digital Collection, pp. 665-674.
- Egel, T. (2009), "Robust Design of Control Systems with Physical System Variances (No. 2009-01-1041)", *SAE Technical Paper*.
- Eifler, T. and Howard, T.J. (2018), "The importance of robust design methodology – case study of the infamous GM ignition switch recall", In *Research in Engineering Design*, Vol. 29, pp. 39-53. <https://doi.org/10.1007/s00163-017-0251-x>
- Ellin, A. and Dolsak, G. (2008), "The design and application of rotary encoders", *Sensor Review*, Vol. 28 No. 2, pp. 150-158, <https://doi.org/10.1108/02602280810856723>
- Eppinger, S. and Ulrich, K. (2015), *Product design and development*. McGraw-Hill Higher Education.

- Ernst, A. (1988), "Precise positioning with linear encoders", *Machine Design*, Vol. 60 No. 17, pp. 77-83.
- Forslund, A. and Galvez, A.V. (2011), "Virtual robustness evaluation of turbine structure assemblies using 3d scanner data", In *ASME 2011 International Mechanical Engineering Congress and Exposition*, American Society of Mechanical Engineers Digital Collection, pp. 157-165.
- Frey, H.C. and Patil, S.R. (2002), "Identification and review of sensitivity analysis methods", *Risk Analysis*, Vol. 22 No. 3.
- Göhler, S.M. and Howard, T.J. (2015), "The Contradiction Index (CI): A New Metric Combining System Complexity and Robustness for Early Design Stages", In *Proceedings of the ASME 2015 IDETC/CIE 2015*. [DETC2015-47255] American Society of Mechanical Engineers.
- Göhler, S.M., Eifler, T. and Howard, T.J. (2016), "Robustness metrics: consolidating the multiple approaches to quantify robustness", *Journal of Mechanical Design*, Vol. 138, [111407], <https://doi.org/10.1115/1.4034112>
- Janschek, K. (2011), *Mechatronic systems design: methods, models, concepts*, Springer Science & Business Media.
- Jugulum, R. and Frey, D.D. (2007), "Toward a taxonomy of concept designs for improved robustness", *Journal of Engineering Design*, Vol. 18 No. 2, pp. 139-156.
- Königseder, C. and Shea, K. (2014), "Systematic rule analysis of generative design grammars", *AI EDAM*, Vol. 28 No. 3, pp. 227-238.
- Kuzdrall, J.A. (1992), "Build an error-free encoder interface", *Electronic Design*, Vol. 40 No. 19, pp. 81-87.
- Lei, G. et al. (2017), "A review of design optimization methods for electrical machines", *Energies*, Vol. 10 No. 12, p. 1962.
- Lequesne, B. and Schroeder, T. (1999), "High-accuracy magnetic position encoder concept", *IEEE Transactions on Industry Applications*, Vol. 35 No. 3, pp. 568-576.
- Mancini, D. et al. (1998), "Encoder system design: strategies for error compensation", *Proc. SPIE 3351, Telescope Control Systems III*, <https://doi.org/10.1117/12.308835>
- Nerenst, T.B. et al. (2019), "Barriers for virtual assessment of structural robustness", *Proc. ASME 2019, IMECE2019*, Salt Lake City, USA.
- Nyce, D.S. (2016), *Position Sensors*, John Wiley & Sons, Inc. <https://doi.org/10.1002/9781119069164>
- Pahl, G. and Beitz, W. (1996), *Engineering Design: A Systematic Approach*, Springer, Berlin. <https://doi.org/10.1007/978-1-4471-3581-4>
- Pitney, K.E. and J.M. Ney Company (1973), *Ney contact manual*, J.M. Ney Company, Bloomfield, Conn., USA.
- Qin, S., Huang, Z. and Wang, X. (2009), "Optical angular encoder installation error measurement and calibration by ring laser gyroscope", *IEEE Transactions on instrumentation and measurement*, Vol. 59 No. 3, pp. 506-511.
- Saitoh, Y. et al. (2007), "Dependency of contact resistance on load", In *Electrical Contacts-2007 Proceedings of the 53rd IEEE Holm Conference on Electrical Contacts*, IEEE, pp. 70-75.
- Sarkar B. Chakrabarti A. and Ananthasuresh, G.K. (2015), "A new approach to conceptual design synthesis of sensors", In *Proceedings of the 3rd international conference design creativity*, Indian Institute of Science, Bangalore, pp. 192-199.
- Sarkar, B., Chakrabarti, A. and Ananthasuresh, G.K. (2017), "Synthesis of feedback-based design concepts for sensors", *Research in Engineering Design*, Vol. 28 No. 1, pp. 131-151.
- Smith, J.D. (1991), "Practical rotary encoder accuracy limits for transmission error measurement", *Proceedings of the Institution of Mechanical Engineers, Part C: Mechanical Engineering Science*, Vol. 205 No. 6, pp. 431-436.
- Stephens, A. (2007), "Addressing encoder error", *Motion Systems Design*, Vol. 49 No. 1, pp. 34-35.
- Taguchi, G., Chowdhury, S. and Wu, Y. (2005), *Taguchi's Quality Engineering Handbook*, Wiley & Sons, Inc.
- Torry-Smith, J.M., Mortensen, N.H. and Achiche, A. (2013a), "A proposal for a classification of product-related dependencies in development of mechatronic products", *Research in Engineering Design*, Vol. 25 No. 1, pp. 53-74.
- Torry-Smith, J.M. et al. (2013b), "Challenges in designing mechatronic systems", *Journal of Mechanical Design*, Vol. 135 No. 1, p. 011005.
- Villarreal-Cervantes, M.G. et al. (2012), "Robust structure-control design approach for mechatronic systems", *IEEE/ASME Transactions on Mechatronics*, Vol. 18 No. 5, pp. 1592-1601.