



Configuring System Products With CTO And ETO Components: Framework and Conceptual Modelling

Kourtis, Georgios Konstantinos; Hvam, Lars; Markworth Johnsen, Sara Helene

Published in:

Proceedings of the 11th International Conference on Customization and Personalization MCP 2024

Publication date:

2024

Document Version

Publisher's PDF, also known as Version of record

[Link back to DTU Orbit](#)

Citation (APA):

Kourtis, G. K., Hvam, L., & Markworth Johnsen, S. H. (2024). Configuring System Products With CTO And ETO Components: Framework and Conceptual Modelling. In Z. Anisic , & C. Forza (Eds.), *Proceedings of the 11th International Conference on Customization and Personalization MCP 2024: The Power of Customization and Personalization in the Digital Age* (pp. 152-160). University of Novi Sad.

General rights

Copyright and moral rights for the publications made accessible in the public portal are retained by the authors and/or other copyright owners and it is a condition of accessing publications that users recognise and abide by the legal requirements associated with these rights.

- Users may download and print one copy of any publication from the public portal for the purpose of private study or research.
- You may not further distribute the material or use it for any profit-making activity or commercial gain
- You may freely distribute the URL identifying the publication in the public portal

If you believe that this document breaches copyright please contact us providing details, and we will remove access to the work immediately and investigate your claim.

CONFIGURING SYSTEM PRODUCTS WITH CTO AND ETO COMPONENTS: FRAMEWORK AND CONCEPTUAL MODELLING

Georgios Konstantinos Kourtis, Lars Hvam, Sara Helene Markworth Johnsen
Danmarks Tekniske Universitet, Department of Civil and Mechanical Engineering, Kgs. Lyngby, Denmark

Abstract: *This article proposes an approach to configure system-products, encompassing both well-defined components (Configure-to-Order) and those requiring engineering (Engineer-to-Order components). While the configurator can't directly configure ETO components, it captures customer requirements for subsequent design. The configurator focuses on configuring CTO components, generating a list of requirements for both system products and ETO components. Based on literature a method for modeling a system including CTO and ETO products has been developed. The suggested method has been tested in an ETO company specializing in the manufacturing of Laser Systems, this model leverages the Product Variant Master (PVM) to incorporate system requirements such as Wavelength Range, Output Power, and Polarization Maintaining as well as requirements for the ETO components like Amplification Level, Fiber Doping. Besides this, the configurator includes solution space and constraints for configuring the CTO components like Amplifier Fiber Length, Wavelength Monitoring, Substrate Materials, etc. By combining CTO and ETO components in the configurator, the company obtains an overview of which components are needed in order to design the system-products, along with a complete list of requirements for system products and ETO components at an early stage. This enables a reduction in lead time and improvement in quality.*

Key Words: *Mass Customization, System-Products, Product Variant Master (PVM), Configuration of CTO/ ETO products, Configuration Strategies, Engineering Flexibility*

1. INTRODUCTION

As engineering companies increasingly adopt mass customization strategies, the need to effectively handle both Configure-to-Order (CTO) and Engineer-to-Order (ETO) products within the same organization becomes more pressing. Configurators, that are a crucial technology for supporting the mass customization in engineering companies, lead to benefits such as shorter

lead times, improved specification quality, fewer errors, reduced resource consumption, and enhanced product design as analyzed in Felfernig et al. (2014), Forza et al. (2006) and Hvam et al. (2008) articles. The modeling of configurators for CTO products has undergone extensive exploration, with a primary focus on retrieving, representing, and implementing relevant product information. Haug et al. (2012) approach, a prominent example, outlines a six-step process, albeit with variations depending on specific circumstances. These steps encompass elicitation, translation, formalization, documentation and finally the implementation, and synchronization in the configurator. The process for Engineer-to-Order products on the other hand remains less straightforward. Brière-Côté et al. (2010) introduced a method focusing on structured capture of customer requirements, integration of parameterized features, and accommodation of unique specifications. However, there has been limited attention given to modeling system-products that encompass both CTO and ETO elements simultaneously.

The concept of system-products, outlined by Chun-Che Huang et al. (1998), is explained as multiple interconnected components or subsystems designed to perform specific functions or achieve certain objectives. These components or subsystems may include mechanical, electrical, or software elements, and their interactions are essential for the overall functionality of the system as mentioned by Hvam (2006). System-products often involve various design phases, such as conceptual design, embodiment design, and detail design, where the layout, form, dimensions, and surface details of individual components are determined.

The main tool to characterize the level of configuration of the systems-products is the Customer Order Decoupling Point (CODP). Browne et al. (1996) mentioned that CODP can be characterized as the separation of decisions that are made under certainty from decisions that are made under uncertainty concerning customer demand. Four CODPs are most frequently used: Engineer-to-Order (ETO), Make-to-Order (MTO), Assemble-to-Order (ATO), and Make-to-Stock (MTS).

The further downstream the CODP is positioned, the more value-adding activities must be conducted under uncertainty (speculation), meaning the product specifications are not known until a customer order is received. Conversely, the further upstream the CODP is positioned, the more activities can be based on order commitment, i.e., certain information about product specifications is known in advance as Rudberg et al. (2004) explained. For example, MTS (Make-to-Stock) involves standard products where all specifications are known, and production is based on forecasted demand. In contrast, ETO (Engineer-to-Order) involves customized, unique products where specifications are unknown until a customer order is received. This distinction highlights the difference in certainty of information: MTS operates with high certainty and pre-defined specifications, while ETO operates with high uncertainty and bespoke specifications.

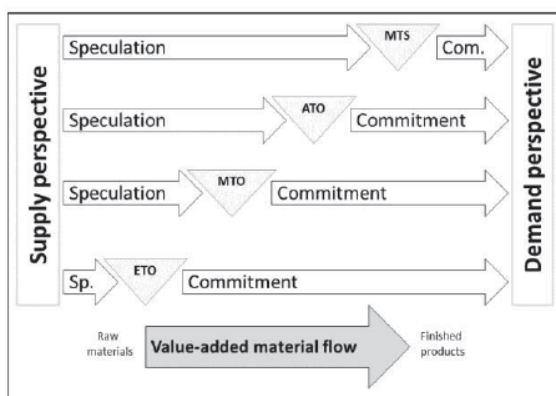

Fig. 1. The Customer Order Decoupling Point Concept as Rudberg et al. (2004) explained it

Another definition of the CODP comes from Hvam et al. (2008), where he explains it as the dividing line, where left of its specifications are developed independently of customer orders, typically for mass customization and standard components and on the right-hand side, specifications are tailored for individual orders, such as drawings and assembly instructions.

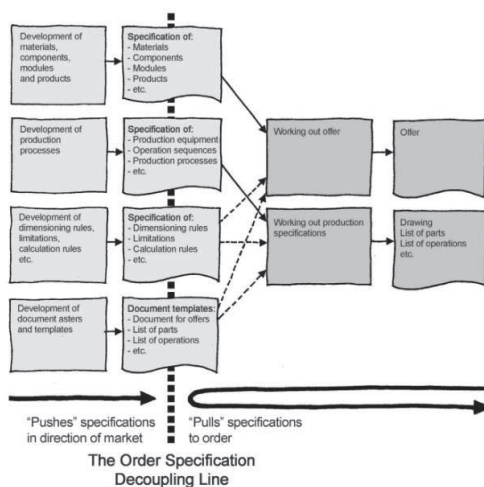

Fig. 2. The dividing line between specifications worked out on an order-initiated basis and specifications worked out independently of the individual orders based on Hvam et al. (2008)

Thus, when scoping configurators for CTO and ETO products, it is crucial to define the functionalities and requirements of the tool to accommodate these models effectively. For CTO, the configurator should facilitate streamlined selection based on the certain information mentioned, in conjunction with the ETO that it must adeptly handle uncertain information without compromising the final outcome.

A way to model Configure-to-Order (CTO) and in some cases Engineer-to-Order (ETO) products is through the Product Variant Master (PVM). The PVM model provides a rational and overall view of the product range's structure, including the product families and their variants based on Mortensen et al. (2010). This is achieved by representing the information from three dimensions: the customer, the engineering, and the part view and by been structured into two sections: one depicting the hierarchical generic structure, while the other represents variant alternatives.

In summary, while significant strides have been made in modeling configurators for both Configure-to-Order (CTO) and Engineer-to-Order (ETO) products individually, based on Forza et al. (2002) there remains a notable gap in addressing the complexities that arise when dealing with system-products that encompass components of both. This study addresses this challenge by introducing a framework that enhances and updates the Product Variant Master (PVM) model, utilizing the engineering view as a pivotal link between requirements defined in the Customer View and components in the Part view to be integrated in the final product. The objective is to create an overview of which components are needed in order to design the System-Products, along with a complete list of requirements for those system-products and the ETO components at an early stage.

So, the structure of this article unfolds as follows: Section 2 reviews the relevant literature that underpins the framework. Section 3 outlines the research methodology employed. In Section 4, the proposed model is presented, while Section 5 delves into the testing. Finally, Section 6 offers a discussion of the findings and concludes the study.

2. LITERATURE REVIEW

2.1. System-Products Overview

As mentioned in the introduction, System-products are entities composed of interrelated components or subsystems organized into a coherent structure. This ensample of components that may include mechanical, electrical, or software elements, is often represented by a Bill of Materials.

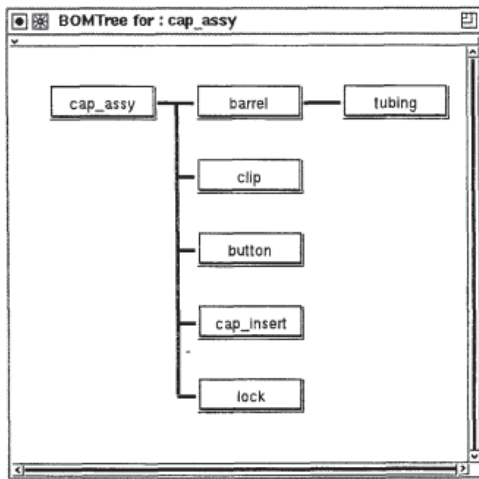

Fig. 3. A BOM tree example by Trappey et al. (1996)

The configuration of system-products involves defining a generic architecture that represents a product family, specifying component groups and their properties, and applying constraints to ensure feasible combinations. System-Products are particularly relevant in contexts requiring both Configure-To-Order (CTO) and Engineer-To-Order (ETO) strategies. While CTO focuses on pre-defined component selections to meet specific customer demands efficiently, ETO addresses bespoke customer requirements, necessitating significant customization and engineering effort according to Bonev et al. (2013) and Siddique et al. (2006).

2.2. Configuration Approaches for CTO/ETO Systems-Products

Configuration approaches can be understood through the lens of their respective processes and solution spaces. CTO (Configure-To-Order) involves specification processes characterized by a relatively closed solution space. This means that CTO products are defined by established rules and modules developed during the product development phase. These predefined elements facilitate routine activities such as planning, purchasing, production, assembly, and delivery. According to Schwarze et al. (1998), the specification of a customized product in a CTO environment relies heavily on the knowledge generated during the development of a product range. On the other hand, ETO (Engineer-To-Order) involves development processes with an open solution space, providing a high degree of creativity and flexibility.

Characteristics	Development	Specification
Degree of freedom	High	Low
New modules (components)	Yes	No (pre-defined)
Knowledge	Generated	Utilised/taken into consideration (not generated)
Type of activities	Creative	Routine
Closed-world-assumption	No	Yes

Fig. 4. Some characteristics of development and specification processes analyzed by Schwarze et al. (1998).

We can understand that integration of Configurators in Configure-To-Order (CTO) and Engineer-To-Order (ETO) contexts presents unique challenges and opportunities. Traditionally, Configurators are utilized in Make-To-Order (MTO) and CTO environments where a generic model encompassing all marketable products is pre-defined, facilitating rapid selection of solutions without additional engineering effort. Johnsen et al. (2017) analyzed that these "standard products" or "CTO products" are fully designed with evaluated performances, minimizing risks and feasibility issues. In contrast, fewer Configurators applications are reported in ETO contexts due to the restricted choice within standard offers and incomplete knowledge bases. However, recent frameworks have emerged to identify Configurator applications in ETO companies and support managers in effective Configurator implementation according to Kristjansdottir et al. (2017) and Cannas et al. (2022). These frameworks address the unique challenges ETO companies face and highlight the benefits of Configurators, such as improved efficiency and customization. Advances in models, methods, and tools for automatic configuration solution generation further support this integration. Johnsen et al. (2019) highlighted also in detail that an ETO System-Product can comprise both standard modules/parts (CTO components) as well as modified and entirely new modules/parts (MTO or ETO components).

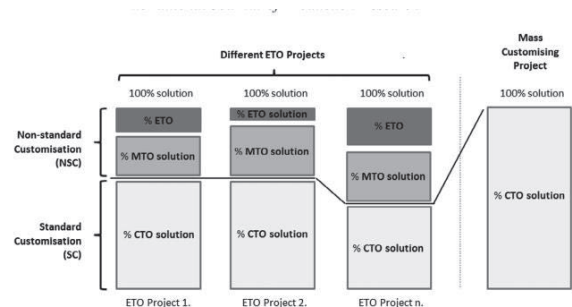

Fig. 5. Standard customization (SC) and Non-standard customization (NSC) according to Johnsen et al. (2019)

However, currently there is not a developed framework that combines the CTO and ETO components within a single Configurator, highlighting a significant gap and an area for future research and development.

2.3. The Product Variant Master Model

The Product Variant Master (PVM) Model is a technique for developing product platforms, offering a view of a company's product portfolio according to Hvam et al. (2008). The PVM model integrates object-oriented modeling, systems theory, and mechanical product modeling, making it highly adaptable for various industries. Known also as the Product Family Master Plan (PFMP), the PVM encompasses three dimensions: the customer view, engineering view, and part view. The customer view captures customer preferences, the engineering view details the functions and principles for configuring solutions, and the part view lists all physical components. The PVM is divided into a generic structure on the left, illustrating hierarchical object organization, and a variant structure on the right, describing object alternatives as Mortensen et al. (2010), Haug (2010); and Johnsen et al. (2019) analyzed in their articles. The engineering view is crucial, bridging customer specifications with technical requirements and connecting them with the part view.

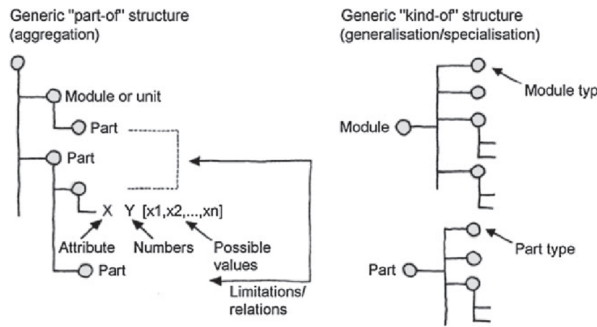

Fig. 6. Principles of the Product Variant Master explained by Mortensen et al. (2010)

3. RESEARCH METHOD

This paper aims to contribute to the literature on configurators and the integration of Configure-to-Order (CTO) and Engineer-to-Order (ETO) components by presenting a framework that addresses this issue. The proposed framework for modeling system products, which incorporates both CTO and ETO components, for modeling ETO and CTO products and theory for modeling System-Products. To validate the framework, it was tested within a company specializing in the design and manufacturing of laser System-Products.

3.1. Case Content

Our case company is a medium-sized Scandinavian company specializing in the development, manufacturing, and marketing of laser systems for various industries. This company was selected for its relevance to our research focus, as it configures system-products tailored to specific customer needs by either selling CTO system-products or combining both ETO and CTO components in an ETO context. The combinations of ETO and CTO components were configured manually and there was a need to find a framework to incorporate those combinations into the configurator.

Figure 7 illustrates the challenge in detail. Currently, ETO System-Products are handled manually without the use of a configurator. When an ETO laser system-product is integrated into another laser system-product, it becomes an ETO component, alongside the possible use of other ETO components in the same system.

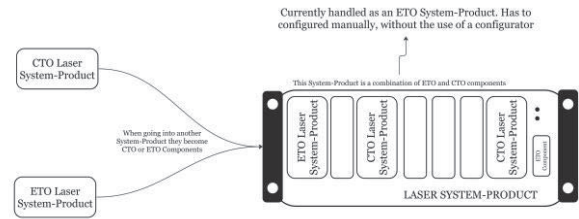

Fig. 7. Illustration of the current process for handling CTO and ETO system-products.

3.2. Data Collection and Analysis

To construct the framework for combining ETO and CTO components in the configurator, we conducted data collection through sessions with domain experts and by extracting data from the company's internal ERP system. Based on these sessions and the ERP data, we created the first draft of the PVM for the standardized products. We then explored different approaches to map the combinations of ETO and CTO components and translate them into the configurator.

The development of the framework was grounded in theoretical concepts related to product configuration and mass customization. Key theoretical foundations included the principles of modularity in product design, the Customer Order Decoupling Point (CODP) theory, and the Product Variant Master (PVM) model as presented in Hvam et al. (2008) and Mortensen et al. (2010) articles. By integrating these theories, we aimed to create a framework capable of handling the complexities associated with configuring both standardized and custom components within a single system.

These sessions were designed to gather detailed information about the product systems, including both standard and non-standard components. The data collection process involved:

- Interviews: Engaging with engineers, product managers, and other stakeholders to understand the configuration processes and the challenges associated with integrating CTO and ETO components.
- Document Analysis: Reviewing existing documentation, including product specifications and BOMs (Bill of Materials) from the ERP system.
- Observation: Observing the production and configuration processes to capture real-time data and validate information obtained from interviews and documents.

Based on the data collected, we mapped the process flow inside the Laser company for managing ETO and CTO system-products from initial customer contact to shipping. Figure 8 presents a simplified version of this process, focusing on the interactions between the salesperson and the product responsible engineer, and the use (or lack thereof) of the configurator.

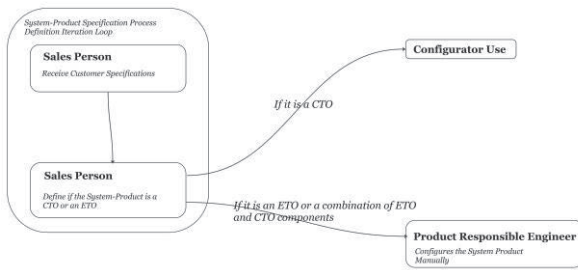

Fig. 8. Simplified Process Flow for Managing ETO and CTO System-Products

4. MODELLING APPROACH

In order to configure an ETO System-Product relevant to a customer's non-standard (Custom Requested) demand, different components, manufactured and purchased systems, standard and non-standard ones, must be assembled. A standard component is selected from the configuration model, without any additional effort. Whereas a non-standard (ETO) component is obtained whether by modifying an existing standard component or by adding a new component to the Bill of Materials (BOM).

Three different types of modification could happen.

1. Modifications of an existing purchased component of the system-product. In this case an ETO purchased component which has a non-standard value for at least one of its properties, is defined by modifying a standard purchased component. This modification can lead to different scenarios. First, modification is only required at the component and no additional modification is needed at the rest of the system-products BOM. Secondly, modifications are required to the component and at the rest of the system-products BOM as well.

2. Modifications on an existing manufactured component. In this case an ETO manufactured component which has a non-standard value for at least one of its properties, is defined by modifying a standard manufactured component. This modification can lead to different scenarios. First, the (engineering) modification is only related to the manufacturing process of the component. No additional modification is required to the BOM of the System-Product. Second, the (engineering) modification concerns the BOM of the system-product without any modification on the components manufacturing process. It's basically a non-standard integration of more than one standard component that have not been integrated together in the past.

3. Addition of a newly purchased or manufactured component. In this situation, an ETO component (a purchased or manufactured one) is defined by adding to the BOM of the system-product a new component that did not exist in the past. This (engineering) modification leads to modifications in the upper levels of the system-products BOM for its integration, and in some cases additional modifications might need to be made in the system-product in general.

We can categorize these modifications using the names pETO (Purchased Component Engineering-to-Order), mETO (Manufactured Component Engineering-to-Order), and nETO (New Component Engineering-to-Order) within the Product Variant Master (PVM). Also,

by using a combination of color-coding and symbols we can clearly visualize the scope of each modification. These notations will also highlight the connections between the engineering view, customer view, and production view. To further clarify these steps, we have illustrated the modification process in Figure 9. This flowchart visually represents the three types of modifications and their potential impacts on the system-product's BOM. To further clarify these modifications, we have illustrated the modification process in Figure 9. This flowchart visually represents the three types of modifications and their potential impacts on the system-product's BOM.

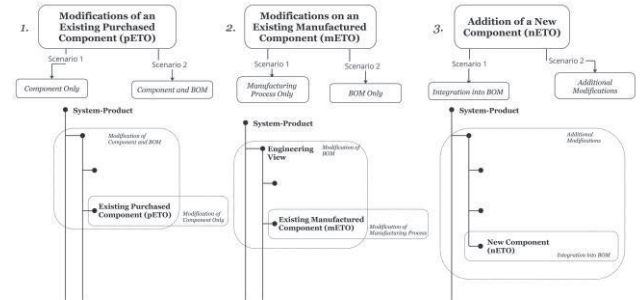

Fig. 9. Framework for integrating products with both CTO and ETO components in the configurator.

By following the importance of these notations into the PVM and incorporating them into the configurator, we can create an overview of which components are needed in order to design the system-products, along with a complete list of requirements for those system-products and the ETO components at an early stage.

Following this, a framework that maps out the necessary steps to integrate CTO and ETO components efficiently has been created. As depicted in the accompanying diagram (Fig. 10), is introduced. The process involves three main stages: establishing requirements, identifying ETO components, and documenting modifications. By systematically categorizing modifications into pETO (Purchased Component Engineering-to-Order), mETO (Manufactured Component Engineering-to-Order), and nETO (New Component Engineering-to-Order) and using visual cues for localized changes for propagated changes, we can clearly visualize the scope and impact of each modification.

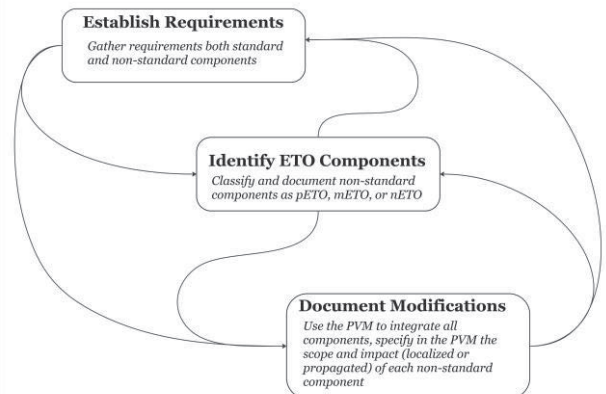

Fig. 10. Framework for integrating products with both CTO and ETO components in the configurator.

5 TEST CASE

5.1 PVM Modelling for System-Products that include both CTO and ETO components.

The Product Variant Master (PVM) was developed using a set of data collected from interviews with domain experts and analysis of existing documentation. This iterative process involved several stages including initial data collection, first draft creation, review and feedback, iteration and refinement, validation and finalization. The Product Variant Master (PVM), as previously described, builds upon the standard PVM, incorporating specific markers for ETO components. These components are categorized into pETO (Purchased Component Engineering-to-Order), mETO (Manufactured Component Engineering-to-Order), and nETO (New Component Engineering-to-Order). To enhance clarity and usability, we introduced visual indicators: blue circles denote modifications that affect only the current component (localized changes), and red arrows signify modifications that propagate and impact other parts of the product system's BOM (propagated changes). Each modification is accompanied by detailed descriptions explaining its impact on the overall system, providing a clear visual and textual guide to the changes. In Figure 11, we can see an example of the PVM model applied to a system-product that includes both CTO and ETO components, illustrating how these modifications are represented.

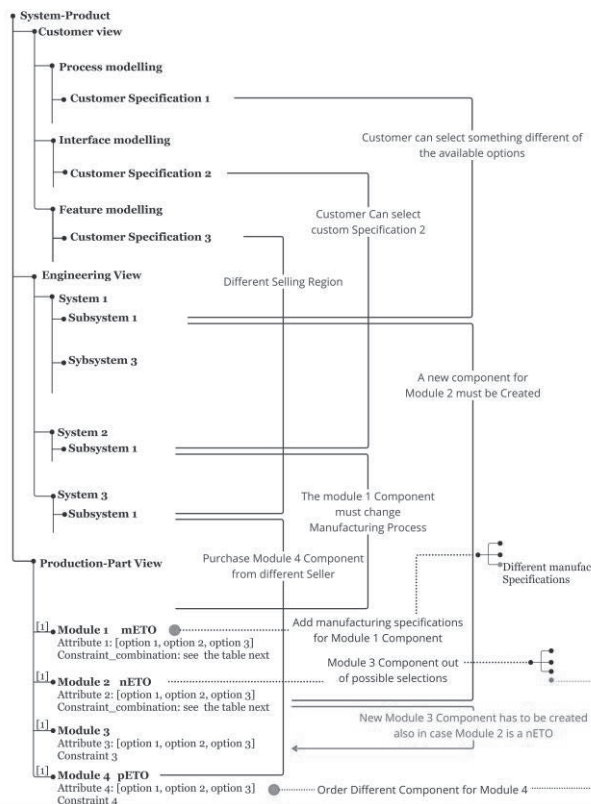

Fig. 11. PVM Model for System-Products that include both CTO and ETO components Example.

For this model to function effectively, it is essential that all component attributes and their corresponding specifications are documented. The engineering view

within the PVM is the most crucial view for this as it serves as the central connector between customer requirements and the physical components of the System-Product. It captures the specifications influenced by varying customer needs and translates these into actionable insights for the part view, subsequently affecting the BOM. The engineering view thus ensures that the company can identify necessary components early, maintaining a list of requirements for both system-products and ETO components. In Figure 12, we see an extract from each PVM view showing the Single Frequency Fiber Laser System, which includes both CTO and ETO components, highlighting how the engineering view integrates customer specifications with part details and in general how this model can be integrated into an actual product. To protect the company's proprietary information, some parts of the PVM and the names of the classes and attributes have been modified accordingly.

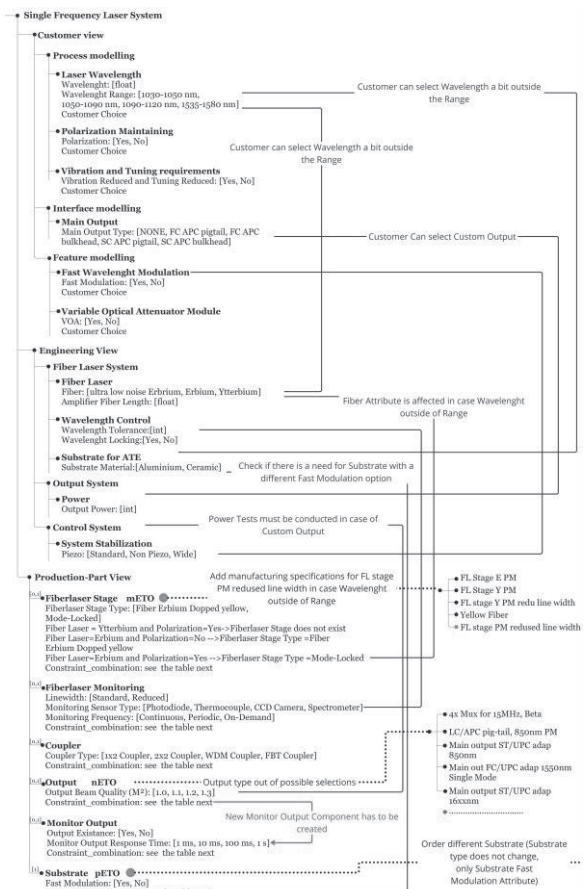

Fig. 12. Extract from each PVM's views showing the Single Frequency Fiber Laser System that includes both CTO and ETO components.

5.2 Evaluation of the PVM.

The Product Variant Master (PVM) was tested to ensure it accurately represents both CTO and ETO components. The testing focused on verifying data accuracy to ensure that the PVM contains up-to-date information on all components. It also involved checking the modification indicators, ensuring that blue circles and red arrows effectively denote localized and propagated changes, respectively. Additionally, there was a need to confirm that the PVM covers all possible component variations and their specifications, including new (nETO)

and modified (pETO, mETO) components. Finally, the integration aspect was evaluated to determine how well the PVM integrates with the configurator and vice versa.

5.3 Configurator Modelling for System-Products that include CTO and ETO components.

Creating a configurator that effectively integrates both Configure-to-Order (CTO) and Engineer-to-Order (ETO) components for system-products involves translating the information from the Product Variant Master (PVM) into the configurator. The process begins with capturing customer requirements, guiding customers to specify their needs for both standard and non-standard components. The configurator must be able to distinguish between requirements that lead to CTO or ETO components. For CTO components, the configurator should utilize the predefined database from the PVM, applying constraints and solution spaces to ensure feasible combinations. This step adheres to the design rules established in the PVM, allowing for the selection of standard components based on customer input. Handling ETO components requires the configurator to identify necessary modifications to existing components or the need for new components, based on the PVM's categorization into pETO, mETO, and nETO. For new components (nETO), the configurator should capture the required specifications and generate the necessary details. For remanufactured components (mETO), it should allow modifications that meet the customer's specific requirements. The configurator should support both fixed (closed) components and flexible (open) components that can be modified or added later. This approach ensures that the initial quote or BOM is 70-90% complete, with the flexibility to incorporate additional requirements and adjustments. By capturing and integrating these changes, the configurator ensures that new or modified components are accurately reflected in the overall BOM. In Figure 13, we can see a snapshot of the configurator for the Laser System. This interface includes an option for "CR Wavelength," indicating a Customer Requested Wavelength outside the standard scope of the configurator. In this case, if a customer specifies a CR Wavelength (that applies also to other customer specifications), the configurator generates all necessary components except for the Erbium Fiber component (SubBOM, it includes other subcomponents also), which is left empty. Upon generating the Bill of Materials (BOM), the placeholder for the erbium part is marked with "nETO" along with relevant specifications. This notation signifies that a new Erbium fiber component needs to be created, tailored to the specific requirements provided by the customer. The configurator thus ensures that while standard components are automatically configured, any new or custom components are clearly flagged and documented, enabling the engineering team to design these components according to precise customer specifications.

The screenshot shows the configurator interface for a Laser System. The 'Laser System' panel on the left contains the following fields and options:

- Wavelength:** System Selection: Erbium; Power (mW): 40mW; Wavelength Range: CR Requested Wavelength; Center wavelength (nm, in vacuum): 1550.2; CR Requested Wavelength: Yes (dropdown).
- Configuration:** Polarization Maintaining: No (dropdown); Fast Wavelength Modulation: No (dropdown); Main Output Type: Pigtail (dropdown); Monitor Output: Yes (dropdown); Monitor Output Type: FC-APC (dropdown); Pigtail length (m): 5 (dropdown); VOA: No (dropdown); Vibration reduced (tuning reduced): No (dropdown); Revision: 0.

The 'Parts List' panel on the right displays the following components:

- Erbium Fiber:** Fiberlaser Stage; FL Stage: FL Stage Non PM.
- Fiber:** Fiberlaser Monitoring; FL Monitoring: Non PM PD.
- Coupler:** Coupler Output; Output: 15xnm.
- Monitor Output:** Monitor Output: No monitor output (FC).
- Substrate:** Substrate: Substrate Aluminium non-PZT.
- Shell General Components:** Shell General Components: General Components.
- PatchC:** PatchC: PatchC PI 1550nm FC/APC.

Fig. 13. Screenshot of the configurator.

5.4 Evaluation of the Configurator.

The configurator was subjected to testing within a small part of the company. This demo was limited to a single system product and was not integrated with the company's ERP systems. As a result, the configurator was tested by a few people internally to evaluate the potential benefits of a future implementation within the ERP system. The testing activities involved multiple stages and participants:

Participants: The test group included engineers and product managers chosen for their in-depth knowledge of the product configuration processes and their roles in managing both CTO and ETO components.

Test Methodology: Participants were asked to perform two tasks using the configurator. These tasks included configuring a system product based on a set of predefined customer requirements, both standard and custom.

Assessment Criteria:

Ease of Use: Participants evaluated the intuitiveness of the configurator's interface.

Functionality Testing: The configurator's ability to accurately distinguish between CTO and ETO components and generate appropriate configurations was tested.

Error Handling: The response of the configurator to invalid or incomplete inputs was tested by intentionally providing incorrect or incomplete data.

Output Validation: The generated BOMs were reviewed to verify their accuracy and completeness.

Rough Results:

The testing activities yielded some rough insights into lead times, accuracy, and flexibility of the configurator. The results are summarized below, highlighting the improvements and challenges observed during the testing phase.

The lead time reduction was present across different types of components. For the combination of mETO and CTO Components, the configurator showed a remarkable improvement, with a reduction of $\approx 300\%$. This is due to the ease of integrating existing, out-of-scope components (mETOs) using the configurator, which contrasts sharply with the manual workarounds required by the current system. If pETOs were involved, the lead time reduction was around $\approx 80\%$. Adding new purchase items is simpler with the configurator, thanks to well-defined specifications, although it still requires some time. And

finally, if nETOs were involved also, for new ETO components specifically, the lead time reduction was about $\approx 20\%$. Designing new components naturally takes time, but the configurator's well-defined specifications contribute to some time savings.

Overall, the configurator reduces lead times, particularly for mETO and CTO components.

The configurator demonstrated a notable improvement in accuracy also. The accuracy of the configurator tested was approximately 95% even though it was just a demo Configurator, compared to the current system's 85-90% for the same BOMs. This enhanced accuracy could also lead to reduced lead times in future iterations, as fewer corrections would be needed.

Measuring flexibility quantitatively proved challenging, so we relied on participant feedback. Participants reported a general satisfaction with the configurator's flexibility in accommodating a wide range of requirements.

Those results were summarized in Table 1 below. In general, the results were very optimistic, so there is a need for more extensive real-world testing and integration with the company's current systems.

Table 1. Rough results measured during the testing of the demo configurator. The Lead Time rough results are in comparison the current company's systems

ETO Component Type	Lead Time Reduction	Accuracy	Flexibility Feedback
Current System	Baseline for comparison	$\approx 90\%$	N/A
Only mETO	$\approx 300\%$	$\approx 95\%$	satisfying
And pETO	$\approx 80\%$	$\approx 95\%$	satisfying
And nETO	$\approx 20\%$	$\approx 95\%$	satisfying

6 DISCUSSION AND CONCLUSIONS

The testing conducted provided insights into the effectiveness and potential of the configurator and the PVM in managing System-Products with both CTO and ETO components. Key findings included the configurator's ability to successfully distinguish between CTO and ETO components, accurately reflecting customer requirements in the generated BOMs. The system demonstrated flexibility in handling non-standard specifications, effectively marking placeholders for ETO components. Despite the lack of integration with the ERP system, the testing indicated benefits that could be realized with a fully integrated configurator. However, considerations for real-world implementation emerged. The demo was restricted to a single system product and was not connected to the ERP system, limiting the scope of the testing. Effective use of the configurator requires thorough training for users to understand the differences between CTO and ETO distinctions and the implications of their inputs. Future steps involve addressing the real-world implementation challenges through collaboration with stakeholders and iterative refinement.

The framework for the combination of ETO and CTO components in the configurator represents an advancement in product configuration, offering benefits

in flexibility, accuracy, and reduced lead time. It enables companies to handle a wider range of customer requirements with greater efficiency. By categorizing components and incorporating detailed specifications into the PVM, the configurator ensures that both standard and custom elements are managed. This level of integration is unprecedented, as traditional configurators typically handle only one type of component, either standard or custom, but not both simultaneously. Finally, this framework also addresses the challenges of real-world implementation by providing a clear path for integrating the CTO and ETO components together in the configurator.

7 REFERENCES

- Bonev, M., & Hvam, L. (2013). Performance measures for mass customization strategies in an ETO environment. In: *Proceedings of the 20th EurOMA Conference European Operations Management Association 6 July 2013, Dublin, Ireland*. European Operations Management Association.
- Brière-Côté, A., Rivest, L., & Desrochers, A. (2010) Adaptive generic product structure modelling for design reuse in engineer-to-order products. *Computers in Industry*. 61, (1), 53–65. Available from: doi: 10.1016/j.compind.2009.07.005.
- Browne, J., Harhen, J., & Shivnan, J. (1996) *Production Management Systems: An Integrated Perspective*. Addison-Wesley Publishing Company.
- Cannas, V. G. et al. (2022) Implementing configurators to enable mass customization in the Engineer-to-Order industry: a multiple case study research. *Production Planning and Control*. 33, (9–10), 974–994. Available from: doi: 10.1080/09537287.2020.1837941.
- Chun-Che Huang & Kusiak, A. (1998) Modularity in design of products and systems. *IEEE Transactions on Systems, Man, and Cybernetics - Part A: Systems and Humans*. 28, (1), 66–77. Available from: doi: 10.1109/3468.650323.
- Felfernig, A., Hotz, L., & Bagley, C. (2014) *Knowledge-Based Configuration From Research to Business Cases*. Elsevier Inc.
- Forza, C. & Salvador, F. (2002) Managing for variety in the order acquisition and fulfilment process: The contribution of product configuration systems. *International Journal of Production Economics*. 76, (1), 87–98. Available from: doi: 10.1016/S0925-5273(01)00157-8.
- Forza, C. & Salvador, F. (2006) *Product Information Management for Mass Customization*. London, Palgrave Macmillan UK.
- Haug, A. (2010) Managing diagrammatic models with different perspectives on product information. *Journal of Intelligent Manufacturing*. 21, (6), 811–822. Available from: doi: 10.1007/s10845-009-0257-y.

CORRESPONDENCE

Haug, A., Hvam, L., & Mortensen, N. H. (2012) Definition and evaluation of product configurator development strategies. *Computers in Industry*. 63, (5), 471–481. Available from: doi: 10.1016/j.compind.2012.02.001.

Hvam, L. (2006) Mass customization in the electronics industry: based on modular products and product configuration. *International Journal of Mass Customisation*. 1, (4), 410. Available from: doi: 10.1504/ijmassc.2006.010442.

Hvam, L., Mortensen, N. H., & Riis, J. (2008) *Product Customization*. Springer Berlin Heidelberg.

Johnsen, S. M. & Hvam, L. (2019) Understanding the impact of non-standard customisations in an engineer-to-order context: A case study. *International Journal of Production Research*. 57, (21), 6780–6794. Available from: doi: 10.1080/00207543.2018.1471239.

Johnsen, S.H., Kristjansdottir, K.H.; and Hvam, L.; (2017) Improving product configurability in ETO companies, In *Proceedings of the International Conference on Engineering Design, ICED, 21-25 August 2017, Vancouver, Canada*. Design Society pp 221-230.

Kristjansdottir, K., Shafiee, S., and Hvam, L. (2017) How to Identify Possible Applications of Product Configuration Systems in Engineer-to-Order Companies. *International Journal of Industrial Engineering and Management*. 8, (3), 157–165. Available from: doi: 10.24867/IJIEM-2017-3-116.

Mortensen, N. H., Hvam, L., & Haug, A. (2010). Modelling Product Families for Product Configuration Systems with Product Variant Master. In *19th European Conference on Artificial Intelligence (ECAI 2010)*

Rudberg, M. & Wikner, J. (2004) Mass customization in terms of the customer order decoupling point. *Production Planning and Control*. 15, (4), 445–458. Available from: doi: 10.1080/0953728042000238764.

Schwarze, S. & Schönsleben, P. (1998) Recent developments in the configuration of multiple-variant products: Application orientation and vagueness in customer requirements. In: *Advances in Production Management Systems*, pp. 243–254.

Siddique, Z. & Ninan, J. A. (2006) Modeling of modularity and scaling for integration of customer in design of engineer-to-order products. *Integrated Computer-Aided Engineering*. 13, (2), 133–148. Available from: doi: 10.3233/ICA-2006-13203.

Trappey, A.J.C., Peng, T.-K. & Lin, H.-D. (1996) An object-oriented bill of materials system for dynamic product management, *Journal of intelligent Manufacturing*. 7, 365-371. Available from: doi: 10.1007/BF00123912



Georgios Konstantinos Kourtis,
PhD Student
Danmarks Tekniske Universitet
Department of Civil and
Mechanical Engineering
Koppels Allé, 404, 221
2800 Kgs. Lyngby, Denmark
gkoko@dtu.dk



Lars Hvam, Professor
Danmarks Tekniske Universitet
Department of Civil and
Mechanical Engineering
Koppels Allé, 404, 213
2800 Kgs. Lyngby, Denmark
lahv@dtu.dk



Sara Helene Markworth Johnsen,
Senior R&D Process Engineering
Manager at NKT Photonics
NKT Photonics, Blokken 84, 3460
Birkerød, Denmark
sara.helene.markworth.johnsen@nktphotonics.com