



The acoustic center of laboratory standard microphones

Barrera Figueroa, Salvador; Rasmussen, Knud; Jacobsen, Finn

Published in:
Acoustical Society of America. Journal

Link to article, DOI:
[10.1121/1.2345830](https://doi.org/10.1121/1.2345830)

Publication date:
2006

Document Version
Publisher's PDF, also known as Version of record

[Link back to DTU Orbit](#)

Citation (APA):
Barrera Figueroa, S., Rasmussen, K., & Jacobsen, F. (2006). The acoustic center of laboratory standard microphones. *Acoustical Society of America. Journal*, 120(5), 2668-2675. <https://doi.org/10.1121/1.2345830>

General rights

Copyright and moral rights for the publications made accessible in the public portal are retained by the authors and/or other copyright owners and it is a condition of accessing publications that users recognise and abide by the legal requirements associated with these rights.

- Users may download and print one copy of any publication from the public portal for the purpose of private study or research.
- You may not further distribute the material or use it for any profit-making activity or commercial gain
- You may freely distribute the URL identifying the publication in the public portal

If you believe that this document breaches copyright please contact us providing details, and we will remove access to the work immediately and investigate your claim.

The acoustic center of laboratory standard microphones

Salvador Barrera-Figueroa^{a)} and Knud Rasmussen^{b)}

Danish Primary Laboratory for Acoustics, Danish Institute for Fundamental Metrology,
Matematiktorvet B307, DK-2800 Lyngby, Denmark

Finn Jacobsen^{c)}

Acoustic Technology, Ørsted-DTU Technical University of Denmark, Ørsted's Plads B352,
DK-2800 Lyngby, Denmark

(Received 25 December 2005; revised 1 August 2006; accepted 1 August 2006)

An experimental procedure is described for obtaining the effective acoustic distance between pairs of microphones coupled by a free field, leading to the determination of the position of the acoustic center of the microphones. The procedure, which is based on measuring the modulus of the electrical transfer impedance, has been applied to a large number of microphones. In all cases effects due to reflections from the walls of the anechoic chamber and the interference between the microphones have been removed using a time-selective technique. The procedure of determining the position of the acoustic center from the inverse distance law is analyzed. Experimental values of the acoustic center of laboratory standard microphones are presented, and numerical results obtained using the boundary element method supplement the experimental data. Estimated uncertainties are also presented. The results reported confirm values previously defined in an international standard and extend the frequency range. © 2006 Acoustical Society of America. [DOI: 10.1121/1.2345830]

PACS number(s): 43.38.Kb, 43.58.Vb., 43.20.Rz [AJZ]

Pages: 2668–2675

I. INTRODUCTION

The concept of acoustic center has been widely used in the development and practical realization of free-field reciprocity calibration of microphones.^{1–3} The acoustic center of a microphone is defined as follows: “For a sound emitting transducer, for a sinusoidal signal of given frequency and for a specified direction and distance, the point from which the approximately spherical wavefronts, as observed in a small region around the observation point, appear to diverge.”⁴ In the case of a reciprocal transducer such as the condenser microphone the acoustic center is the same whether the microphone is used as transmitter or receiver. This equivalence is explained by the fact that the diffracted field is equivalent to the radiated field when the radiating/diffracting object is acting in either condition.⁵

The accuracy of the position of the acoustic center as a function of the frequency has a significant influence on the accuracy of the estimated free-field sensitivity. However, only a few attempts to determine this quantity have been found in the literature. Most results have been determined from deviations of the amplitude of the sound pressure from the inverse-distance law, but there have also been a few examples of methods of determining the acoustic center from phase measurements. Jacobsen *et al.* summarized the literature and showed that the various procedures for determining the position of the acoustic center give in general different results for most sound sources, including condenser microphones.⁶

The position of the acoustic center of the microphones can be obtained from measurements of the acoustic transfer impedance between pairs of microphones. The measurement of the transfer function between the microphones is carried out in an anechoic room. However, any real anechoic room is less than perfect, and small reflections from the walls and interference between the microphones will contaminate the transfer function making the estimate of the acoustic center less accurate. The nature of these unwanted effects has been analyzed using statistical methods,⁷ and using time-selective procedures.⁸ Although time-selective methods can eliminate the unwanted contaminations, application of such methods may affect the accuracy of the estimated acoustic center. In this paper the time-selective technique described in Ref. 8 has been used for removing the unwanted reflections and interference between the microphones. The effect of the time-selective technique on the electrical transfer impedances used for determining the acoustic center is analyzed.

Prediction of the position of the acoustic center requires a precise knowledge of the sound field generated by the microphone when this acts either as a sound source or as a receiver. Thus a precise knowledge of the displacement of the diaphragm of the microphone and its geometry is needed. Some attempts to determine the sound field when a microphone is introduced in the propagation path of a plane wave have been described in the literature.^{9–13} However, these studies have been focused on obtaining the free-field correction of the microphone, except Ref. 11, which provided values of the position of the acoustic center of laboratory standard microphones of types LS1 and LS2 determined numerically using the boundary element method (BEM).

The purpose of this paper is to present and examine experimental values of the position of the acoustic center of

^{a)}Electronic mail: sbf@dfm.dtu.dk

^{b)}Electronic mail: kr@oersted.dtu.dk

^{c)}Electronic mail: fja@oersted.dtu.dk

laboratory standard microphones based on deviations from the inverse-distance law. The experimental results are supplemented with numerical results obtained using the BEM.

II. DETERMINING THE ACOUSTIC CENTER FROM THE INVERSE-DISTANCE LAW

The discussion may be simplified if the microphones are regarded as axisymmetric sources observed from positions on the axis of symmetry. Under this assumption, the acoustic center must be somewhere on the axis. If the amplitude of the sound pressure is plotted as a function of the distance, a straight line can be fitted over the region of concern. Thus, the position of the acoustic center, $x(k, r)$, can be determined using the following expression:⁶

$$x(k, r) = r + |p(r)| \frac{\partial |p(r)|}{\partial r}, \quad (1)$$

where k is the wave number, r is the axial distance from the diaphragm of the microphone, $p(r)$ is the sound pressure as a function of distance, and the rate of change, $\partial |p(r)| / \partial r$, must be estimated by any available means, for example by using least squares fitting.

The rate of change can be determined if measurements of the electrical transfer impedance are made at several distances. This procedure can be used when the characteristics of the air in the environment where the measurements are carried out can be calculated accurately using well defined standard procedures. The sound pressure generated by a microphone used as a sound source decreases as a function of the distance from the acoustic center, r_i , following the inverse-distance law,

$$p(r) = j \frac{\rho f}{2r_i} M_f \cdot i \cdot e^{-\gamma r_i}. \quad (2)$$

In Eq. (2) ρ is the density of air, M_f is the free-field sensitivity, f is the frequency, i is the current feeding the microphone, and γ is the complex propagation coefficient. This coefficient is defined as $\gamma = jk + \alpha$, where α is the air absorption. Thus, if an ideal receiver that does not disturb the propagating wave is located at a given distance, the output voltage will be inversely proportional to the true acoustic distance.

A realistic implementation of the above procedure must take account of the air absorption and the fact that the receiver will affect the sound field and will have its own acoustic center. In a reciprocity arrangement, the electrical transfer impedance between the microphones contains information about the position of the acoustic center of each microphone; therefore, it can be used for determining the sum of the acoustic centers of the two microphones. The electrical transfer impedance is defined as the ratio of the open-circuit voltage at the terminals of the receiver microphone, u_1 , to the current through the terminals of the transmitter microphone, i_2 ,⁴

$$Z_{e,12} \equiv \frac{u_1}{i_2} = j \frac{\rho f}{2r_i} \cdot M_{f,1} \cdot M_{f,2} \cdot e^{-\gamma r_i}. \quad (3)$$

In what follows the position of the acoustic center is defined as positive when the center is placed in front of the microphone diaphragm. Thus, the distance r_i in Eq. (3) is the difference obtained by subtracting the sum of the acoustic centers of the microphones, x_{1+2} , from the physical distance between the diaphragms of the microphones, r . Since only the modulus of the transfer impedance is of concern, it can be assumed that the parameters are independent of the distance. Substituting the true distance by its two components and rearranging terms gives

$$\frac{1}{|Z_{e,12}| e^{\alpha r_i}} \approx \frac{1}{A} (r - x_{1+2}) \approx mr + b. \quad (4)$$

Thus, the sum of the acoustic centers, x_{1+2} , can be obtained by dividing the independent term, b , by the slope, m . The slope corresponds to the rate of change defined by Eq. (1). Note that the procedure is based on the following assumptions: (i) The observation distance is long compared to the sum of the acoustic centers. Under typical measurement conditions, the distances range from 250 mm to 500 mm for LS1 microphones, and from 160 mm to 350 mm for LS2 microphones. According to values given in the standard, the acoustic centers are about 9 mm at low frequencies for LS1 microphones, and about 5 mm for LS2 microphones.⁴ (ii) The physical properties of the air inside the anechoic chamber can be estimated accurately using standard methods.^{4,14} (iii) In the range of distances where the measurements are made, the position of the acoustic center varies very little.¹⁵ The acoustic center determined by means of the above procedure is the average acoustic center at the average distance.

Typically, in a reciprocity measurement, the transfer impedance is measured using three microphones successively coupled in a free field. This yields three sums of acoustic centers of the three microphones. Thus, the position of the acoustic center of each microphone can be obtained by solving the resulting system of equations. The acoustic center of microphone No. 1 is

$$x_1 = \frac{b_{12}/m_{12} + b_{13}/m_{13} - b_{23}/m_{23}}{2}, \quad (5)$$

where $m_{i,j}$ and $b_{i,j}$ are the slope and the independent term determined for the combination between microphones i and j , respectively. Similar expressions can be obtained for the other microphones.

III. NUMERICAL MODELING

The procedures described above have been applied onto experimental data. However, since there are discrepancies between reported results, some source of validation is needed. No analytical solution of the scattering/radiation problem of the microphone exists, but several numerical formulations have been developed for solving the problem. Any of these formulations can be used for comparison with the experimental results. In this case, an axisymmetric formula-

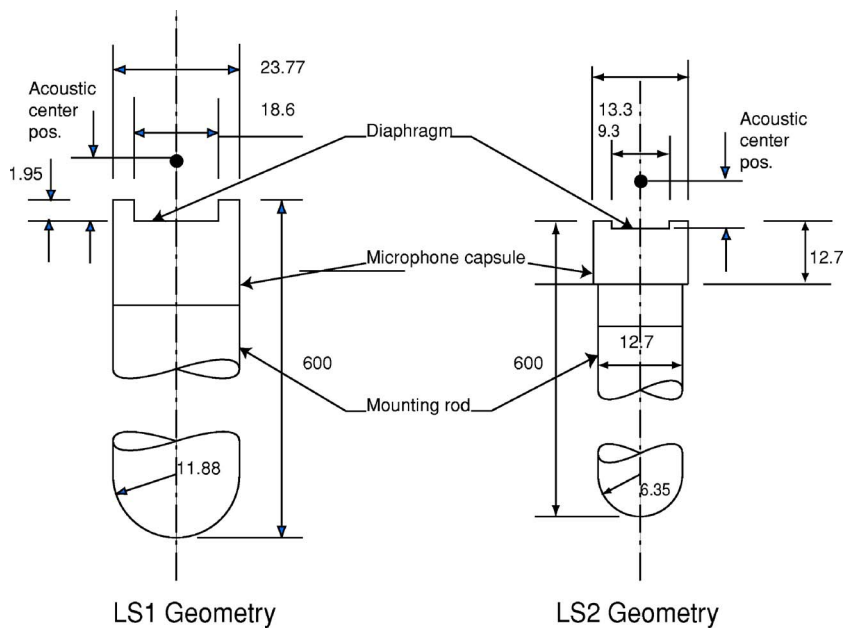

FIG. 1. Geometry of LS1 and LS2 microphones used in the BEM calculations. Dimensions in mm.

tion of the BEM (Ref. 11) is used for obtaining a numerical estimate of the position of the acoustic center.

This formulation was used by Juhl for determining the position of the acoustic center of laboratory standard microphones. Juhl's purpose was not to analyze the microphone problem in depth, but to validate his formulation with experimental data, and his low frequency approximation was based on the assumption that the movement of the diaphragm follows the first mode of the Bessel function of zero order and can be approximated by a parabolic function at frequencies below the resonance of the microphone. Under this assumption he calculated the position of the acoustic center up to 10 kHz. The assumption of the parabolic movement breaks down at higher frequencies where experimental results show significant deviations from the predicted values.

A modal sum of Bessel functions has been used extensively for describing the movement of the diaphragm.^{9,10,12,13,16-18} This has yielded some fairly good approximations in calculations of the free-field correction, but no calculation of the acoustic center based on these results has been made.

In this investigation it has been assumed that the displacement of a diaphragm of radius a under uniform pressure conditions is

$$\eta(r_D) = \left[\frac{J_0(k_D r_D)}{J_0(k_D a)} - 1 \right] \eta_0, \quad (6)$$

where J_0 is the Bessel function of zero order, η_0 is a constant that defines the amplitude of the movement, k_D is the wave number of the diaphragm, and r_D is the radial coordinate. A constant (pistonlike) displacement distribution has also been examined.

The geometry used in the simulations is shown in Fig. 1. The semi-infinite rod was approximated by a length of 60 cm. This will introduce a small disturbance in the results because of reflections from the back of the rod, but it is expected that the amplitude of this disturbance is negligible. The frequency range used in the calculations was

1 kHz–32 kHz for LS1 microphones and 4 kHz to 50 kHz for LS2 microphones. The size of the smallest element in the axisymmetric mesh was 2.5 mm and 1.5 mm for LS1 and LS2 microphones, respectively. Thus, there were at least four elements per wavelength at the highest frequency. It is well known that BEM solutions for exterior problems can be contaminated by spurious results associated with fictitious eigenfrequencies in the internal domain of the geometry.¹⁹ This is known as the nonuniqueness problem. In the case at hand this problem can occur above about 10 kHz. The nonuniqueness problem has been avoided by adding a random CHIEF point as described in Ref. 19 and further checked by calculating the condition numbers of the BEM matrices²⁰ and by repeating calculations with small frequency shifts.

IV. EXPERIMENTAL RESULTS

The positions of the acoustic centers of a number of condenser microphones of types LS1 and LS2 have been determined using the linear regression procedure outlined above. Equation (4) gives the sum of the acoustic centers of the two microphones of the measured pair. The individual values are determined using Eq. (5).

The measurements were made using the experimental apparatus described in Ref. 21. The measurement system consists of a homemade reciprocity apparatus which is connected to a Brüel & Kjær PULSE (B&K) analyzer; the receiver and transmitter microphone are connected to the reciprocity apparatus. The environmental conditions are measured and recorded during the measurement of the electrical transfer impedances; temperature and relative humidity are kept at $23^\circ \pm 0.5^\circ$ and $50\% \pm 10\%$, respectively, and the static pressure is $100 \text{ kPa} \pm 2 \text{ kPa}$. A simplified diagram of the measurement system is shown in Fig. 2. The determination of the acoustic center involves the measurement of the electrical transfer impedance of the three pairs of microphones at four different distances (24, 32, 40, and 48 cm for LS1 microphones, and 16, 20, 24, and 30 cm for LS2 micro-

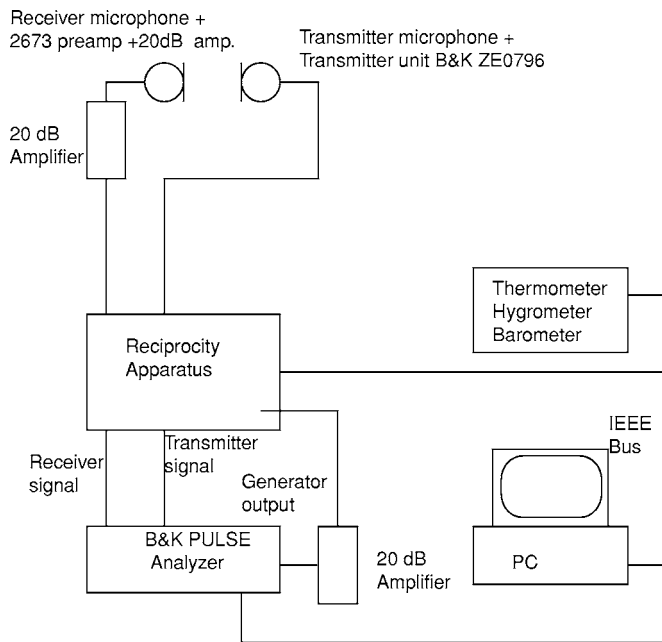

FIG. 2. Instrumentation used in the experimental determination of the acoustic center of Laboratory Standard Microphones.

phones), at discrete frequencies (from 1 kHz to 30 kHz for LS1 microphones, and from 3 kHz to 50 kHz for LS2 microphones) using stepped sine excitation with a frequency step of 120 Hz. The open-circuit voltage of the receiver microphone and the voltage on the terminals of the reference impedance connected in series with the transmitter microphone are measured using the B&K PULSE analyzer.

After some manipulations carried out onto the measured frequency response (described in Ref. 8), its associated impulse response is obtained by applying an inverse Fourier transform. The frequency step of 120 Hz is fine enough to obtain an impulse response that contains the primary reflections from the walls of the anechoic room and the interference between the microphones. These reflections are eliminated by applying a Tukey time-selective window with a duration of 1.8 ms for LS1 microphones and 1 ms for LS2 microphones. A direct Fourier transform is then applied to the time-windowed impulse response.

Once the influence of extraneous reflections from the walls and second-order interference between microphones have been removed from the measured electrical transfer impedance, the individual acoustic centers can be determined.

A. Effect of the time-selective procedure

Figure 3 shows a comparison between “cleaned” and “raw” estimates of the positions of acoustic centers of LS1 and LS2 microphones. Although the combined effect of cross-talk, interference between the microphones and reflections from the walls can be identified from the periodicity observed in the frequency domain, the identification of such effects is carried out more precisely in the time domain. A more detailed analysis can be found in Refs. 22 and 21. It is also clear that the time-selective procedure effectively removes much of the perturbations from the electrical transfer

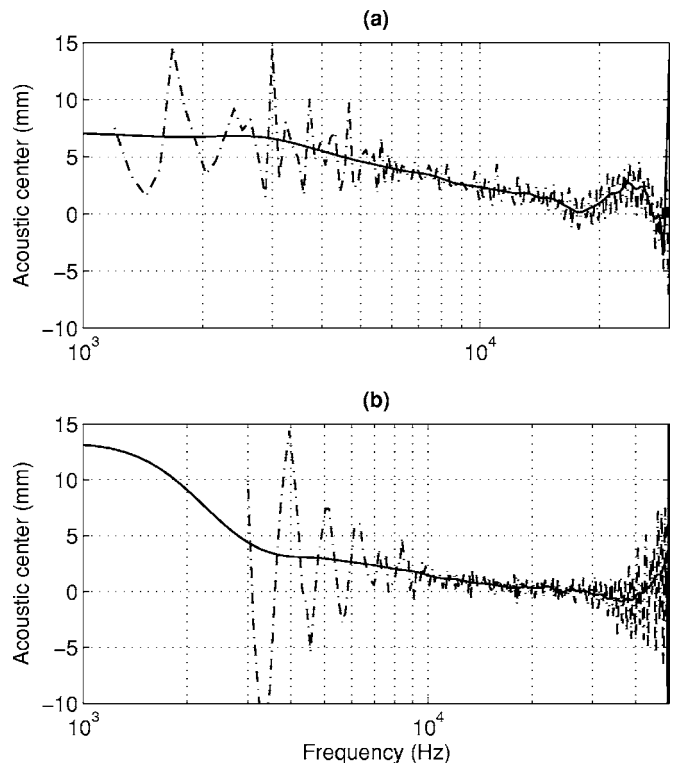

FIG. 3. Comparison between “cleaned” (solid line) and “raw” (dashed-dotted line) estimates of the position of the acoustic center for LS1 and LS2 microphones. (a) LS1 microphones (B&K 4160); (b) LS2 microphones (B&K 4180).

impedance and therefore from the estimate of the position of the acoustic center. The ripple observed at the extremes of the frequency range is caused by the time-selective window. Although this has a degrading influence on the estimated acoustic center, it seems to be preferable to the nonpredictable effect of the contaminations present in the raw estimate.

B. Average position of the acoustic center

Figure 4 shows the average acoustic center of LS1 and LS2 microphones (of 12 and 21 microphones, respectively) together with the standardized values.⁴ It can be seen that the position of the acoustic center of LS1 microphones more or less follows the standardized values of the acoustic center in most of the frequency range, but above 15 kHz and up to 20 kHz it seems to diverge. The acoustic center reaches a maximum about 26 kHz, and then decreases again. This behavior for LS1 microphones was also observed in one laboratory’s measurements in the international comparison,²³ although measurements were made only up to 25 kHz. The same tendency is observed for the LS2 microphones around 47 kHz. A similar behavior at high frequencies was registered for LS2 microphones in Ref. 7.

The frequency where the maximum occurs coincides with the frequency of the second radial resonance of the diaphragm. This suggests that the phenomenon may be related to the actual displacement of the diaphragm. This behavior will be compared with numerical BEM results.

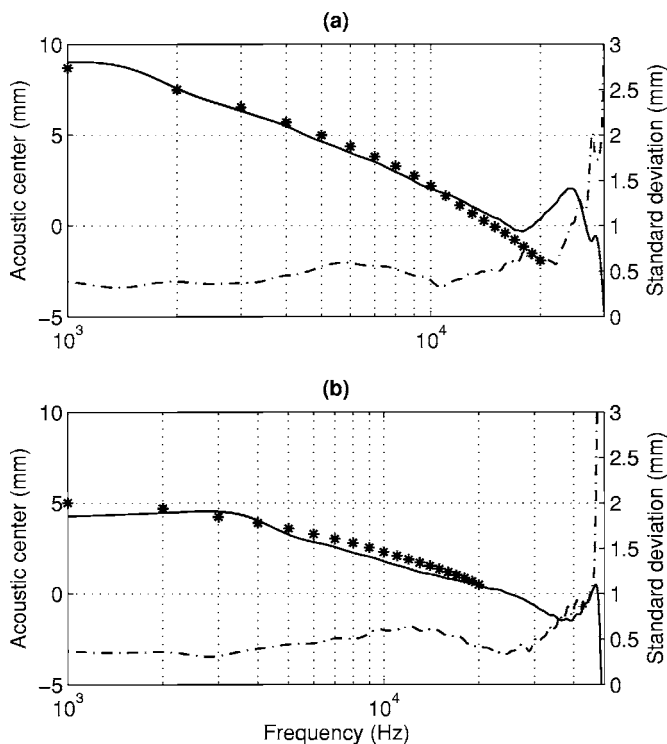

FIG. 4. Average position (solid line) and standard deviation (dashed-dotted line) of the acoustic center of a number of (a) LS1, and (b) LS2 microphones obtained experimentally. For comparison purposes, the standardized values are also included (stars).

V. NUMERICAL RESULTS

Figure 5(a) shows the results of the numerical calculations of the position of the acoustic center of LS1 microphones using the axisymmetric BEM formulation. It is interesting to note that the high frequency behavior of the calculated acoustic center resembles the experimental results. At low frequencies the assumed shapes of the displacement yield an acoustic center that follows the experimental estimate, although the uniform displacement distribution gives a slightly smaller value. It can also be seen that the calculated acoustic centers have a maximum at about the same frequency, which is the second radial resonance of the diaphragm. It is interesting to observe that in the frequency range where the peak is observed, it is the uniform distribution that shows the best agreement with the experimental values. This may be caused by the fact that at such high frequencies, the effect of the air film between the diaphragm and the back plate of the microphone begins to dampen the amplitude of the movement of the diaphragm, perhaps heavily, in the middle of the diaphragm, thus flattening the displacement distribution and making it look more like the uniform distribution. A similar behavior is observed in the case of LS2 microphones shown in Fig. 5(b). It should be interesting to have measured values of the actual velocity distribution of the diaphragm.

VI. DISCUSSION

An aspect of interest is the effect of the distance range in which the experimental acoustic centers are determined. This dependence has been demonstrated for some sources,⁶ and it

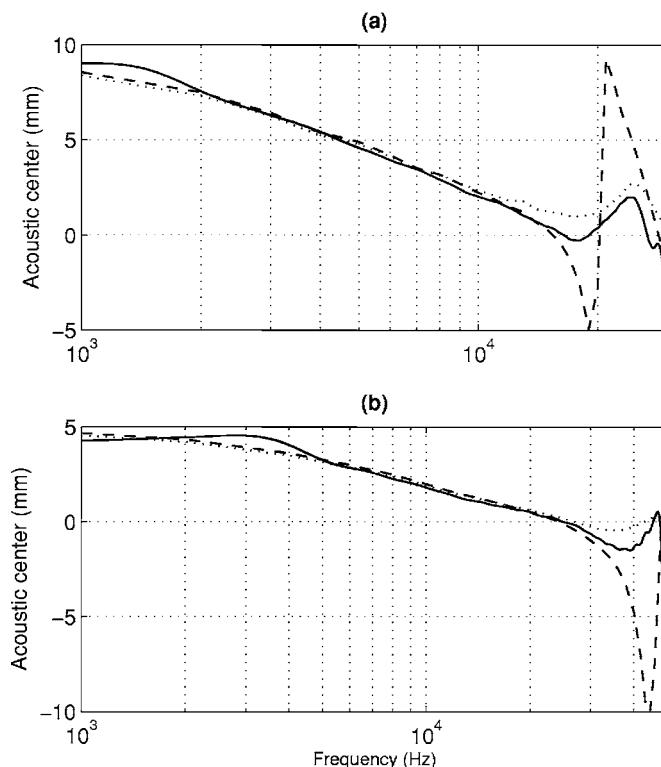

FIG. 5. Acoustic center of (a) LS1 and (b) LS2 microphones determined experimentally and numerically using BEM. Solid line, experimental results; dotted line, uniform distribution; dashed line, Bessel distribution.

would not be surprising to find a similar behavior in the case of the microphones.¹¹ Figure 6(a) shows the position of the acoustic center of LSI microphones calculated numerically at different average distances: 240 mm, 480 mm, and 1000 mm. It can be seen that there is a systematic influence of the distance on the position of the acoustic center. It should converge to a value at the largest distances, a far-field acoustic center. At low frequencies (below 1 kHz) the acoustic center converges slowly while above this frequency the convergence is faster.

Although it is very difficult to make reliable measurements of the electrical transfer impedance at large distances between the microphones because the signal to noise ratio is very poor, an experiment was carried out in order to estimate the effect of the distance on the estimated acoustic center. Figure 6(b) shows the experimental acoustic center at average distances of 260 mm and 380 mm. It can be seen that the acoustic center moves away from the microphone when the

TABLE I. Coefficients of the polynomial approximation of the acoustic center.

LS1	Coeff.	LS2
10.8	a_0	4.6
-2.32	a_1	-1.13
0.317	a_2	-0.052
-0.0268	a_3	0.0055
0.0011	a_4	-0.000224
$-1.64e-5$	a_5	$3.99e-6$
...	a_6	$-2.573e-8$

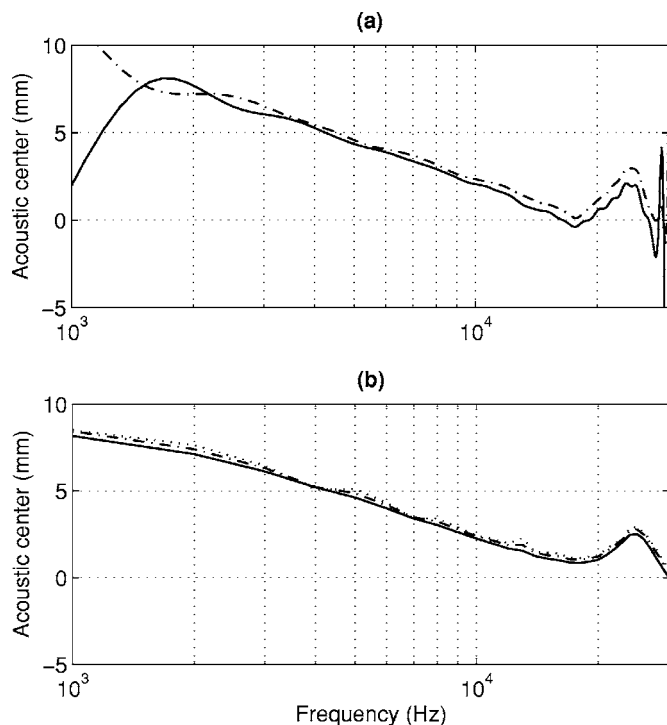

FIG. 6. Position of acoustic center of LS1 microphones obtained at different distances. (a) BEM results: Solid line, 240 mm; dashed-dotted line, 480 mm; and dotted line, 1000 mm. (b) Experimental values: Solid line, 260 mm; dashed-dotted line, 380 mm.

average distance is increased. It can be expected that the position of the acoustic center converges to a far-field value as the average distance increases, as observed in the numerical calculations.

The convergence to a far-field acoustic center leads to a discussion about which acoustic center should be used in free-field reciprocity calibration of microphones. An important consequence of the use of the acoustic center determined from modulus measurements is that the resulting free-field sensitivity becomes independent of the calibration distance.

Hence, if small changes in the acoustic center are introduced, this independence is degraded, and this will lead to changes in the free-field sensitivity. A change of 1 mm in the position of the acoustic center will lead to a change of 0.03 dB in sensitivity when the measurements are carried out at an average distance of 300 mm. One possibility would be to use the acoustic center determined experimentally, and to obtain a sensitivity that is valid for the distance range at which the measurements are made. Afterward, a correction could be made in order to obtain a far-field microphone sensitivity.

Because of the poor signal to noise ratio, it is very difficult to determine the position of the acoustic center experimentally at low frequencies and long distances. Additionally, the use of time-windowing will degrade the accuracy of the estimate of the acoustic center position at low frequencies. However, values of the acoustic center in the whole frequency range may be needed. One possible solution is to determine a polynomial approximation of the acoustic center that is obtained from experimental values at mid and high frequencies and from numerical values in the lowest frequency range.

If an accurate prediction of the acoustic centers at high frequencies using BEM is wanted, it is crucial to use a displacement distribution that represents the actual movement. Recent work suggests that a LASER vibrometer may be used to measure the displacement distribution.²⁴ This shape can subsequently be used to determine the acoustic center at frequencies where the displacement of the membrane is no longer described using simple functions.

Finally, as the position of the acoustic center of an individual microphone is not expected to change unless there is a significant change of the acoustic impedance of the microphone, any convenient choice of a polynomial approximation can be used advantageously instead of determining the experimental values every time. Coefficients of polynomial approximations of the experimental results are shown in Table I. These coefficients are used in the following polynomial:

TABLE II. Sources of uncertainty of the acoustic center for LS1 and LS2 microphones.

f (kHz)	LS1 microphones														
	1	2	3	4	5	10	15	20	25	26	27	28	29	30	
Voltage ratio (dB), Type A	0.035	0.026	0.017	0.009	0.009	0.009	0.009	0.009	0.009	0.009	0.009	0.017	0.026	0.035	
Cleaning technique (dB), Type B	0.146	0.026	0.009	0.002	0.002	0.002	0.002	0.002	0.002	0.002	0.002	0.009	0.026	0.146	
Air attenuation (dB), Type B	0.000	0.000	0.000	0.001	0.001	0.005	0.010	0.015	0.018	0.019	0.019	0.019	0.019	0.020	
Distance (mm), Type B	0.2	0.2	0.2	0.2	0.2	0.2	0.2	0.2	0.2	0.2	0.2	0.2	0.2	0.2	
Reproducibility (mm), Type A	0.39	0.41	0.33	0.43	0.53	0.37	0.44	0.63	0.76	0.71	0.84	1.7	1.2	1.8	
Far field (mm), Type B	0.2	0.2	0.2	0.2	0.2	0.2	0.2	0.2	0.2	0.2	0.2	0.2	0.2	0.2	
f (kHz)	LS2 microphones														
	1	2	3	4	5	10	20	30	40	45	46	47	48	49	50
Voltage ratio (dB), Type A	0.043	0.026	0.017	0.009	0.009	0.009	0.009	0.009	0.009	0.009	0.009	0.009	0.017	0.026	0.035
Cleaning technique (dB), Type B	0.206	0.026	0.017	0.013	0.007	0.001	0.001	0.001	0.001	0.001	0.007	0.013	0.017	0.026	0.206
Air attenuation (dB), Type B	0.0000	0.0000	0.0000	0.0001	0.0001	0.0004	0.0011	0.0014	0.0014	0.0015	0.0015	0.0015	0.0016	0.0016	0.0017
Distance (mm), Type B	0.2	0.2	0.2	0.2	0.2	0.2	0.2	0.2	0.2	0.2	0.2	0.2	0.2	0.2	0.2
Reproducibility (mm), Type A	0.32	0.3	0.31	0.38	0.44	0.6	0.4	0.44	0.66	0.85	0.9	1.05	2.6	2.6	2.6
Far field (mm), Type B	0.2	0.2	0.2	0.2	0.2	0.2	0.2	0.2	0.2	0.2	0.2	0.2	0.2	0.2	0.2

TABLE III. The position of the acoustic center and its uncertainty for LS1 microphones at selected frequencies.

f (kHz)	Ac. center (mm)	u (mm)	f (kHz)	Ac. center (mm)	u (mm)
1.0	9.01	5.6	16.0	0.14	0.6
2.0	7.56	1.5	17.0	-0.21	0.6
3.0	6.30	0.9	18.0	-0.28	0.7
4.0	5.43	0.6	19.0	-0.03	0.7
5.0	4.59	0.6	20.0	0.36	0.8
6.0	3.95	0.6	21.0	0.80	0.9
7.0	3.46	0.6	22.0	1.20	1.0
8.0	2.92	0.6	23.0	1.69	1.1
9.0	2.41	0.6	24.0	1.99	1.3
10.0	2.03	0.6	25.0	1.84	1.4
11.0	1.77	0.6	26.0	0.93	1.5
12.0	1.43	0.6	27.0	-0.33	1.7
13.0	1.03	0.6	28.0	-0.57	1.9
14.0	0.71	0.6	29.0	-1.07	2.5
15.0	0.44	0.6	30.0	-4.63	6.7

$$x(f) = a_0 + a_1f + a_2f^2 + \dots + a_n f^n, \quad (7)$$

where f is in kHz.

VII. CONCLUSIONS

The problem of determining the position of the acoustic centers of laboratory standard microphones has been addressed, and the acoustic center of laboratory standard microphones, LS1 and LS2, has been determined from the modulus of the electrical transfer impedance measured at different distances between pairs of microphones.

TABLE IV. The position of the acoustic center and its uncertainty for LS2 microphones at selected frequencies.

f (kHz)	Ac. center (mm)	u (mm)	f (kHz)	Ac. center (mm)	u (mm)
1.0	4.26	5.71	26.0	-0.09	0.58
2.0	4.44	1.83	27.0	-0.18	0.58
3.0	4.56	0.73	28.0	-0.33	0.58
4.0	4.04	0.62	29.0	-0.50	0.58
5.0	3.25	0.60	30.0	-0.64	0.58
6.0	2.84	0.62	31.0	-0.81	0.59
7.0	2.58	0.64	32.0	-0.92	0.60
8.0	2.26	0.66	33.0	-1.12	0.61
9.0	2.04	0.68	34.0	-1.20	0.63
10.0	1.80	0.70	35.0	-1.29	0.65
11.0	1.58	0.70	36.0	-1.45	0.69
12.0	1.38	0.70	37.0	-1.46	0.71
13.0	1.18	0.70	38.0	-1.44	0.73
14.0	1.08	0.69	39.0	-1.52	0.75
15.0	0.96	0.68	40.0	-1.37	0.75
16.0	0.84	0.66	41.0	-1.21	0.78
17.0	0.77	0.64	42.0	-1.15	0.81
18.0	0.66	0.62	43.0	-0.68	0.84
19.0	0.60	0.61	44.0	-0.58	0.87
20.0	0.51	0.60	45.0	-0.32	0.95
21.0	0.35	0.60	46.0	0.20	1.10
22.0	0.27	0.59	47.0	0.52	1.20
23.0	0.24	0.59	48.0	-0.75	2.90
24.0	0.12	0.59	49.0	-6.23	3.20
25.0	-0.01	0.59	50.0	-17.57	10.20

The position of the acoustic center has also been estimated using an axisymmetrical BEM formulation assuming different velocity distributions of the diaphragm. At low frequencies and up to the resonance frequency of the microphone, the use of simple functions such as the Bessel function yields values that are in good agreement with the experimental values. At higher frequencies the agreement degrades but the numerical results nevertheless confirm the experimental estimates.

There is a good agreement between the standardized and experimental values of the acoustic center in the mid-frequency range. The discrepancies observed at frequencies up to 20 kHz for LS1 microphones, and the need of sensitivity estimates at higher frequencies may point to the need of updating the standard. The experimental results presented in this paper may be regarded as a contribution to this process.

APPENDIX: TABULATED VALUES OF THE POSITION OF THE ACOUSTIC CENTER AND ASSOCIATED UNCERTAINTIES

The uncertainty of the estimate of the position of the acoustic center can be determined by following the ISO/GUM guide for estimating the uncertainty of measurements.²⁵ Equation (5) is the mathematical model used in the estimation of the uncertainties. The estimated slope and independent term are determined from transfer impedances “cleaned” from the influence of reflections and corrected for the effect of the air absorption. A list of the possible contributors is given below.

- 1. Electrical transfer impedance:** The modulus of the electric transfer impedance can be affected by many factors. The most conspicuous are the distance between microphones, the accuracy in the measurement of the voltage ratio, and the environmental conditions. The voltage ratio is measured using a steady state response (SSR) analyzer. This makes it possible to measure the frequency response with a given accuracy using a stepped sine excitation. The measurement is made using two channels in the same input range.
- 2. Time-selective technique:** The time-selective technique removes disturbances from the frequency response very effectively, but it also introduces ripples in the extremes of the frequency response. The ripple is caused by the fact that the time-selective window truncates the impulse response at positions where it is not zero. Thus, the ripple is a function of the length and position of the time window.
- 3. Microphone sensitivity:** The microphone free-field sensitivity may change slightly as a function of distance, but for the purpose of estimating the uncertainty of the position of the acoustic center of an individual microphone, it can be regarded as constant. However, in the uncertainty of the average position of the acoustic center of a number of microphones, deviations related to the geometry and acoustic impedance should be taken into account.
- 4. Air absorption:** The electrical transfer impedance is corrected for the losses induced by air absorption. This

is a function of some basic constants and the environmental conditions and the *physical* distance between the diaphragms of the microphones rather than the distance between acoustic centers. This is due to the fact that the acoustic waves actually propagate between the two diaphragms. The difference between using the physical distance and the acoustic distance is negligible in the frequency range of interest, though.

5. **Least-squares fitting:** The slope and the intercept are estimated using the least squares technique. These estimates have an associated standard error.

These contributors can be added to the model based on Eq. (5). Further simplification can be achieved by assuming that the value and uncertainty of each intercept and slope is the same. Thus, the mathematical model is

$$x_1(f) = \frac{b/m}{2} + R + \text{LS} + \text{FF}. \quad (\text{A1})$$

The least-squares fitting is made over the electrical transfer impedance measured at different distances. Each electrical transfer impedance is corrected for air absorption, thus $b, m = f\{Z_e, e^{ar}\}$, R is the reproducibility, LS is the contribution from the least-squares fitting, FF is the contribution due to the difference between the far field acoustic center and the acoustic center estimated at short distances between the pair of microphones; this quantity can be estimated experimentally or numerically as described in Sec. VI.

The uncertainty of the “cleaned” electrical transfer impedance measured at each distance can be estimated using a model that includes the effect of the measurement procedure, the time-selective technique, the distance, and the air absorption.

The uncertainty of the total absorption, which depends on the environmental conditions and the distance between the diaphragms of the microphones, can be estimated on the basis of the calculation procedure described in the standard,⁴ or the procedure described in a report that harmonized the calculation methodologies of the air properties used in the calibration of microphones.¹⁴ The analytical expressions can be difficult to differentiate, and a simplified procedure based on finite differences²⁵ has been applied instead. The uncertainty of the temperature, relative humidity, and static pressure is estimated to be 0.5°, 5%, and 50 Pa, respectively.

The inclusion of the reproducibility may result in overestimation of the uncertainty because it may contain the effect of factors already considered in the other contributors. However, as the present model does not include all the possible contributors, it is preferable to have a conservative estimate of the uncertainty of the acoustic center.

The contribution of the least squares fitting can be obtained using the estimate of the standard error. However, in this exercise, the correlation coefficient is always better than 0.99. Therefore, the standard error can be considered negligible. Table II shows the sources of uncertainty. Once the contribution of each element is established, the standard uncertainty of the acoustic center has been estimated using the procedures described in the ISO/GUM.

Table III gives values of the position of the acoustic center and their uncertainty for LS1 microphones at selected frequencies. Table IV lists the corresponding values of the acoustic center and its uncertainty for LS2 microphones.

¹W. R. MacLean, “Absolute measurement of sound without a primary standard,” *J. Acoust. Soc. Am.* **12**, 140–146 (1940).

²W. Wathen-Dunn, “On the reciprocity free-field calibration of microphones,” *J. Acoust. Soc. Am.* **21**, 542–546 (1949).

³I. Rudnick and M. N. Stein, “Reciprocity free-field calibration of microphones to 100 kc in air,” *J. Acoust. Soc. Am.* **20**, 818–825 (1948).

⁴IEC International Standard 61094-3, Measurement microphone Part 3: Primary method for free-field calibration of laboratory standard microphones by the reciprocity technique (1995).

⁵F. M. Wiener, “On the relation between the sound fields radiated and diffracted by plane obstacles,” *J. Acoust. Soc. Am.* **23**, 697–700 (1951).

⁶F. Jacobsen, S. Barrera-Figueroa, and K. Rasmussen, “A note on the concept of acoustic center,” *J. Acoust. Soc. Am.* **115**, 1468–1473 (2004).

⁷R.-P. Wagner and V. Nedzelnitsky, “Determination of acoustic center correction values for type LS2aP microphones at normal incidence,” *J. Acoust. Soc. Am.* **104**, 192–203 (1998).

⁸S. Barrera-Figueroa, K. Rasmussen, and F. Jacobsen, “A time-selective technique for free-field reciprocity calibration of condenser microphones,” *J. Acoust. Soc. Am.* **114**, 1467–1476 (2003).

⁹E. Matsui, “Free-field correction for laboratory standard microphones mounted in a semi-infinite rod,” *J. Acoust. Soc. Am.* **49**, 1475–1483 (1971).

¹⁰L. Bjørnø, O. Holst-Jensen, and S. Lolk, “Free-field corrections of condenser microphones,” *Acustica* **33**, 166–173 (1975).

¹¹P. M. Juhl, “A numerical investigation of standard condenser microphones,” *J. Sound Vib.* **177**, 433–446 (1994).

¹²R. Barham, “Free-field reciprocity calibration of laboratory standard microphones,” Ph.D. thesis, ISVR, University of Southampton, 1995.

¹³X. Bao and Y. Kagawa, “A simulation of condenser microphones by boundary element approach,” *J. Sound Vib.* **119**, 327–337 (1987).

¹⁴K. Rasmussen, “Calculation methods for the physical properties of air used in the calibration of microphones,” Technical Report, No. PL-11a, Department of Acoustic Technology, Technical University of Denmark, 1996.

¹⁵K. Rasmussen, “Acoustic centers of condenser microphones,” Technical Report, No. 5, The Acoustics Laboratory, Technical University of Denmark (1973).

¹⁶P. M. Juhl, “The boundary element method for sound field calculations,” Ph.D. thesis, The Acoustics Laboratory, Technical University of Denmark (1993).

¹⁷A. J. Zuckerwar, “Theoretical response of condenser microphones,” *J. Acoust. Soc. Am.* **64**, 1278–1285 (1978).

¹⁸Z. Skvor, *Vibrating Systems and their Equivalent Circuits* (Elsevier, New York, 1991).

¹⁹H. A. Schenck, “Improved integral formulation for acoustic radiation problems,” *J. Acoust. Soc. Am.* **44**, 45–58 (1968).

²⁰P. M. Juhl, F. Jacobsen, V. Cutanda, and S. Quiros-Alpera, “On the non-uniqueness problem in a 2-D half-space BEM formulation,” in *Proceedings of the Ninth International Congress on Sound and Vibration*, Orlando, FL (2002), cD-ROM.

²¹S. Barrera-Figueroa, “New methods for transducer calibration: Free-field reciprocity calibration of condenser microphones,” Ph.D. thesis, Ørsted-DTU, Technical University of Denmark, DK-2800 Kgs. Lyngby, Denmark, 2003.

²²S. Barrera-Figueroa, K. Rasmussen, F. Jacobsen, and L. Muniz, “On the interference between the two microphones in free-field reciprocity calibration,” *J. Acoust. Soc. Am.* **116**, 2771–2778 (2004).

²³K. Rasmussen and E. Sandermann-Olsen, “Intercomparison on free-field calibration of microphones,” Technical Report, No. PL-07, The Acoustics Laboratory, Technical University of Denmark, 1993.

²⁴G. Behler and M. Vorlander, “Reciprocal measurements on condenser microphones for quality control and absolute calibration,” *Acta. Acust. Acust.* **90**, 152–160 (2004).

²⁵BIPM, IEC, IFCC, ISO, IUPAC, IUPAP, and OIML, Guide to the expression of uncertainty in measurement (1995).