



The Tud C-band Sar

Skou, Niels; Madsen, Søren Nørvang; Christensen, Erik Lintz

Published in:
International Geoscience and Remote Sensing Symposium

Publication date:
1988

Document Version
Publisher's PDF, also known as Version of record

[Link back to DTU Orbit](#)

Citation (APA):
Skou, N., Madsen, S. N., & Christensen, E. L. (1988). The Tud C-band Sar. In *International Geoscience and Remote Sensing Symposium: Remote Sensing: Moving Toward the 21st Century* (Vol. Volumen 2, pp. 1039-1040). IEEE.

General rights

Copyright and moral rights for the publications made accessible in the public portal are retained by the authors and/or other copyright owners and it is a condition of accessing publications that users recognise and abide by the legal requirements associated with these rights.

- Users may download and print one copy of any publication from the public portal for the purpose of private study or research.
- You may not further distribute the material or use it for any profit-making activity or commercial gain
- You may freely distribute the URL identifying the publication in the public portal

If you believe that this document breaches copyright please contact us providing details, and we will remove access to the work immediately and investigate your claim.

THE TUD C-BAND SAR

N Skou, S N Madsen & E L Christensen

Electromagnetics Institute, Technical University of Denmark
Building 348, DK-2800 Lyngby, Denmark

ABSTRACT

At the Electromagnetics Institute, Technical University of Denmark, a C-band high resolution airborne SAR is presently being constructed. The radar uses digital pulse generation with a bandwidth beyond 100 MHz. This ensures large flexibility and a possibility to use predistorted codes to account for a non-perfect transfer function of the modulator and the up-converter. Pulse compression is also performed digitally. The radar data is pre-processed and dumped to a HDDT (high density digital tape) recorder, for later processing on off-line computers. A later phase of the project is concerned with constructing a real-time processor and a display facility to be carried with the radar in the aircraft. The calibration fidelity of the radar has been of great concern and this is reflected in the design in several ways: the analog parts of the radar are temperature stabilized, and several calibration loops are incorporated in the system.

The TUD C-band SAR is a single frequency system operating at 5.3 GHz. It is designed to obtain a resolution down to 2 m by 2 m. The maximum range of the system is 80 km and the swath width is between 10 and 50 km depending on the resolution. Both maximum range and swath width are prepared for later upgrading. The radar system is designed for installation in moderate sized jet aircraft. The system parameters are listed in Table 1 and the system block diagram is shown in Figure 1.

The basic pulse generation is carried out in the two channel, baseband digital pulse generator, consisting of code storage and D/A converters. This ensures excellent flexibility as the codes can be easily changed. Furthermore the codes can be predistorted to account for predicted or measured modulator/up-converter properties, so that the signal driving the TWT amplifier will be correct (important as the TWT is not operated in its linear region). The digital codes (up to 4096 samples long and each sample consist of 8 bit I and 8 bit Q data) are converted to analog signals at a 200 MHz sampling rate in dual D/A converters and the analog I and Q channels are transformed to a 300 MHz IF signal in the quadrature modulator. In the up-converter the signal is converted to 5.3 GHz and the signal is amplified to a level sufficient to drive the TWT tube (22 dBm). 100 MHz, 300 MHz and 5 GHz local oscillator signals are generated in a ref-

| | |
|-----------------------------------|-----------------------------|
| Frequency: | 5.3 GHz |
| Transmitter peak power: | 2 kW |
| Receiver noise figure: | 2.5 dB |
| Total system losses (estimated): | 3 dB |
| Pulse length: | from 0.64 to 20 μ s |
| Maximum bandwidth: | 100 MHz |
| Antenna gain: | 27 dB |
| azimuth beamwidth: | 2.7 ° |
| elevation pattern: | 40° section of cosec sqr. |
| polarization: | VV |
| Resolution range: | Variable 2, 4, 8 m |
| azimuth: | Variable 2, 4, 8 m |
| Slant range mapping width: | Variable 9.3, 21.6, 46.2 km |
| Range: | 80 km |

Table 1: System parameters

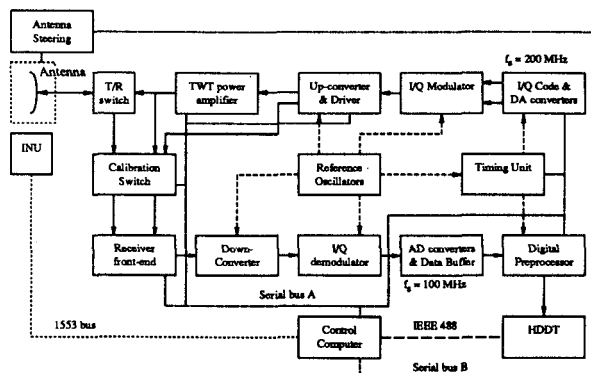

Figure 1: Block diagram.

ference oscillator unit, while 200 MHz is derived in the timing unit. Following the driver the signal is injected into the TWT power amplifier and a sample is directed into the Calibration Switch. The power level of the drive signal is controlled by a variable attenuator in a closed control loop. The power amplifier is a 2 kW Traveling Wave Tube amplifier with low phase noise. Following the TWT the signal is guided to the antenna.

Both the power level of the signal injected into the antenna, and the signal reflected from the antenna is monitored using a -60 dB cross coupler. The reflected signal will shut down the TWT Electronic Power Conditioner (EPC) if the level is excessive.

The slotted waveguide array antenna consist of four separate panels to provide large bandwidth. Seven waveguides are stacked in elevation and the elevation pattern is shaped to give a modified cosecant squared illumination over a 40° sector, with sidelobes suppressed 24 dB. This is of major importance to insure that reflections from fuselage and wings will not give rise to two-way propagation, and thereby interference fringes.

The received signal is, after passing a solid state receiver protection unit, amplified by a low noise amplifier with a noise figure of 2 dB, and following bandpass filtering a sensitivity time control (STC) is applied before the signal is down-converted to IF, thereby limiting the dynamic range already at the RF level. At the IF level the signal is bandlimited and then the signal is down-converted to video in a quadrature I/Q demodulator. The I and Q signals are digitized to 8 bits per channel in dual A/D converters running at a sampling rate of 100 MHz. The digitized echo is stretched to a high duty cycle signal in the data buffer, which holds 8192 complex samples, before the data flows into the digital preprocessor. The digital preprocessor performs Doppler tracking, initial motion compensation, and prefiltering of the data to reduce the effective pulse repetition frequency. A digital range filter that accepts complex data at a 100 MHz rate facilitating programmable low-pass filtering and downsampling is presently being developed and this filter will be inserted between the A/D converters and the buffers. Finally the signal is transferred to a HDDT system for later processing at the off-line facilities at the Institute.

The control computer monitors and controls the different units of the radar via the serial busses A and B. Also it interfaces with an Inertial Navigation Unit (INU) mounted close to the antenna. Based on the INU output it calculates motion compensation parameters used for antenna steering and processing corrections. Also the digital codes for the pulse generator are calculated in the control computer before being dumped to the code storage.

Calibration is a very important issue in modern remote sensing radars, especially when data from different radars or multi-temporal data from one sensor are to be compared or if measurements have to be compared to models. Several precautions are taken in the KRAS radar design to enable fairly accurate system calibration:

Thermal stability of the analog radar front end. It is well known within radiometer design (which represent microwave systems with calibration accuracies orders of magnitudes better than traditional radar designs) that proper thermal stability of the circuits is crucial. Hence the up-converter, the transmitter, and the receiver will be temperature stabilized to $40^{\circ}\text{C} \pm 1^{\circ}$.

Internal calibration loops. A sample of the signal to the antenna is via a calibration switch injected into the receiver. This signal propagates through the receiver, is A/D converted, and stored on the HDDT together with the echo signals to be observed a little later. Hence a true comparison is possible in the later analysis, resulting in nearly perfect calibration. This calibration scheme may prove difficult to achieve due to unwanted leakage from the power stages to the sensitive receiver stages. Several fall-back solutions has already been implemented. A sample of the TWT drive signal can be injected in the receiver. Right after transmission a second pulse is generated and not sent through the TWT but through the receiver like described above. This results in the TWT being outside the calibration loop, but as both the output power and energy is carefully measured for each pulse (and stored on the HDDT), a rather satisfactory calibration is also possible in this case.

Antenna calibration. It is well known within scatterometry, that with modern stable sensors the greatest uncertainty in backscatter measurements may often be attributed to insufficient knowledge of the antenna pattern. Hence accurate antenna measurements will be carried out using the spherical near field antenna measurement facility of the Electromagnetics Institute. A measurement accuracy better than 0.1 dB can be ensured.

Comparison with scatterometer. It is a generally accepted technique to enhance SAR calibration by comparison with accurate scatterometers during joint measurement campaigns. A very accurate C-band noise scatterometer has recently been developed at the Electromagnetics Institute [Skou, 1987] and this will be used for the said purpose.

The project status can be summarized as follows: the radar is in its construction and test phase. The receiver and the up-converter have been finished and have passed initial tests. The transmitter will be finished during summer 88. Major parts of the high speed digital hardware have been finished and tested. The antenna is designed and a test panel is being constructed. Installation in a Gulfstream G-3 aircraft of the Royal Danish Air Force is in its planning and design phase. The first flights are planned for summer 1989 collecting radar data on the HDDT for later ground processing. The next phase of the project includes real time processors and image display for installation in the aircraft. It is worth noting that the funds for this 2 year phase has already been secured.

ACKNOWLEDGEMENTS

The KRAS research programme is supported financially by the Thomas B. Thriges Foundation. The authors would also like to thank their colleagues A. Netterstrøm, K. Woelders and A. Østergaard for their contributions to the radar design.

REFERENCES

- Skou, N., 1987
A Very Accurate C-band Noise Scatterometer/Radiometer System,
Int. J. Remote Sensing, Vol. 8, No. 11.