



Fatigue testing of monostrands for stay cables under reversed cyclic flexural loading

Brand, Werner; Märzluft, Andreas; Fischer, Gregor; Georgakis, Christos

Published in:
fib Symposium Prague 2011

Publication date:
2011

[Link back to DTU Orbit](#)

Citation (APA):
Brand, W., Märzluft, A., Fischer, G., & Georgakis, C. (2011). Fatigue testing of monostrands for stay cables under reversed cyclic flexural loading. In *fib Symposium Prague 2011* <http://www.fib2011prague.eu/>

General rights

Copyright and moral rights for the publications made accessible in the public portal are retained by the authors and/or other copyright owners and it is a condition of accessing publications that users recognise and abide by the legal requirements associated with these rights.

- Users may download and print one copy of any publication from the public portal for the purpose of private study or research.
- You may not further distribute the material or use it for any profit-making activity or commercial gain
- You may freely distribute the URL identifying the publication in the public portal

If you believe that this document breaches copyright please contact us providing details, and we will remove access to the work immediately and investigate your claim.

FATIGUE TESTING OF MONOSTRANDS FOR STAY CABLES UNDER REVERSED CYCLIC FLEXURAL LOADING



**Werner
Brand**



**Andreas
Märzluft**



**Gregor
Fischer**



**Christos
Georgakis**

Abstract

The fatigue resistance of stay cables has been previously examined through axial loading of the stay cable assembly, with the anchorages attached and with an angular deviation of the anchorages in relation to the cable chord. However, this only represents a realistic load case if the relevant cable is not subject to any form of wind-induced or parametric excitation that can lead to bending vibrations. Even when introducing external damping or stiffening systems, wind-induced and parametric excitation of cables on bridges are quite common even if amplitudes often tend to be rather low. To realistically evaluate the fatigue lifetime of a cable, the assembly should therefore be tested by means of reversed cyclic flexural loading at a fixed axial load level.

In order to examine the differences in the fatigue resistance of mono-strands from different manufacturers and to vary the combination of static angular and reversed cyclic deviation, several tests have been performed on mono-strands. These strands were anchored in special mono-strand wedge anchorages with sealing units to simulate the same conditions as for type DYNA Grip[®] multistrand stay cable anchorages.

Keywords: Stay cables, Fatigue bending, Test method development, Service life aspects

1 Introduction

The fatigue design according to EN 1993-1-11 [1] for structures with tension components requires that flexural effects shall be considered. Protective measures to minimize the bending stresses within the anchorage areas shall be applied and the actual configuration used should preferably be tested. However there are no clear regulations on how this effectiveness should be demonstrated and how the bending stresses should be limited. Also *fib* Bulletin 30 [2] and Setra recommendations [3] give no values for limitation of the bending stresses.

A series of bending fatigue tests on galvanized, waxed and PE-coated 7-wire strands 0,62" with an ultimate tensile strength of 1860 N/mm² was performed and is reported on in this paper to demonstrate that the protective measures within the sealing unit of the DYNA Grip[®] are effective for fatigue bending without the additional use of a guiding device at the strand deviator.

2 Test Setup

At the Technical University of Denmark (DTU), a new test rig for single strand testing was designed. To simulate the strand deviation within a full size stay cable anchorage due to bundling effects and to consider static inclination of the cable to allow for construction tolerances, a test setup with static inclination at the anchorage was chosen. Like the recommended test setup according to fib Bulletin 30 [2], an S-shaped profile (**Fig. 1**) was used. To simulate the angular deviation of the cable due to cable vibration or structural deformation, transverse loading at midspan of the cable was created by means of a hydraulic actuator.

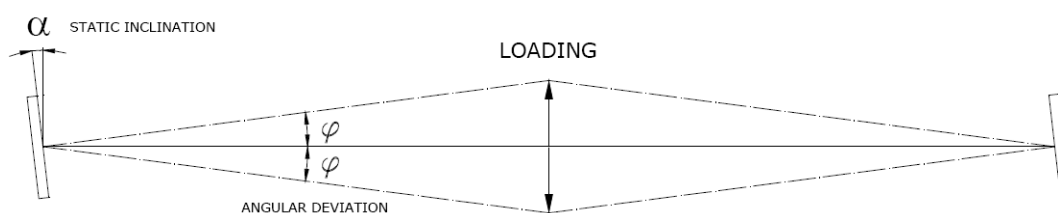

Fig. 1 Simplified model of a S-shaped setup with cyclic midspan deviation

A first test series conducted within the scope of a master thesis by Winkler and Kotas [4] was carried out on simple monostrand anchorages without any measure to reduce bending stresses (**Fig. 2**).

In a second test series, a specially designed monostrand anchorage including sealing device with bending filter and a long bore hole so that the PE-coated strand can penetrate into the steel anchorage (**Fig. 3**) as it is applied for the DYNA Grip[®] anchorage was used.

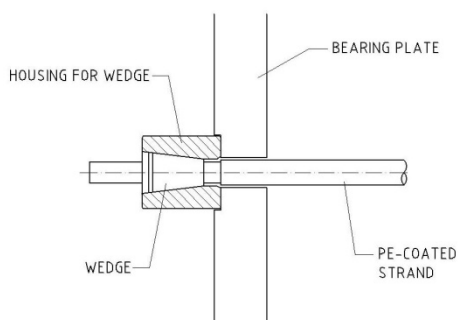

Fig. 2 Simple monostrand anchorage

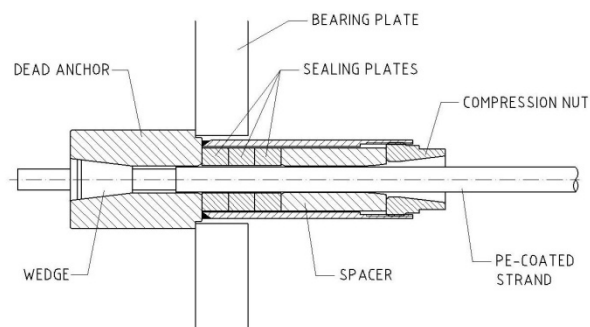

Fig. 3 Monostrand anchorage with sealing and bending filter

At the anchorages, static inclinations of $3,0^\circ$ were applied at the test rig and the single strand specimen was stressed to an axial force corresponding to 45% and 60% of the guaranteed ultimate tensile strength (GUTS), respectively. After stressing of the strand and power seating of both wedges, the additional angular deviation was varied from values between ± 10 mrad and 25 mrad in fatigue tests with up to 2×10^6 load cycles.

3 Test Results

In the test series with the simple anchorage (Fig. 2), wire fractures occurred at each of the nine tests already at a very early stage mostly between 10.000 and 20.000 cycles. The location of the fatigue failure was typically at the tip of the wedge (Fig. 4).



Fig. 4 Wire fracture at simple anchorage

In the second test series with the anchorage including the sealing device (Fig. 3), all of the 15 tests passed the 2×10^6 cycles without failure. Figure 5 shows the variation of axial strand force due to the transverse deviation of the strand. The initial loss of force can be explained with relaxation and wedge slippage, which stabilized after 500.000 cycles. As an additional output, the actuator load and actuator position were measured (Fig. 6).

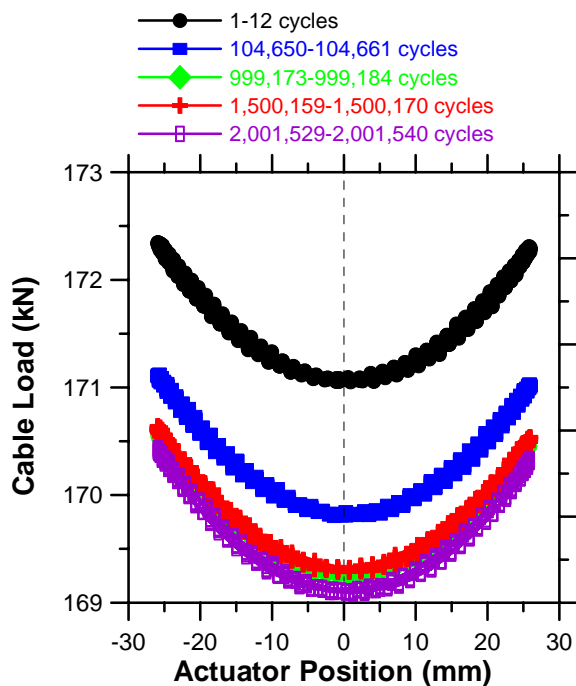

Fig. 5 Bending fatigue test with 3° static inclination at anchorage and ± 10 mrad angular rotation at midspan at 60% of ultimate load of strand.

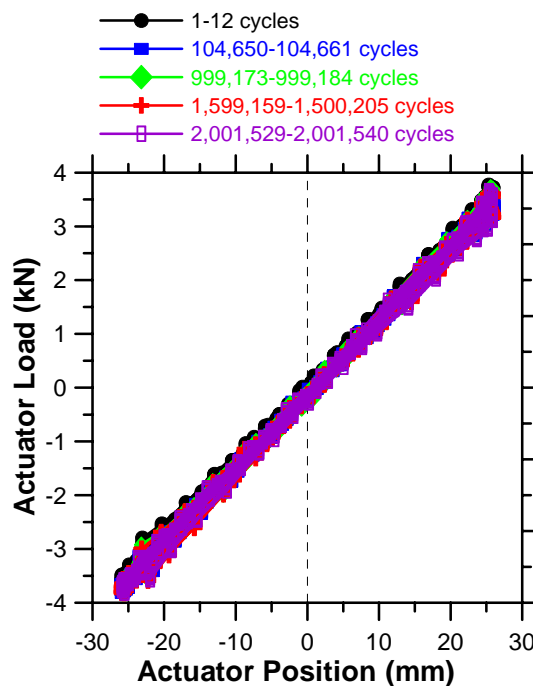

Fig. 6 Change of actuator load at midspan of strand during fatigue test.

4 Conclusions

The test results demonstrate that the use of ordinary wedge anchorages without any measure to reduce bending stresses at the anchorage is not sufficient for the use of stay cables which are exposed to fatigue bending.

A proper design of the anchorage comprising of a long guidance device of the PE-coated strand within the steel anchor block combined with the sealing device supporting the strand in transverse direction before entering the steel anchorage results in excellent fatigue bending performance of the DYNA Grip® stay cable system.

References

- [1] EN 1993-1-11: Eurocode 3 – Design of steel structures, Part 1.11: Design of structures with tension components, 2006
- [2] fib Bulletin 30: Acceptance of stay cable systems using prestressing steels, International Federation of Structural Concrete, Lausanne, Switzerland, 2005
- [3] SETRA: Cable Stays, Recommendations of French Interministerial Commission on Prestressing, Bagneux Cedex, France, 2002
- [4] J. Winkler, A. Kotas: Master Thesis, Fatigue Analysis of Steel Cables under Bending Load, DTU, Technical University of Denmark, 2010

Werner Brand, Dipl.-Ing.

✉ DYWIDAG-Systems International GmbH
Technical Service
Siemensstraße 8
85716 Unterschleißheim, Germany
☎ +49 89 30 90 50 177
📠 +49 89 30 90 50 170
😊 werner.brand@dywidag-systems.com
URL <http://www.dywidag-systems.com>

Andreas Märzluft, Dipl.-Ing. (FH)

✉ DYWIDAG-Systems International GmbH
Technical Service
Siemensstraße 8
85716 Unterschleißheim, Germany
☎ +49 89 30 90 50 108
📠 +49 89 30 90 50 170
😊 andreas.maerzluft@dywidag-systems.com
URL <http://www.dywidag-systems.com>

Gregor Fischer, PhD, Prof.

✉ Technical University of Denmark
Department of Civil Engineering
Building 118, Brovej
2800 Kgs. Lyngby
☎ +45 4525 5007
😊 gf@byg.dtu.dk
URL <http://www.byg.dtu.dk/>

Christos Georgakis, PhD, Prof.

✉ Technical University of Denmark
Department of Civil Engineering
Building 118, Brovej
2800 Kgs. Lyngby
☎ +45 4525 1949
📠 +45 51157478
😊 cg@byg.dtu.dk
URL <http://www.byg.dtu.dk/>