



CSMA-based SON Mechanism for Greening Heterogeneous Networks

Zakrzewska, Anna; Popovska Avramova, Andrijana; Ruepp, Sarah Renée; Berger, Michael Stübert; Dittmann, Lars

Publication date:
2013

[Link back to DTU Orbit](#)

Citation (APA):

Zakrzewska, A., Popovska Avramova, A., Ruepp, S. R., Berger, M. S., & Dittmann, L. (2013). *CSMA-based SON Mechanism for Greening Heterogeneous Networks*. Paper presented at 32nd IEEE International Conference on Computer Communications (INFOCOM 2013), Turin, Italy.

General rights

Copyright and moral rights for the publications made accessible in the public portal are retained by the authors and/or other copyright owners and it is a condition of accessing publications that users recognise and abide by the legal requirements associated with these rights.

- Users may download and print one copy of any publication from the public portal for the purpose of private study or research.
- You may not further distribute the material or use it for any profit-making activity or commercial gain
- You may freely distribute the URL identifying the publication in the public portal

If you believe that this document breaches copyright please contact us providing details, and we will remove access to the work immediately and investigate your claim.

CSMA-based SON Mechanism for Greening Heterogeneous Networks

Anna Zakrzewska, Andrijana Popovska Avramova, Sarah Ruepp, Michael S. Berger and Lars Dittmann

Department of Photonics Engineering

Technical University of Denmark

Ørstedes Plads 343, 2800 Kgs. Lyngby, Denmark

Email: {azak, apop, srru, msbe, ladit}@fotonik.dtu.dk

I. INTRODUCTION

Energy consumption has become one of the major challenges in the future communication networks. With the increased demand for capacity, the amount of energy needed by Radio Access Networks (RANs) grows significantly. Current research efforts propose solutions to increase network capacity at a much lower energy cost. For example in Distributed Base Station (DBS) or Cloud Radio Access Network (C-RAN), a set of Remote Radio Heads (RRHs) is connected to a baseband processing unit through an optical fiber which reduces the power needed to transmit the signal. Furthermore, thanks to centralized processing the number of sites decreases, thus network resources, including energy, can be better utilized through joint management. Another way to achieve this goal is deployment of low power nodes covering smaller areas than macro base stations, forming femto- or picocells. Even though small cells already reduce power consumption when compared to macro-sites, there is still room for improvement.

Base stations consume energy all the time, regardless of the traffic and the load. From an energy saving perspective, there is a high potential in reducing the transmission power when the resource utilization becomes low, as proposed in [1], [2]. However, this may be a challenging task in case of small cells, as they are deployed in an uncoordinated manner. Because of their dense deployment, centralized management is complex and introduces high signalling overhead. On the other hand, distributed decision taking process may lead to potential conflicts. In this work we present a method for independent decision spread and coordination among small cells based on Carrier Sense Multiple Access (CSMA) principles [3], and focus on an energy saving example.

II. SELF-ORGANIZING HETEROGENEOUS NETWORKS

Managing densely deployed small cells is a very challenging task and therefore Self-Organizing Network (SON) [4] has an enormous potential to make it easier, more automatic and thus reduce the cost of network maintenance and operation.

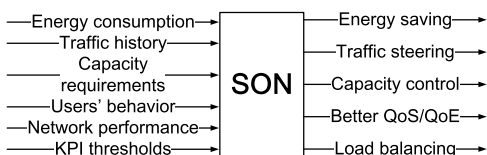

Fig. 1. SON input and output

Fig. 1 presents a general view on SON. It automatically collects different type of network information from neighbouring cells, such as current network performance (e.g. traffic load and resource utilization for macro and pico layer, as well as energy consumption). This data is used for further analysis, comparison with previous records, such as traffic history for instance, preparation of future prognosis and finally execution of optimization tasks. As a result, network performance can be improved according to the required Key Performance Indicators (KPIs) thresholds, e.g. load, utilization and energy consumption limits.

SON can help to manage the dynamic wireless environment made out of small cells in either a centralized or distributed way. In the first case, there is an entity responsible for collecting the data, performing optimization tasks and enforcing the decisions. On the contrary, in the latter scenario every cell runs its own optimization procedures based on the information gathered from the surrounding environment (through sensing, reports from the neighbours etc.). Every low power node should then implement changes on its own but at the same time be aware of the configuration updates introduced at the neighbouring cells, as it may influence its own performance and decisions. In this work we focus on the distributed scenario and propose a mechanism based on CSMA to coordinate such an independent parameter change.

III. ENERGY EFFICIENCY

As mentioned in the introductory section, base stations consume the same amount of energy when being idle e.g. at night, as they do during peak traffic hours. The same applies to small cells but it is easier to mitigate than in the case of macro base stations. Low power nodes have more local character and their coverage is much smaller. Therefore, it is easier to adjust their power or even switch them off without a risk of causing a coverage hole, as there is always overlaying macrocell providing the service.

There are various modes of operation of small cells, namely open, close and hybrid subscriber group (OSG, CSG and HSG, respectively) [5]. Depending on the user activity, the transmission power of a small cell may be significantly reduced for enterprise open cells when the load is low or more private CSG cells may be even put into the sleep mode during night hours. To facilitate such changes we introduce 3 power levels: 1) regular when a node serves users at a maximum allowed power level, 2) reduced power, when a node operates at a lower power and hence the cell has smaller coverage, and 3) sleep mode,

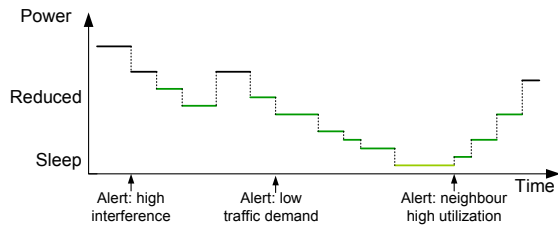

Fig. 2. Gradual power control

when a node is available for control communication purposes but does not provide any service to the users. Different kind of alerts (internal or coming from the neighbours) can enforce reduction or increase of the transmission power of a cell, as presented in Fig. 2. For example, constant decrease of traffic demand in a cell may eventually put a node into the sleep mode. Any users that need to be served in the primary small cell coverage area can be redirected by an enforced handover either to the umbrella macrocell or to a neighbouring small cell, if the latter increases its coverage. On the other hand, an alert on high utilization of neighbouring nodes, which may lead to traffic congestion, will wake up a node and make it fully operational. We note that changes of the node transmission power can be done gradually on a step-by-step basis, and the value intervals as well as the frequency of such changes depend on the implemented algorithm.

IV. CONTROL MECHANISM

In a dense small cell environment, where SON functionalities are distributed, each small cell has its own optimization object. In Fig. 3 several small cell objects and the communication among them are illustrated.

In the time domain, we illustrate the optimization procedure as consisting of the following time periods: sensing and reporting, decision making, action execution and frozen period. During the overall operation, each cell needs to continuously monitor the environment, and inform the neighbouring cells of its current state. The actual intervals for reporting and alerting depend on many parameters such as current load, the time of the day, expected traffic demands, power consumption etc. If the measured KPIs get closer to the actual thresholds, the alerting interval could be reduced. If the KPI thresholds are violated then the optimization procedure needs to reach a decision that will eventually result into an action (e.g. change of transmission power, antenna tilting). For example the gradual power control explained in Fig. 2 of the previous section represents the decision period.

The question of who should perform an action among the neighbouring cell is resolved as in CSMA with collision avoidance (CA) scheme. Before an action is conducted, a notification is sent to all neighbouring cells. If a conflict occurs (two cells receive their notification for action), it is resolved by applying a random backoff period for the action. This means that a frozen period (similar to busy channel in CSMA) occurs for all neighbouring cells. During the frozen period the neighbouring cells need to monitor the environment again before reaching a decision and possibly notifying and performing an action. This period is required in order to make sure that the small cells have taken into account the change in

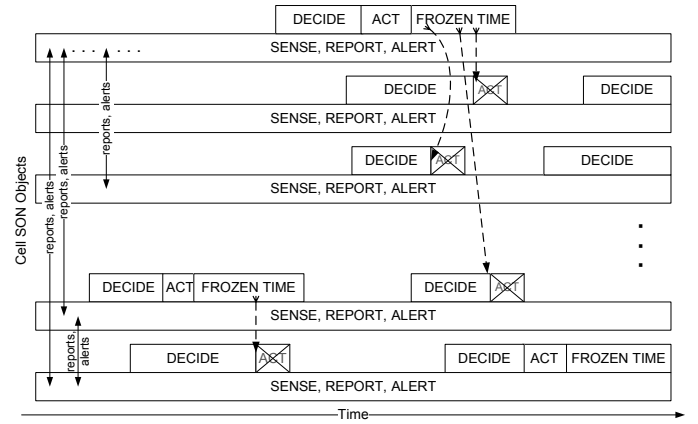

Fig. 3. Communication time frame

the environment as a result of the performed action. The frozen period can be predetermined or agreed among neighbouring cells. The duration of the period is dynamic and depends on the implemented optimization algorithm as well as the current state of the cell and neighbouring cells.

The proposed way of resolving the right to perform an action requires communication among all neighbouring small cells. For that purpose, X2 connections among the small cells can be used. Where X2 interface is not available, a femtocell gateway [5] can act as a proxy for the reports and actions requests. The actual communication among the cells is a challenging task and requires future considerations taking into account such aspects as synchronization and signaling load reduction.

V. CONCLUSION AND FUTURE WORK

We propose a SON based scheme for energy control in wireless heterogeneous networks. It allows for gradual transmission power change by individual nodes independently from the others, as it adopts a coordination approach from CSMA. The ongoing and future work includes designing of an efficient algorithm that can be deployed in the decision phase. Evaluation will test convergence and stability of the proposed control mechanism. Mechanisms of waking the nodes up and making them operational after the time of limited activity also require further study.

REFERENCES

- [1] O. Blume, H. Eckhardt, S. Klein, E. Kuehn and W. M. Wajda; "Energy savings in mobile networks based on adaptation to traffic statistics," Bell Labs Tech. J., vol. 15, no. 2, pp. 7794, Sep. 2010.
- [2] J. Hoydis, M. Kobayashi and M. Debbah; "Green Small-Cell Networks," Vehicular Technology Magazine, IEEE, vol.6, no.1, pp.37-43, Mar. 2011.
- [3] L. Kleinrock and F. Tobagi; "Packet Switching in Radio Channels: Part I-Carrier Sense Multiple-Access Modes and Their Throughput-Delay Characteristics," Communications, IEEE Transactions on , vol.23, no.12, pp. 1400- 1416, Dec. 1975.
- [4] 3GPP, TS 32.500, "Telecommunication management; Self-Organizing Networks (SON); Concepts and requirements", Feb. 2009.
- [5] S. Hamalainen, H. Sanneck and C. Sartori (Eds.); "LTE Self-Organizing Networks (SON)", John & Wiley Sons, Ltd., 2012.