



Hybrid Optical Fibre-wireless Links at the 75-110 GHz Band Supporting 100 Gbps Transmission Capacities

Zibar, Darko; Caballero Jambrina, Antonio; Yu, Xianbin; Pang, Xiaodan; Dogadaev, Anton Konstantinovich; Tafur Monroy, Idelfonso

Published in:

2011 Asia-Pacific, MWP/APMP Microwave Photonics, 2011 International Topical Meeting on & Microwave Photonics Conference

Link to article, DOI:

[10.1109/MWP.2011.6088767](https://doi.org/10.1109/MWP.2011.6088767)

Publication date:

2011

[Link back to DTU Orbit](#)

Citation (APA):

Zibar, D., Caballero Jambrina, A., Yu, X., Pang, X., Dogadaev, A. K., & Tafur Monroy, I. (2011). Hybrid Optical Fibre-wireless Links at the 75-110 GHz Band Supporting 100 Gbps Transmission Capacities. In *2011 Asia-Pacific, MWP/APMP Microwave Photonics, 2011 International Topical Meeting on & Microwave Photonics Conference* (pp. 445-449). IEEE. <https://doi.org/10.1109/MWP.2011.6088767>

General rights

Copyright and moral rights for the publications made accessible in the public portal are retained by the authors and/or other copyright owners and it is a condition of accessing publications that users recognise and abide by the legal requirements associated with these rights.

- Users may download and print one copy of any publication from the public portal for the purpose of private study or research.
- You may not further distribute the material or use it for any profit-making activity or commercial gain
- You may freely distribute the URL identifying the publication in the public portal

If you believe that this document breaches copyright please contact us providing details, and we will remove access to the work immediately and investigate your claim.

Hybrid Optical Fibre-Wireless Links at the 75-110 GHz Band Supporting 100 Gbps Transmission Capacities

Darko Zibar, Antonio Caballero, Xianbin Yu, Xiaodan Pang, and Anton K. Dogadaev, I. Tafur Monroy

DTU Fotonik, Department of Photonics Engineering, Technical University of Denmark, Kgs. Lyngby, DK-2800, Denmark
E-mail: idthm@fotonik.dtu.dk

Abstract— We present a photonic generation and down-conversion method for realizing a 40Gbps wireless link at the 75-110 GHz band exploiting the recent advances in photonic coherent detection technologies and digital signal processing. Furthermore, we analyze the capacities of hybrid optical fiber-wireless links at the 75-110GHz band, and propose several approaches to overcome the challenges towards 100Gbps wireless capacity.

Keywords— *microwave photonics, fiber-wireless communications, radio-over-fiber, digital signal processing, coherent detection.*

I. INTRODUCTION

Wireless links that can provide the same capacity as optical communication systems will provide a cost-effective solution for future's wireless/wireline seamless network integration [1]. In order to realize the seamless convergence of wireless and fiber-optic networks, the capacity of wireless transmission needs to be increased to keep the pace with high-speed fiber-optic communication systems. Achieving 100 Gbps data transmission is so far considered as an important milestone for future wireless communication links, in particular for short range applications. One of the drivers for 100 Gbps capacity from wireless links is the emergence of mobile devices such as tablets requiring more wireless connectivity to the network or cloud rather than local computing power, and the continued introduction of large bandwidth demanding rich media applications including future 3D Internet with end-users requesting wireless access.

Millimeter wave (mm-wave) technology is of great interest as one of the promising approaches to satisfy the high capacity requirement for the future wireless access networks. By definition, the mm-wave covers the frequency range from 30 GHz up to 300 GHz. However, the frequency bands less than 100 GHz have already been allocated for various applications, resulting in limited unlicensed bandwidth left for wireless transmission [1]. The applications and use of the 60 GHz band have been so far well studied and reported in many literatures, e.g. [2]-[4]. Nevertheless, the under-exploited higher frequency range from 100 GHz to 300 GHz

is becoming a timely relevant research topic due to its capability to offer an even wider bandwidth for even faster gigabit-class wireless access rate.

Recently, the 75-110 GHz band has received increased attention, because it can potentially provide the requested very high capacity. World wide spectrum regulations have allocated unprecedented large bandwidth for communications in this band [5]. Moreover, advances in high radio frequency devices, high speed optoelectronic components and photonic technologies are making it possible to realize multi-gigabit hybrid optical fibre wireless links [6-7]. Despite the impressive progress in multi-gigabit wireless links, achieving 100 Gbps data transmission at the 75-110 GHz band is still a challenge in terms of providing required power budgets, link linearity and efficient trade off between use of power and spectrum and practical implementation of advanced modulation formats.

In this paper, we firstly present a scalable mm-wave wireless fiber system operating at the 75-110 GHz band. The RF transparent signal demodulation, based on digital coherent detection is used at the receiver side. Free-running lasers operation for heterodyne generation and detection without the need of any optical phase locked loops is achieved. Using this approach, we successfully generate and demodulate up to 40 Gbps wireless signals in the 75-110 GHz band (W-band). Secondly, we analyze the capacity upper bound of this W-band channel and the challenges to achieve 100 Gbps wireless transmission capacity, and correspondingly propose several approaches towards 100Gbps wireless capacities. We believe this analysis will stimulate research and development towards overcoming the challenges to achieve 100 Gbps wireless links and their applications in future short range hybrid optical-wireless networks.

II. 40GBPS AT 100GHZ OPTICAL TRANSMISSION

A. All-optical OFDM transmission setup

The experimental set-up for the generation and detection of 40Gbps wireless OFDM signals is shown in Fig. 1. In the experiment, for generating three subcarriers all-optical OFDM

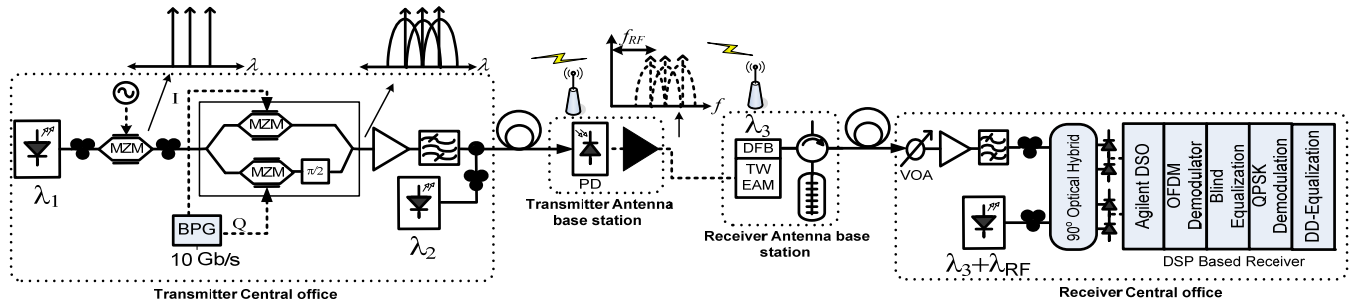

Figure 1: Experimental setup for the generation and demodulation of OFDM wireless signals. (The antennas are only for illustrative purpose and no wireless transmission was performed.) BPG: bit pattern generator, VOA: variable optical attenuator.

signal, the electrical clock signal frequency is changed to the baud rate and the MZM bias is chosen by optimizing the power of the three subcarriers (the optical carrier (λ_1), and the sidebands). The optical subcarriers are then fed into an optical I/Q modulator, where two independent data streams (pseudo random bit sequence of length $2^{15}-1$) at baud rate modulate the phase of the subcarriers resulting in QPSK modulation on the subcarriers. The output of the optical I/Q modulator is an all-optical OFDM-QPSK modulated signal. The all-optical OFDM-QPSK modulated signal is then amplified and combined with another un-modulated CW optical carrier (λ_2). The combined all-optical OFDM-QPSK signals and the un-modulated CW carrier are then transmitted to the remote antenna site (see Fig. 1) where they are heterodyne mixed in a (100 GHz bandwidth) Photo-Diode (PD). The output of the photo-diode is a high-capacity OFDM-QPSK electrical signal at the desired RF carrier frequency. The desired RF carrier frequency is simply chosen by varying the wavelength of the un-modulated CW optical source.

The electrical mm-wave OFDM-QPSK modulated signal is received at the receiver antenna site (Fig. 1) and transmitted through a few meter of fibre (~ 20 m) prior to signal demodulation using the RF transparent technique [8]. Prior to demodulation, the mm-wave signal is electrically amplified and modulated on an optical carrier at λ_3 , emitted from a distributed feed-back laser integrated with a 100 GHz travelling wave electro-absorption modulator (DFB-TW-EAM). Fig. 2 shows the output of the TW-EAM when modulated using a 10 Gbaud two subcarrier OFDM-QPSK wireless signal in the 75-110 GHz band ($f_{RF}=82$ GHz). From Fig. 2, it can be seen that the sidebands 82 GHz apart from the optical carrier (λ_3) contain the two subcarrier OFDM-QPSK signal. To perform the demodulation, only one of the sidebands is required, which is filtered out using a fibre Bragg's grating (FBG extinction ratio > 25 dB).

The pre-amplified optical signals after a filter are intradyne mixed with an optical local oscillator (LO) in an optical 90° hybrid. The photo-detected in-phase and quadrature outputs are sampled using a 20 GS/s real-time oscilloscope and demodulated offline. The demodulation process consists of OFDM demodulation, blind equalization,

QPSK demodulation and Decision-Directed (DD) post-equalization.

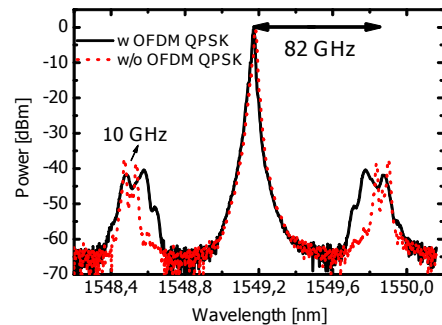

Figure 2: The optical spectrum at the output of the TW-EAM with and without the OFDM QPSK data modulation.

B. Experimental results

In Fig. 3(a), the bit error rates, versus the received optical power, of the single carrier QPSK and two subcarriers OFDM-QPSK wireless signal are plotted. It is observed that for the single carrier and multi-carrier OFDM modulation format, the BER below 10^{-3} , is achieved indicating successful signal demodulation. Additionally, the results indicate that it is possible to use all-optical OFDM for high-capacity wireless signal generation.

At the 75-110 GHz band, we have more available bandwidth and the baud rate is therefore increased from 5 Gbaud to 10 Gbaud, resulting in the total bit rate of 20 Gbps. A power penalty of around 4 dB is observed in the case of single carrier QPSK modulation at 10 Gbaud at a BER of 10^{-3} . This power penalty is as expected, since the amplifier used in the 75-110 GHz band has around 6 dB lower gain compared to the one used at 60 GHz. Similarly the 100 GHz photo-diode used for both 60 GHz and 75-110 GHz band has a 3 dB cut off bandwidth around 90 GHz. Also, the TW-EAM has a cut-off bandwidth of 75 GHz, and the product of the frequency response of all these components severely distorts the 75-110 GHz signals. We also tested the wireless signal generation and demodulation using two subcarriers all-optical OFDM at 5 Gbaud in 75-110 GHz band. The BER for the received power of -46.5 dBm, is shown in Fig. 3(a), and a relatively large

penalty is observed compared to the single carrier 10 Gbaud case. Even though the two subcarriers OFDM-QPSK signal at 5 Gbaud occupies less bandwidth compared to the single carrier at 10 Gbaud, the bandwidth limitation of the components and nonlinear phase response is more crucial for OFDM signal. Bandwidth limitation and phase ripple will destroy the orthogonality among the subcarriers and introduce inter-symbol interference (ISI) which is difficult to get rid of.

For the generation of 40 Gbps wireless signals the baud rate was set to 10 Gbaud which results in 20 Gbps data rate with single carrier QPSK modulation. Two sub-carriers are generated in an OFDM configuration resulting in a 40 Gbps optical two sub-carrier OFDM-QPSK signal. In Fig. 3(b), we summarized the highest achieved bit-rates when all-optical OFDM is used for wireless signal generation in 60 GHz and 75-110 GHz bands. At 60 GHz, we push the system performance by employing three subcarriers all-optical OFDM-QPSK for wireless signal generation at a total bit rate of 24 Gbps. It is observed in Fig. 3(b), that the average BER of the three subcarriers is below the UFEC limit. In the 75-110 GHz band, the baud rates of 8 Gbaud (two subcarriers all-optical OFDM is at total bit rate of 32 Gbps) and 10 Gbaud (resulting in the total bit rate of 40 Gbps) are tested.

The constellation diagrams of both the subcarriers of a 2-subcarrier OFDM-QPSK signal in the 75-110 GHz band are plotted in Fig. 4. Fig.4, indicates that in spite of the severe bandwidth limitations, constellation diagrams can be recovered. The BER of the subcarrier 1 and subcarrier 2 is -1.8 and -2.7 (below UFEC), respectively. It can be seen that the subcarrier 1 has a distorted constellation compared to the other subcarrier. This can be explained from the bandwidth limitations of the RF components involved. The total electrical bandwidth of the 40 Gbps QPSK signal is around 25 GHz (70-95 GHz), which is more than the bandwidth of the RF components, which severely distort the OFDM signal.

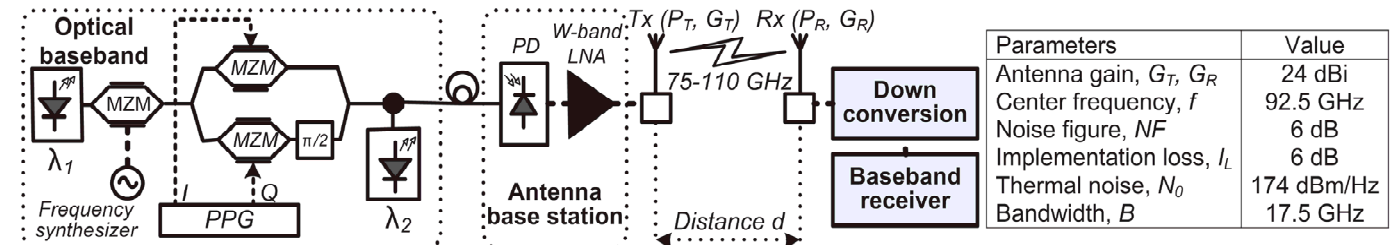
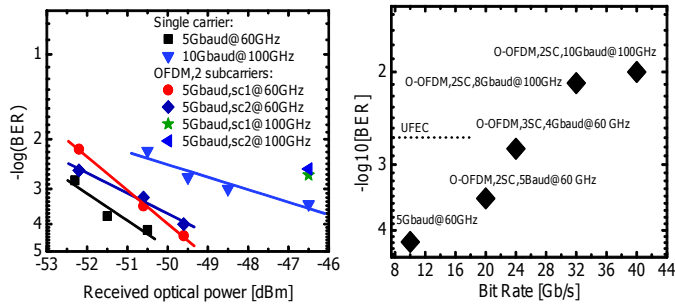

Figure 5. Schematic diagram of considered 75-110 GHz transmission link and default parameters for capacity analysis.

Figure 3: (a) The BER curves for single carrier and multi-carrier OFDM in 60 GHz and 75-110 GHz band. (b) The BER as a function of generated bit-rate.

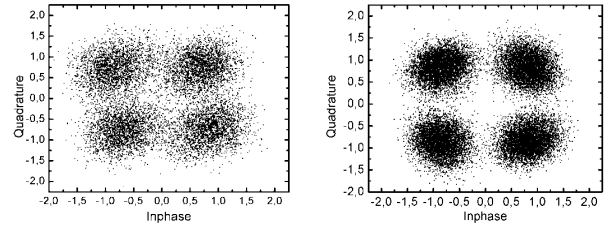

Figure 4: Constellation diagrams of the 40 Gbps 2 subcarrier OFDM-QPSK wireless signals. (a) Subcarrier 1, (b) Subcarrier 2.

III. CHALLENGES TOWARDS 100GBPS WIRELESS CAPACITY

Eventhough we have successfully demonstrated a 40Gbps W-band optical transmission system, no wireless link performance was analyzed yet above. Regarding the basic characteristics of the 75-110GHz wireless link, in terms of frequency response, phase noise, emission distance, directivity, etc, please refer to our another paper on wireless channel measurements [9]. In this part, we will theoretically analyze the capacity of the W-band wireless channel and point out the challenges towards 100Gbps wireless capacity [10]. The system with a W-band wireless link used for this analysis as shown in Figure 5, which is basically same as that in Figure 1.

A. Link power budget

Considering the line-of-sight (LOS) case in the wireless link, the signal-to-noise (SNR) ratio at the receiver side can be computed in dB using the link power budget equation [11]:

$$SNR = P_T + G_T + G_R - PL - I_L - (N_0 + 10 \log_{10} B + NF) \quad (1)$$

where P_T is the incident power into the transmitter antenna, G_T and G_R are the gains of transmitter and receiver antennas, respectively. N_0 represents the thermal noise in the system with a bandwidth of B , noise figure NF . I_L is the implementation loss of the link. PL is determined according to Log-distance path loss model for free space case as follows:

$$PL = 20 \log_{10} \frac{4\pi f d_0}{c} + 10n \log_{10} \frac{d}{d_0} \quad (2)$$

where d_0 is reference point situated in far field, c is the light speed, n is the path loss exponent (2 in a free space).

B. Capacity analysis and challenges to achieve 100Gbps solutions

Using the Shannon capacity limit as an upper bound, one can calculate combined gain of receiver and transmitter antennas to achieve a given capacity as a function of the transmission distance. The simulation results (Fig. 6), using parameters of inset table in Figure 5, show that 100 Gbps data transmission can be achieved at distances up to 7 m provided the value of the combined antenna gain equal to or larger than 48 dBi. We consider such a value being practically achievable with nowadays existing 75-110 GHz antenna technology.

Furthermore, we investigate the channel capacity for M-ary modulation formats. Figure 6b illustrates deterministic analysis of M-QAM modulation depending on the transmission distance. We can observe that 100 Gbps can be achieved by using a 64-QAM at distances less than 5 m. However, due to the higher gain and narrower radiation pattern requirements on the antennas, we could consider the use of array of antennas or multiple parallel channels. In this case, for example, one could employ 16-or 8-QAM to reach 100 Gbps using 2 parallel channels while reducing the symbol rate and SNR requirements. However, challenges associated with those implementations are related to low complexity technologies, ease of overall control and system optimization that requires further research and analysis. Besides that, in the fiber-wireless communications, the combination of multi-antenna and optical multiplexing technologies will further relax the system requirements to achieve 100Gbps capacity. In the meantime, techniques related to beam forming can also play an important role too for application in non-LOS environments.

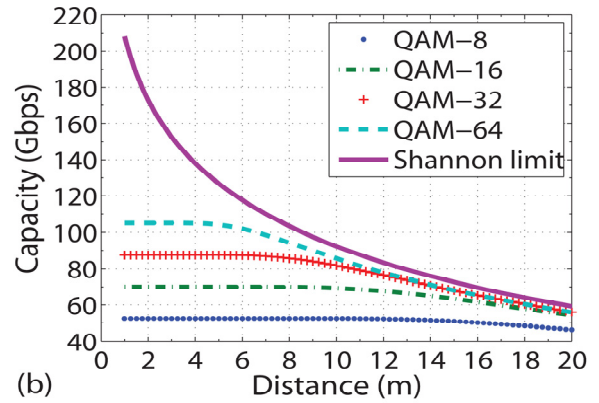
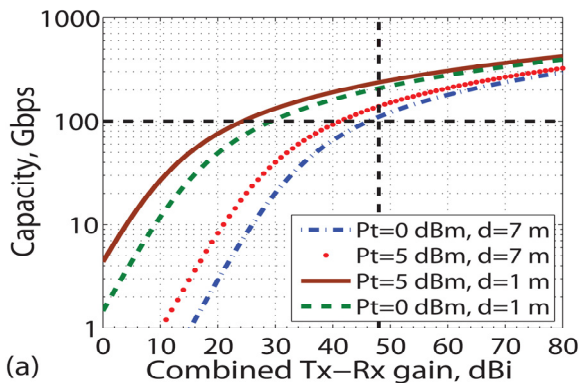

Figure 6. Simulation results for combined antenna gain at different distances (a) and capacity for M-ary modulation formats in 75-110 GHz band (b)

IV. CONCLUSIONS

We have presented a scalable high-capacity wireless signal generation technique based on a conversion of an all-optical OFDM baseband signal, to the wireless signal, by simple heterodyning and digital coherent detection at the receiver. It should be mentioned that this is the first experimental attempt to generate wireless signal capacities of up to 40 Gbps. The proposed technique for generation and demodulation is tolerant to dispersion and incorporates only baseband components which enable easy integration with current optical access networks. The data demodulation and advanced signal equalization are performed in software resulting in significant complexity reduction and increased flexibility. Moreover, we reported on the capacity analysis of 75-110 GHz wireless communication links for LOS case, using M-ary modulation formats. Analysis shows that 100 Gbps can be achieved provided that challenges on high antenna gain, potentially spatial diversity and beam steering are achieved, or several multiplexing technologies are employed, in particular for applications in short range networking scenarios.

REFERENCES

- [1] J. Wells, "Faster than fiber: the future of multi-Gbps wireless," IEEE Microwave Magazine, vol. 10, no.3, pp. 104-112, 2009
- [2] M. Beltrán, J. B. Jensen, X. Yu, R. Llorente, I. T. Monroy, "60 GHz DCM and BPSK Ultra-Wideband Radio-over-Fiber with 5 m Wireless Transmission at 1.44 Gbps", ECOC 2010, Paper Th.9.B.3.
- [3] H.S. Chung, S.H. Chang, J.D. Park, M.J. Chu, K. Kim "Transmission of Multiple HD-TV Signals over a Wired/Wireless Line Millimeter-Wave Link with 60 GHz", J. Lightw. Technol. vol. 25, no. 11, pp. 3413-3418, 2007.
- [4] C. T. Lin, J. Chen, P.T. Shih, W.J. Jiang, S. Chi, "Ultra-High Data-Rate 60 GHz Radio-Over-Fiber Systems Employing Optical Frequency Multiplication and OFDM Formats", J. Lightw. Technol. vol. 28, no. 16, pp. 2296-2306, 2010.
- [5] FCC Online Table of Frequency Allocations, Federal Communications Commission Office of Engineering and Technology Policy and Rules Division, July 2010.
- [6] A. Hirata, H. Takahashi, R. Yamaguchi, T. Kosugi, K. Murata, T. Nagatsuma, N. Kukutsu, and Y. Kado, Transmission Characteristics of 120-GHz-Band Wireless Link Using Radio-on-Fiber Technologies, J. Lightwave Technol. Vol. 26, pp. 2338-2344, 2008.

- [7] R.W. Ridgway, D.W. Nippa, and S. Yen, Data Transmission Using Differential Phase-Shift Keying on a 92 GHz Carrier, *Microwave Theory and Techniques*, IEEE Transactions on , vol. 58, no.11, pp.3117-3126, Nov. 2010
- [8] D. Zibar, R. Sambaraju, R. Alemany, A. Caballero, J. Herrera, and I.T. Monroy, "Radio-Frequency Transparent Demodulation for Broadband Hybrid Wireless-Optical Links," *IEEE Photonics Technology Letters*, vol. 22, 2010, pp. 784-786.
- [9] X. Pang, X. Yu, Y. Zhao, L. Deng, D. Zibar and I. T. Monroy, Channel Measurements for a Optical Fiber-Wireless Transmission System in the 75-110 GHz Band, MWP2011, Paper 2151.
- [10] A. K. Dogadaev, I. T. Monroy, Challenges and Capacity Analysis of 100 Gbps Optical Fibre Wireless Links in 75-110 GHz Band, accepted for publication in IEEE 2011 Photonics Conference.
- [11] J.G. Proakis, *Digital Communications*, ch. 5 and 7, McGraw-Hill, 4th ed., 2001.