



Wind turbine power performance verification in complex terrain and wind farms

Friis Pedersen, Troels; Gjerding, S.; Enevoldsen, P.; Hansen, J.K.; Jørgensen, H.K.

Publication date:
2002

Document Version
Publisher's PDF, also known as Version of record

[Link back to DTU Orbit](#)

Citation (APA):
Friis Pedersen, T., Gjerding, S., Enevoldsen, P., Hansen, J. K., & Jørgensen, H. K. (2002). *Wind turbine power performance verification in complex terrain and wind farms*. Denmark. Forskningscenter Risoe. Risoe-R No. 1330(EN)

General rights

Copyright and moral rights for the publications made accessible in the public portal are retained by the authors and/or other copyright owners and it is a condition of accessing publications that users recognise and abide by the legal requirements associated with these rights.

- Users may download and print one copy of any publication from the public portal for the purpose of private study or research.
- You may not further distribute the material or use it for any profit-making activity or commercial gain
- You may freely distribute the URL identifying the publication in the public portal

If you believe that this document breaches copyright please contact us providing details, and we will remove access to the work immediately and investigate your claim.

Wind Turbine Power Performance Verification in Complex Terrain and Wind Farms

Troels Friis Pedersen
Søren Gjerding
Peter Ingham
Peder Enevoldsen
Jesper Kjær Hansen
Henrik Kanstrup Jørgensen

RISØ
Tripod
Intercon
Bonus
NEG-Micon
Vestas

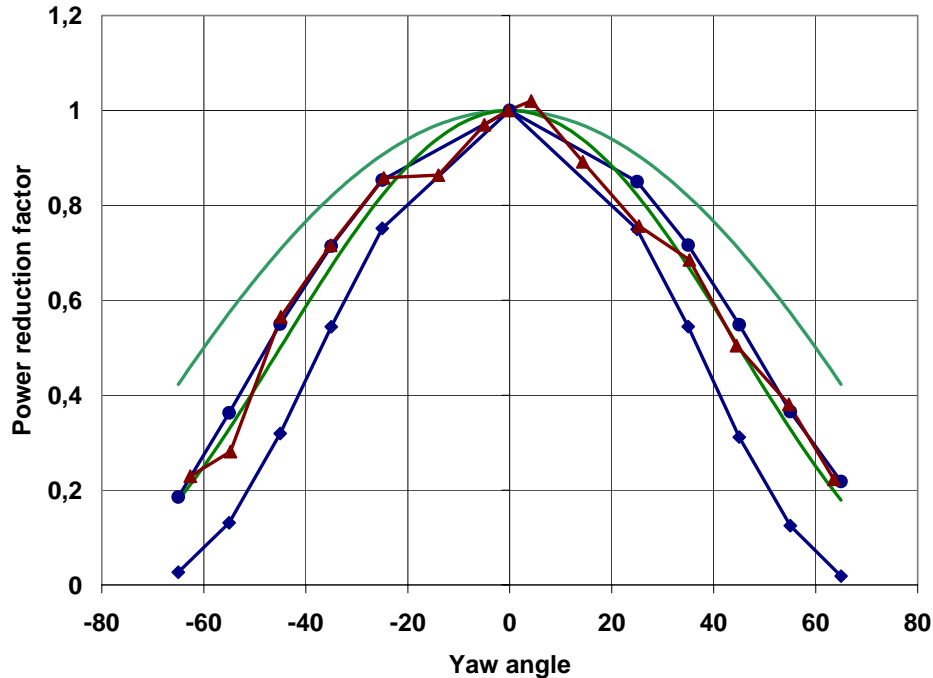

Abstract

The IEC/EN 61400-12 Ed 1 standard for wind turbine power performance testing is being revised. The standard will be divided into four documents. The first one of these is more or less a revision of the existing document on power performance measurements on individual wind turbines. The second one is a power performance verification procedure for individual wind turbines. The third is a power performance measurement procedure of whole wind farms, and the fourth is a power performance measurement procedure for non-grid (small) wind turbines. This report presents work that was made to support the basis for this standardisation work. The work addressed experience from several national and international research projects and contractual and field experience gained within the wind energy community on this matter. The work was wide ranging and addressed 'grey' areas of knowledge regarding existing methodologies, which has then been investigated in more detail.

The work has given rise to a range of conclusions and recommendations regarding: guaranties on power curves in complex terrain; investors and bankers experience with verification of power curves; power performance in relation to regional correction curves for Denmark; anemometry and the influence of inclined flow.

The current work was supported by the Danish Energy Agency under the UVE development programme, contract no. 1363/98-0017.

ISBN 87-550-3028-9
ISBN 87-550-3029-7 (Internet)
ISSN 0106-2840

Print: Pitney Bowes Management Services Danmark A/S, 2002

Contents

1. Introduction	7
2. Contractual issues regarding power performance verification in complex terrain - from manufacturers point of view	8
2.1 Background	8
2.2 Problems	8
2.3 Input by the Manufacturers	9
2.4 Methods	10
2.4.1 Method A	10
2.4.1.1 Site calibration	10
2.4.1.2 Measurement at the 'reference' site	10
2.4.1.3 Anemometers and Calibration	11
2.4.2 Method B	11
2.4.2.1 Uncertainties	11
2.4.2.2 Anemometers and Calibration	11
2.4.3 Method C	11
2.5 Conclusion	11
3. Requirements and Attitudes to Performance Verification - Developers/Investors/Banks -Today and in the future	12
3.1 Introduction	12
3.2 Response to questionnaire	13
3.3 Concluding Remarks	16
4. Some overall experiences from field measurements of power curves and energy production	17
4.1 Introduction	17
4.2 Experiences from production assessments - The Questionable On-site Power Curve Measurement	17
4.2.1 Background and Methodology	18
4.2.2 Results	18
4.2.3 Partial Uncertainties	22
4.2.4 Conclusion	23
4.3 Experiences from evaluation of power curves by Helge Petersen	23
5. Anemometry	24
5.1 Introduction	24
5.2 Cup-anemometer measurement differences under field conditions	24
5.3 Cup anemometer angular response characteristics	28
5.4 Overspeeding	29
5.5 Classification of cup anemometers	30
5.6 Definition of measured wind speed	32
5.6.1 Vector scalar wind speed	33
5.6.2 Horizontal wind speed	33
5.6.3 Longitudinal wind speed	34
5.6.4 Energy equivalent wind speed	34
5.7 Types of wind speed sensors	35
5.7.1 Vector scalar wind speed cup anemometer	35
5.7.2 Horizontal wind speed cup anemometer	35

5.7.3	Longitudinal wind speed cup anemometer	35
5.7.4	Energy equivalent wind speed sensor	36
5.7.5	Differences between the different definitions of wind speed	36
5.8	Conclusions and recommendations	39
5.9	Danish requirements to cup anemometry in power performance measurements	39
6.	Influence of flow inclination and turbulence on power performance measurements	41
6.1	Introduction	41
6.2	Influence of skew airflow	41
6.2.1	Wind turbine response to skew air flow	41
6.2.2	Power curve measurements in flat horizontal terrain	43
6.2.3	Power curve measurements in sloped terrain	44
6.2.4	AEP differences of power curves measured in flat and sloped terrain	44
6.2.5	Site calibration in smooth sloped terrain	46
6.2.6	Site calibration and power curve measurements in complex terrain	46
6.3	Influence of turbulence	47
6.3.1	Influence of turbulence and inclined flow on the cup anemometer	47
6.3.2	Influence of turbulence on the wind turbine	51
6.4	Conclusions regarding flow inclination and turbulence	53
7.	Conclusions and recommendations	55
8.	References	58

Preface

This report describes the work made within the UVE sponsored project “Verification of Wind Turbine Power Production Capability in Wind Farms and Complex Terrain” to support background research for revision of the existing standard IEC 61400-12. The project was made in cooperation between research, testing and advisory institutions and three large Danish wind turbine manufacturers. An important part of the work was a closed forum at project meetings, where discussions between all partners were very fruitful to the process. These discussions were the basis for finding “grey” areas in the measurement procedures, and for the synthesis of a common understanding of problems. A status of the project was presented at the conference “Vindkraft & Elsystem” 26-27 March 2001, Billund, sponsored by Energistyrelsen.

Many persons have taken part in the discussions and contributed to the work behind this report:

From RISØ:

Helge Aagaard Madsen
Søren Markkilde Petersen
Jørgen Højstrup
Flemming Rasmussen
Lars Landberg

Allan Vesth
Ioannis Antoniou
Uwe Schmidt Paulsen
Sten Frandsen
Troels Friis Pedersen

From Tripod:

Søren Gjerding

Jens Gjerding

From Intercon:

Peter Ingham

From NEG Micon A/S:

Jesper Kjær Hansen

Ole Fabian

From Bonus Energy

Peder Enevoldsen
Søren Oeman Lind

Henrik Stiesdal

From Vestas A/S

Bjarne Lausten
Michael Ariel Nielsen

Henrik Kanstrup Jørgensen

Troels Friis Pedersen, who was project leader, Peter Ingham and Søren Gjerding, has edited the report. As the report has been divided into contributions from different authors, some chapters are presented with author name. Troels Friis Pedersen edited chapters without author name.

1. Introduction

A revision of the IEC 61400-12 Ed 1 standard for wind turbine power performance testing, Ref. 1, is taking place in the coming years. The standard is being divided into four documents. The first is more or less a revision of the existing document on power performance measurements on individual wind turbines. The second is a power performance verification procedure for individual wind turbines. The third is a power performance measurement procedure of whole wind farms, and the fourth is a power performance measurement procedure for non-grid (small) wind turbines. This report presents work that was made to support this standardisation work. The project was developed to help provide a solid technical foundation for this revised standard, addressing experience from several national and international research projects and contractual and field experience gained within the wind turbine industry on this matter.

Power performance measurement procedures have been assessed through a number of EU projects, EWTS-I, Ref. 2, EWTS-II, Ref. 3, POWASS, Ref. 4, SMT project Task 1, Ref. 5 CLASSCUP, Ref. 6 and SITEPARIDEN, Ref. 7. All projects provide valuable knowledge that is being used in developing the revision of IEC 61400-12. The last three projects have been finished during the present project, and the results have been available for the revision. The last project was finished recently, and have shown some new results regarding site calibration during varying atmospheric stability conditions, which is important to take into account in future measurement procedure developments, but which has not been discussed in this project.

The contracts between wind turbine manufacturers and wind farm developers include directions for power performance measurements and warranty assessment procedures. The contracts refer to measurement procedures, which are far from being consistent enough to provide unambiguous results. It has therefore been a prime concern to investigate contractual matters regarding requirements for power performance verification. The practical experience in power performance measurements in the field by wind turbine manufacturers, consultants and testing institutes has therefore been of prime interest for the present assessment.

The project revealed some “grey” areas which have been of specific concern in this project. The first issue is regarding cup anemometry, including a relevant definition of measured wind speed. The various commercial cup anemometers perform very differently, specifically in complex terrain, therefore further analysis and conclusions have been made on this issue. The second issue is regarding power performance measurements under skew airflow. In complex terrain the wind turbine and the cup anemometer on the meteorology mast experience skew airflow, especially from inclination of the flow due to terrain slopes, but also from the tilting and from yaw errors. This impact on the power performance measurements is being assessed.

2. Contractual issues regarding power performance verification in complex terrain - from manufacturers point of view

Søren Gjerding, Tripod

2.1 Background

As part of the UVE Project *Improved demonstration of the production capacity of Wind Turbine Generators located in complex terrain* Tripod Wind Energy has been commissioned to investigate, how Wind Turbine manufacturers, which include Vestas Danish Wind Technology A/S, Bonus Energy, and NEG-Micon A/S, handle demonstration of Power Curves in connection with Contract Guarantees. This issue has been discussed with staff, responsible for such matters with each of the three manufacturers mentioned.

All manufacturers stress that there is a need for firm guidelines. They would welcome a unification of power curve guarantees, covering wind farms installed in complex terrain. All manufacturers realise, however, they are looking for a simple solution to a complicated matter.

2.2 Problems

When Wind Turbines (WTs) are installed in a complex terrain, there are a number of basic problems which are inherent in the Power Curve Guarantees. The two contract parties hold different views on these problems:

The Project Developer (Developer) requires a Power Curve Guarantee, covering the actual power curve for the WTs at the specific site.

The Manufacturer wishes to provide a Power Curve Guarantee, covering the Power Curve of the WT on an 'ideal' site, under standard conditions, i.e. a guarantee that is the inherent part of the official approval of the WT.

The Developer needs a guaranteed Power Curve that can be used in the feasibility calculations i.e. site specific; he has no interest in knowing how the WT would perform on an ideal site. The argument is relevant in a commercial sense, but may not be so in a technical sense. The argument of the Manufacturer is, that he has no way of knowing how the WT will perform under all possible conditions prevailing at the site where the WT may be erected. This is rather relevant from a technical point of view.

The technical problem is that the recognised methods used are assuming that the power output is a function of the wind speed, only needing to be corrected in regard to air density. In order to fulfil this assumption, restrictions are made to the site where the wind turbines are installed. When WTs are installed in complex terrain, other parameters influence the power output to a greater or lesser degree - some to a degree that cannot be neglected. Some important external parameters, which are also presented in Ref. 8 are shown in the list:

- Turbulence intensity
- Variability of wind direction
- Scale/spectral content of turbulence
- Vertical shear
- Horizontal shear
- Atmospheric stability
- Precipitation rate
- Yaw error

Considering that at present the commercial and the technical arguments are contradictory, pragmatic solutions have to be found.

As the power output of a WT is easily determined, the technical problems are related to the determination of the wind speed:

To determine the wind speed, 'experienced' by the WT.

To determine the uncertainty attached to the determination of the relevant wind speed.

Contractually, the main problems can be specified as:

How to measure the Power Curve.

How to use the uncertainties of the measurement in the calculations.

To determine the appropriate margin for the Power Curve measured in order to demonstrate the guaranteed Power Curve.

2.3 Input by the Manufacturers

The three manufacturers did not wish to provide or show specific material. Rather they were interested to discuss the concepts and the general attitudes towards different methods how to demonstrate the Guaranteed Power Curves, required by their customers in connection with contract negotiations.

Generally it should be mentioned that much time is being spent on the question of Power Curve Guarantees in connection with the wording of contracts. Special disagreement exists as to how the uncertainties shall be incorporated in a possible demonstration of the Guaranteed Power Curve.

Developers often find it difficult to appreciate that it is not always possible to carry out an unambiguous demonstration on the site. Basically the Developers are only interested in the output produced by the WT on *their* site. They are not interested in the output at an ideal, flat terrain.

As regards uncertainties, it is not unusual, even after a site calibration has been carried out, that the total uncertainty of a measured Power Curve - expressed by a standard deviation of the energy production - is 15 per cent or above. The question is then: Who shall benefit from this uncertainty - the Manufacturer or the Developer?

In some markets (Europe and USA), which are strongly influenced by Consultants and experienced Developers, the different Manufacturers often meet similar requirements. In markets, with less experienced Developers (Asia, Central and South America) it is usually the Manufacturer, who proposes the wording of the guarantee and the verification.

Attitudes differ whether guarantees shall deal with standard Power Curves (i.e. covering standard conditions) or whether it should be recalculated to actual site conditions. The attitude, among others, depends on the size of the project and/or the 'potential' of the customer.

In many cases the Manufacturer accepts the Developer's demands in spite of major uncertainties in the verification methods described, converting the technical risk by a possible verification measurement to an economic risk.

2.4 Methods

Guarantees and the verification for same may be divided into three main groups:

- Method A - Guarantees based on a standard Power Curve.
- Method B - Guarantees based on measurements by the nacelle anemometers.
- Method C - Guarantees based on Wind Farm Power performance.

In all three cases there are different attitudes towards the details of the methods, and towards how the uncertainties may be incorporated in the guarantees. Methods based on demonstration of stall level are also used to some extent outside Europe and USA.

2.4.1 Method A

Most Power Curve Guarantees, based on an international standard, are based on the IEC standard 61.400-12 *Wind Turbine Performance Testing*, first edition 1998-02, Ref. 1. In some other cases IEA, Ref. 9, or ECN, Ref. 10, standards are used.

In many cases the requirements are made more restrictive, as regards the site and the measuring sector (MEASNET procedure, Ref. 11), compared to the specifications in the IEC standard.

2.4.1.1 *Site calibration*

If the site does not meet the requirements of the IEC standard, a site calibration has to be carried out. None of the Manufacturers are prepared to make use of the flow calculation for the site calibration due to the uncertainties, and this method is being used in only few cases, therefore.

When measuring masts are being used for the site calibration, the guidelines of the IEC standard 61.400-12 are usually followed - or the guidelines may be even more restrictive. The requirements for the measuring period, number of data, data analyses etc. are handled individually.

It is normally agreed that the calculated uncertainties - as a result of a deviation from the 'standard site' - shall be included in the total uncertainty. General rules on (1) how to calculate the uncertainty and (2) how the uncertainty shall be transferred to the guarantee, have not been determined. However, it is clear that the issue is negotiable.

2.4.1.2 *Measurement at the 'reference' site*

If the Power Curve cannot be demonstrated for the site, the Manufacturer - in a number of cases - has inserted a clause in the contract, reserving the right to move one of the WTs to a flat terrain, which meets the standard, in order to carry out the Power Curve measurement there. Clearly, this is a very expensive solution, which, primarily, should be seen as an "emergency clause" in projects, where the compensation for non-compliance with the guarantee is quite substantial. There is no information available whether any Manufacturer has in fact made use of this reservation.

In most cases the measurement is only an option for the Manufacturer, where the "losing" part in the conflict has to pay the cost involved. Therefore, the res-

ervation clause has induced the parties to reach an amicable settlement - considering the size of the compensation involved.

2.4.1.3 *Anemometers and Calibration*

The requirements to the type of anemometers have not been clarified, neither how and where they should be calibrated. In some contracts it is a requirement that the anemometer shall be calibrated in an European wind tunnel and sometimes, the requirement goes even further, requiring the use of the same wind tunnel which was used when the guaranteed Power Curve was measured. In some cases the latter is an option, that the Manufacturer may choose to use, if the Power Curve verification is not in accordance with the guarantee.

2.4.2 Method B

Basically, all Manufacturers agree that the use of nacelle anemometers for Power Curve verification is subject to a considerable uncertainty. However, since this is an operational method, some Developers want to use this method. Most probably the method is used much more than desirable from a technical point of view.

Usually, the Manufacturer provides a measurement where the correlation between the V_{free} and V_{nacelle} is described. The division of data in relation to sectors, levels of turbulence etc. are not treated in a uniform manner.

2.4.2.1 *Uncertainties*

The requirements to the calculation of uncertainties and the wording of guarantees have not been clarified.

2.4.2.2 *Anemometers and Calibration*

The requirements to the type of anemometers have not been clarified, neither how and where they should be calibrated.

2.4.3 Method C

The method, which is described in *Working group activity IEC 61.400-122 under TC88 MT13/WG6*, is based on a measured reference wind distribution, by using a measuring mast 'in front of' the wind farm. The power output from the wind farm is then determined by applying the measured wind distribution in a flow model calculation, which takes the terrain conditions into consideration. The calculated power output is compared to the actual power output from the wind farm measured at grid connection via the SCADA system during the period, considered.

However, all Manufacturers agree, that it is not in their interest that this method becomes a norm to be included in the contracts. The operational idea of the proposal is acknowledged, but the Manufacturers are quite worried about the uncertainties and the subsequent risks for the manufacturers, if the norm will be adopted.

2.5 Conclusion

It must be concluded that the Manufacturers desire a unification of the Power Curve guarantees and the verification of the Power Curve for Wind Turbines erected in complex terrain. This will assure a more transparent competition, as the wording of the guarantee does not become a commercial parameter influencing the price.

3. Requirements and Attitudes to Performance Verification - Developers/Investors/Banks -Today and in the future

Peter Ingham, Intercon

3.1 Introduction

Based on experience from a number of wind energy turn-key contracts working as a consultant for investors, banks, developers and WTG manufacturers, a questionnaire was set up that covered all the typical contract discussion points concerning the performance verification of a number of WTGs with special emphasis on the problems related to larger projects in complex terrain. This questionnaire was then forwarded to 3 investors, 2 banks, 1 insurance company and 2 developers who all have experience from larger turn-key wind energy projects in Europe and for whom InterCon has been working as an independent consultant on the power performance issue. The complete questionnaire is shown below.

Abbreviations:

PC = Power Curve

PCV = Power Curve Verification

WTG = Wind Turbine Generator

1	Do you require a site specific design approval or a standard type approval (IEC class or similar)?
2	Do you require independent production certificates of conformity for all WTGs?
3	Do you require independent installation certificates of conformity for all WTGs?
4	Do you require an on-site PC measurement or do you accept the type approval PC?
5	If on- site PC measurements are required, how many WTGs should be measured?
6	Do you accept on-site PCV by nacelle anemometry alone?
7	Do you accept on-site PCV for a number of WTGs by PC measurement according to a standard like the IEC 61400-12 on one WTG combined with nacelle anemometry for the other WTGs?
8	Would you accept an on-site PC based on PC measurements on a single WTG under flat terrain test conditions transformed to on-site conditions through calculations?

9	Do you accept to include the actual measuring uncertainty in full to the benefit of the WTG supplier? If so, at what confidence level (68%, 90%, 95%)?
10	If an on-site PCV is in default (complex terrain), will you then accept the WTG if it passes a PCV in flat terrain?
11	Do you include the site specific climatic conditions and micro-siting as contractual design and performance parameters towards the WTG supplier?
12	The energy yield of a wind farm is a function of: the WTG std. PC + the wind distribution (from the wind study) + array losses (micro-siting) + site specific climate (air density, mean and seasonal variation). How do you ensure the accuracy of the last three items in a contract?
13	Do you have specific requirements in the OMS contract regarding check of allowable changes in the PC over time? If yes, how do you check it?

3.2 Response to questionnaire

The response was somewhat dissapointing but predictable: None of the selected group were interested in giving written answers or having their names mentioned in the report. However, based on follow-up calls and discussions in connection with other work it has been possible to point out some common attitudes in the target group on how to deal with the power performance verification issue.

The following answers to the questionnaire represent the attitude and requirements of the “average” buyer/owner/bank.

1. *Do you require a site specific design approval or a standard type approval (IEC class or similar)?*
The standard type approval is more or less the main requirement and it is typically up to the manufacturer to ensure that the requested design class is sufficient for the actual site.
2. *Do you require independent production certificates of conformity for all WTGs?*
The buyer will normally accept the manufacturer’s own QA system as sufficient. It is the general opinion that the conformity of the WTGs from the production line is high with only marginal variations in assembly and quality.
3. *Do you require independent installation certificates of conformity for all WTGs?*
Again, the buyer normally accepts the manufacturer’s own QA systems. However, the buyer will typically hire a technical consultant to monitor the installation work on behalf of the buyer.
4. *Do you require an on-site PC measurement or do you accept the type approval PC?*
Practically all projects require some kind of on-site power performance verification, but mainly as a formality (see item 6).

- 5 *If on-site PC measurements are required, how many WTGs should be measured?*
 Depending on the number of WTGs the general attitude is that at least two WTGs should be measured on-site. However, power curve measurements are very expensive for larger WTGs and in complex terrain that requires a site calibration carried out prior to the power curve measurements. Many contracts are made such that the buyer will have to pay for the verification measurements. Only if the WTG fails the test will the manufacturer have to pay for a second measurement.
- 6 *Do you accept on-site PCV by nacelle anemometry alone?*
 Nacelle anemometry is generally accepted for power curve measurements even though the manufacturers are aware of the problems with this method. As long as the majority of the power curves measured this way are within the guaranteed limits, the attitude of both the manufacturer and the buyer seems to be not to pursue the issue any further. The power curve measurement becomes a formality that hopefully will not require further attention.
- 7 *Do you accept on-site PCV for a number of WTGs by PC measurement according to a standard like the IEC 61400-12 on one WTG combined with nacelle anemometry for the other WTGs?*
 Most buyers and technical advisors would be happy by having one WTG measured in compliance with the IEC 61400-12 and the remaining controlled by the nacelle anemometry. This is probably also a relatively accurate way provided that the terrain complexity does not vary too much over the site.
- 8 *Would you accept an on-site PC based on PC measurements on a single WTG under flat terrain test conditions transformed to on-site conditions through calculations?*
 Although this method is probably the most accurate way of verifying the WTG performance (provided that the flat terrain tests include measurements with the WTG adjusted to on-site settings) this is not acceptable for most buyers, maybe simply because of the psychological value of actually seeing the tests being performed on-site. Despite this, some contracts allow the manufacturer to re-test a WTG in flat terrain at his own expense if it has failed an on-site power curve test.
- 9 *Do you accept to include the actual measuring uncertainty in full to the benefit of the WTG supplier? If so, at what confidence level (68%, 90%, 95%)?*
 Surprisingly, many manufacturers are happy to accept a flat 5% deduction to cover both a lack in performance and the measuring uncertainty. If the measuring uncertainty is to be included to the benefit of the manufacturer, this would always be at the standard uncertainty level, i.e. at a confidence level of 68%.
- 10 *If an on-site PCV is in default (complex terrain), will you then accept the WTG if it passes a PCV in flat terrain?*
 In some cases, the buyer will allow the manufacturer to re-test a WTG in flat terrain after it has failed an on-site power curve test. However, the costs involved are high and therefore other solutions are normally preferred, e.g. up-grading the blades, higher towers or supplying an extra WTG for free to reach the promised nominal energy production.

- 11 *Do you include the site specific climatic conditions and micro-siting as contractual design and performance parameters towards the WTG supplier?*

While the micro-siting is normally always included in the contract, only some of the climatic conditions are included, like mean, max and min temperature, air density, mean wind speed distribution, 10 min and 3s 50 year gust wind speeds and mean turbulence intensities at different wind speeds. However, the tendency is to include a much more details on the site specific climatic conditions in the wind study work and then to include the wind study or its results in the contract regarding the site specific conditions.

- 12 *The energy yield of a wind farm is a function of: the WTG std. PC + the wind distribution (from the wind study) + array losses (micro-siting) + site specific climate (air density, mean and seasonal variation). How do you ensure the accuracy of the last three items in a contract?*

The power curve is dealt with in any contract. It has to be guaranteed and normally also verified through on-site measurements. In case of a default situation, the manufacturer will have to pay for the missing production and so on. As it has been documented by InterCon there is strong statistical evidence, however, that the power curve for a given type of WTG is very constant with a typical variation of 2-3%, i.e. 2-4 times less the uncertainty of the power curve measurement itself.

With regard to the wind study and micro-siting it's totally different. There are no standards or recommendations on how to carry out the wind measurements and how to deal with uncertainties. The on-site variation in wind speeds is usually calculated with WASP or other similar flow models without having any standards for checking the results. The scaling of short term measurements to long term conditions is more or less up to the individual doing the work. In other words, there are no quality requirements, standards or procedures to refer to in a contract for the wind study work despite the fact that actual uncertainties in the derived energy production due to uncertainties in estimating the wind distribution are many times higher than any possible deviation in the power curve. All the same, the buyer/investor/bank still relies totally on having confidence in the wind energy consultant doing the wind study (and possibly a due diligence on the work by a third party).

There are no indications that this attitude will change in the near future.

- 13 *Do you have specific requirements in the OMS contract regarding check of allowable changes in the PC over time? If yes, how do you check it?*

Typically, the OMS contract will not have any specific requirements regarding the power curve over time. Even for those contracts having a continued guarantee on the power curve, it would normally not be possible to carry out the verification in praxis. However, there is often a requirement for "clean" blades which is typically detected by the WTG's own power curve monitoring system.

3.3 Concluding Remarks

The overall impression from the various contacts to the target group is that investors and banks are becoming increasingly professional and aware of the necessity for reliable wind studies, verification of power curves etc. Rather than try to cover all the technical aspects by themselves they use recognized independent technical consultants throughout the developing and implementation phase and rely on their expertise and advices. This is a positive trend that allows a faster implementation of new research results and recommendations.

There are, however, still facts of major importance for the viability and success of a wind energy project that are not yet really properly understood by neither the target group nor many consultants and researchers. These facts are:

- A: The on-site measured power curve for exactly the same WTG will depend on the topography of its actual position. This is because the energy flux will change even if the hub height wind speed is the same. Thus, the power curve becomes a characteristic of not only the WTG itself but of the topography too (here the influence of air density is assumed adjusted for). The on-site power curve measurement as a verification of the performance ability of the WTG is therefore not a technically valid method without some kind of adjustment for the terrain influence. At present there are no reliable methods available for such adjustments.
- B: The uncertainty of power curve measurements, even for flat terrain, is of the order of 6-8% while the statistical variation (the standard deviation) of the power curves for a given type of WTG is in the range of 2-3%. In other word, the uncertainty in making a power curve verification is several times higher than the variations looked for!
- C: While there is a 1:1 relation between the energy production and the power curve, the energy production changes with the mean wind speed raised to the 2nd to 3rd power. Therefore, the energy production is much more sensitive to errors and uncertainties in the wind study than to deviations in the power curve. Typical uncertainties of a (good) wind study are in the range of 8-12% on the derived energy production which makes the wind the number one parameter of importance for a project.

Despite this fact, there is at present no standard or guidelines on how to measure the wind conditions, how to transform short term measurements into long term wind conditions, how to check the flow models applied to establish a wind atlas for the site, how to deal with the involved uncertainties in measurements, modelling and transformations to hub heights etc. etc. While the turnkey contract will normally be very specific in the requirements to the power performance and the availability of the WTGs, there are no similar requirements to the quality of the wind study and micro-siting. Typically, there is not even a contractual requirement to install and carry out site-calibrated wind measurements after commissioning of the wind farm to allow long term verification of the wind conditions.

4. Some overall experiences from field measurements of power curves and energy production

4.1 Introduction

In general, power curve measurements are having high uncertainties, i.e. typically 5-10% in AEP in flat terrain. This uncertainty is an absolute value of the measurement itself. On a larger scale, where many power curve measurements are taken into account, some general details that are more precise than the individual measurement can be detected. Peter Ingham and Helge Petersen have made such analysis based on power curve measurements on many wind turbines and energy production by a large number of wind turbines. Their analysis indicate upper limits of uncertainties of integrated wind turbine power performance, and indicate the levels of uncertainty in measurements that are needed for detailed conclusions regarding individual power performance of wind turbines, being used for instance for optimal performance research purposes or warranty assessments.

4.2 Experiences from production assessments - The Questionable On-site Power Curve Measurement

Peter Ingham, InterCon

During 1993-1997 a research project financed by The Danish Energy Agency and headed by InterCon, Ref. 12, was carried out that lead to the establishment of a set of regional correction curves for Denmark to be used together with the WAsP wind atlas program from Risø. The work included detailed on-site assessment and production analyses for 169 Danish and 30 German WTGs.

An interesting and somewhat controversial spin-off result from this project was that the standard uncertainty for power curves for the same type of (Danish) WTGs statistically proved to be of the order of 2-3% which is 3-4 times less than the uncertainty of any known power curve measuring techniques used today, even for flat and simple terrain. The report therefore concluded:

The value of on-site power curve measurements¹ in complex terrain as a tool to verify the performance ability of a given WTG is very questionable.

¹ *Using known measuring techniques of today*

A short summary of the findings and arguments from the report leading to the above conclusion will be given in the following.

4.2.1 Background and Methodology

The background of the research work was a need to improve the standard wind atlas method and/or wind atlas for Denmark which had been in use for a decade at that time. Practically all production calculations in Denmark were (and are still) based solely on a terrain assessment and the use of a single wind atlas for the whole country, i.e. without on-site wind measurements. Even though it was well known that the geostrophic wind (and hence the wind atlas) was not constant over Denmark, the changes in wind distributions were too small to enable establishment of local wind atlases based on wind measurements alone.

The fundamental idea of the research project was therefore to use WTGs as measuring devices and their energy production as the measured parameter rather than measuring the wind speed. The WTG rotor acts like a wind speed integrator over time (a month, a year etc.) which is very sensitive to changes in the mean wind speed because of the general energy flux proportionality to the wind speed raised to the third power. Such a method could only work under the following assumptions and requirements:

1. A large number of preferably identical WTGs had to be present and evenly distributed over Denmark.
2. Reliable production figures had to be available for the WTGs for a number of years.
3. A reliable energy production index should exist to adjust the actual WTG production figures to a normal year.
4. New, controlled terrain assessments and wind atlas calculations had to be carried out for all the WTGs.
5. Since only the mean wind speed was considered, the wind direction distribution had to be practically constant for all sites.
6. THE POWER CURVES HAD TO BE IDENTICAL FOR ALL WTGS OF THE SAME TYPE

If all the above assumptions were met, it should be possible to establish ratios of observed productions (adjusted to a normal year) to the calculated productions for all WTGs. These ratios, known as “Goodness factors” should, if all assumptions were met, be a direct measure for the regional deviation from the constant wind atlas (and thus constant geostrophic wind) applied. This goodness factor could then be used for future wind atlas calculations as a regional correction factor to be applied directly to the calculated annual energy production.

4.2.2 Results

A first phase was carried out including 40 WTGs distributed over Denmark (not evenly). For each WTG its Goodness factor was established and a set of smooth correction curves was fitted to the observations. These correction factors ranged from 0.86 to 1.22 and is shown in the figure.

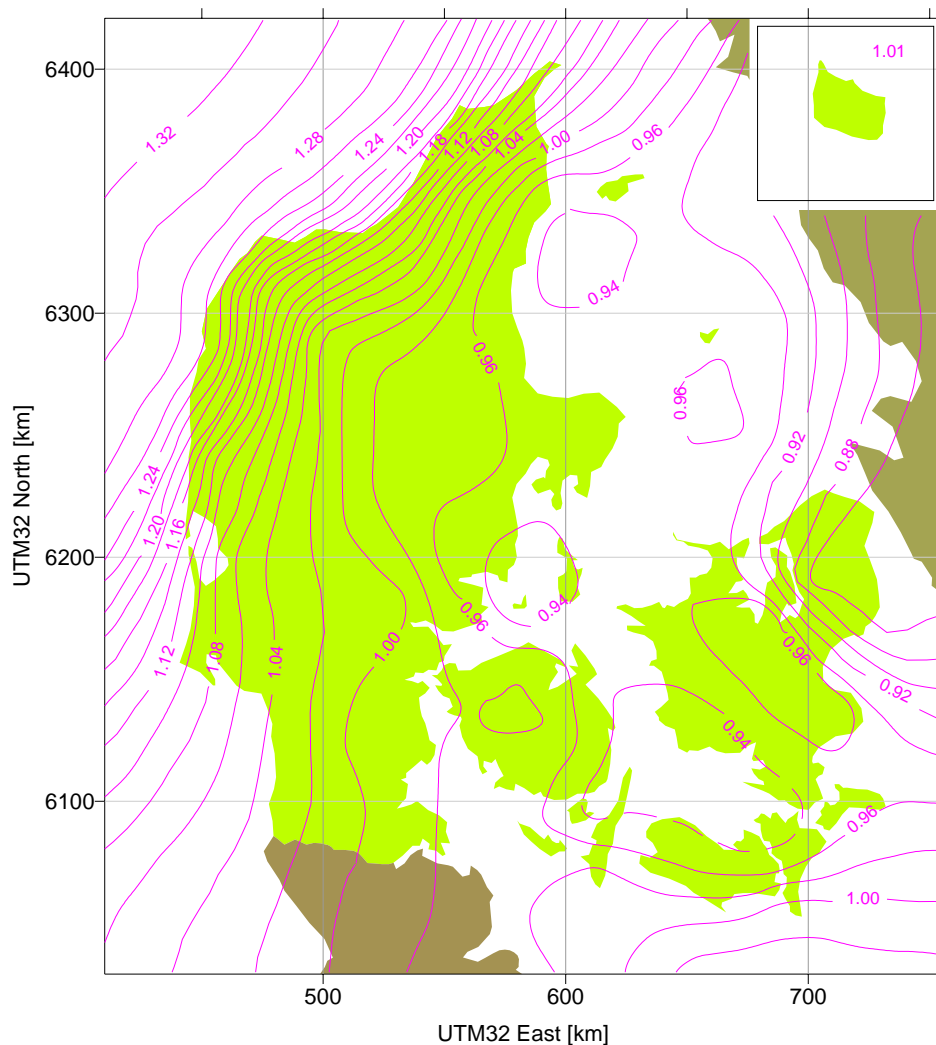

Figure 4-1 Correction factors for Denmark

Due to the various uncertainties involved, a perfect curve fit to the 40 observations of Phase 1 was not possible. After applying the correction factors from the fitted curves to the observed productions, the mean and std. dev. was calculated for the adjusted goodness factors. While the mean was of course identically equal to 1, the std. dev. was found to 7.9%.

In the second phase a total of 145 new control WTGs (129 in Denmark and 16 in Germany) were analysed and their goodness factors calculated after applying the regional corrections found from the correction curves from phase 1. Also, the 40 WTGs from phase 1 were re-calculated to include approx. 2 years of additional production data. The figure shows the location of all the control WTGs (crosses) and groups of WTGs (circles).

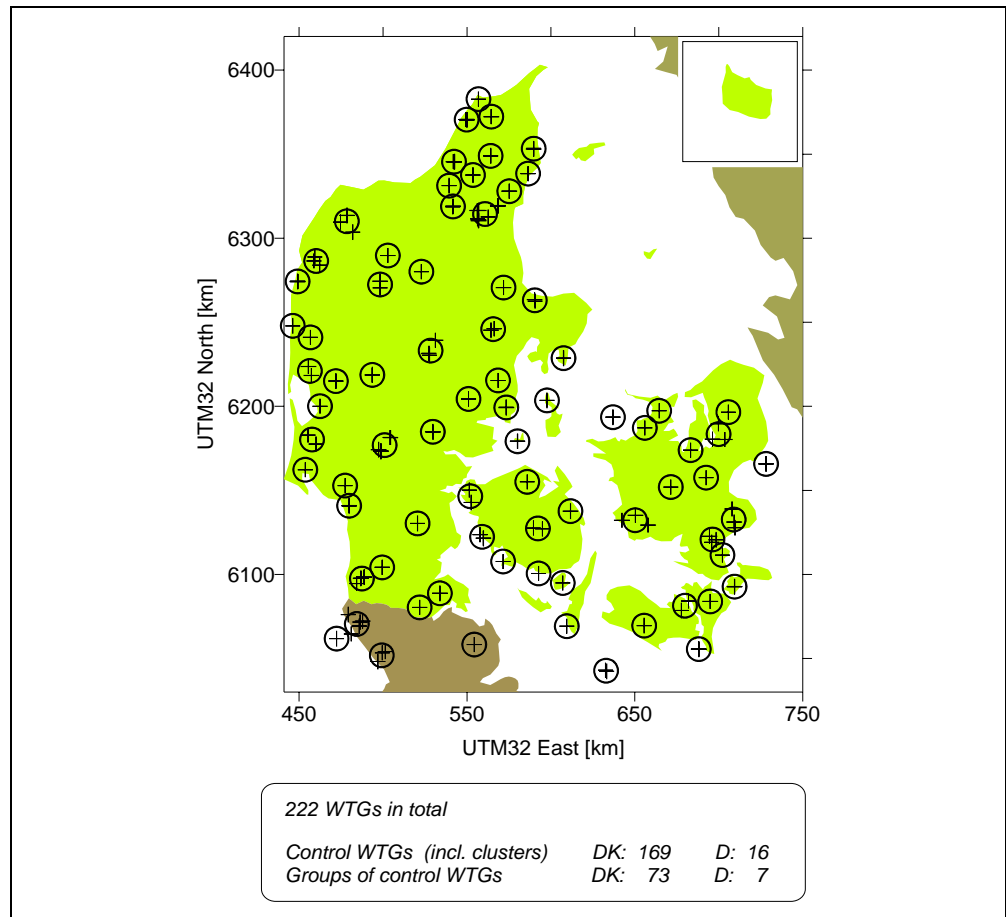

Figure 4-2 Position of control wind turbines

Since all the new WTGs had been selected based on the requirement that they should fill-up the “holes” between the original 40 WTGs and ensure as uniform a distribution over Denmark as possible, no bias was present between the results from phase 1 and the calculated goodness factors for the new WTGs. Thus the method and the found correction curves should be accepted as verified if the new mean of goodness factors was close to unity and the std. dev. within the same range as found in phase 1. A final acceptance criteria would be that the distribution of goodness factors was close to that of a normal distribution.

The results were in almost perfect agreement with the expectations and verified the method and the correction curves in full. As can be seen from the table below, the new goodness factor mean is now 0.99 and the std. dev. as low as 5.3%. Also, the distribution is close to that of a normal distribution.

Table 4-1 Goodness factors

Goodness Factors	Phase 1 updated	Phase 2 Final
<i>Danish WTGs</i>		
Mean	1.00	0.99
Std. Dev.	0.027	0.053
Minimum	0.95	0.80
Maximum	1.08	1.12
No of WTG control points	69	165
Uncert. on mean (95%)	0.006	0.008

NE index used for Normal year correction

Finally, the observed distribution of goodness factors was plotted together with the corresponding normal distribution. The result is given in the figure below which shows that the observations are, in fact, nearly normally distributed, thus indicating that the observed variation is true stochastic and thereby a true estimator for the total uncertainty of the method.

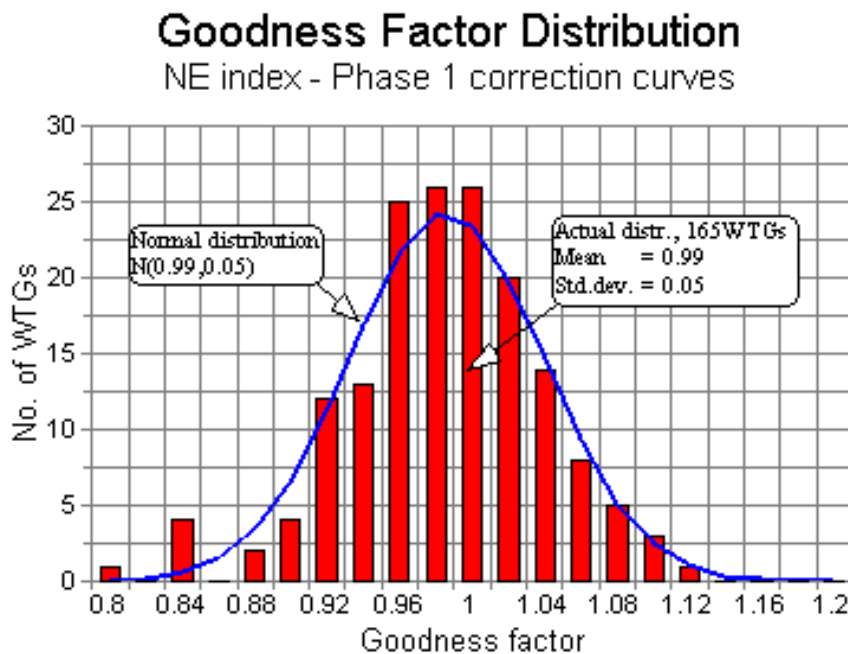

Figure 4-3 Goodness factor distribution

During the 5 years the project lasted, WTGs were taken out of various reasons and other WTGs added. In total 222 WTGs were used, either partly or in full, representing 11 different Danish manufacturers and WTG sizes from 75kW to 250kW. Furthermore, comparison of the different types of WTGs within the same location made it necessary to establish and apply type specific power curve corrections relative to the BONUS 150 /23 used for reference as shown in the figure.

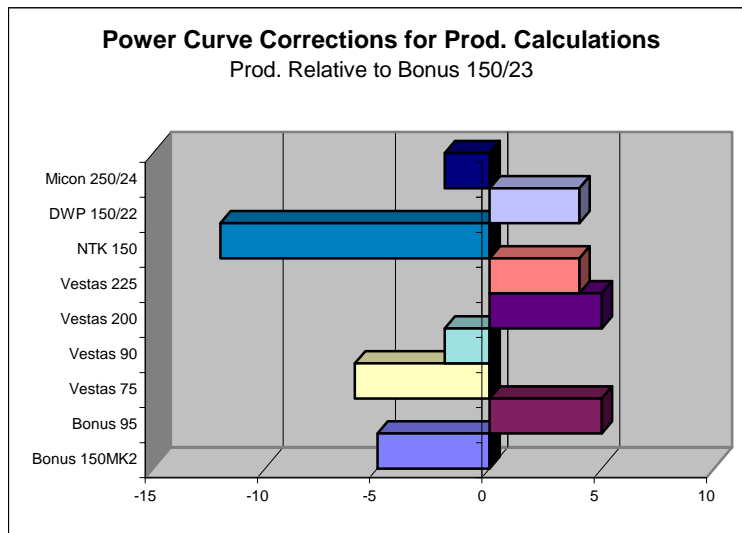

Figure 4-4 Corrections for production calculation

4.2.3 Partial Uncertainties

There are 5 independent uncertainties of importance for the joint uncertainty of a production estimate using the correction curves:

1. Uncertainty on the terrain assessment
2. Uncertainty on the actual production figures
3. Uncertainty on the model (orography, obstacles, curve fitting etc.)
4. Uncertainty on the applied power curve corrections
5. Uncertainty on the power curve within the same type of WTG

Taking the uncertainties as the standard uncertainties s_1 to s_5 we have:

$$s_{tot}^2 = \sum_{i=1}^5 s_i^2$$

Since $s_{tot}^2 = 5.3\%$, no single partial uncertainty can be more than 5.3%. The following uncertainties can be derived from the report:

- $s_1 = 1\%$
- $s_2 = 1\%$ (this is an estimate based on comparison of log books and actual payments)
- $s_3 = 3\%$
- $s_4 = 3\%$

From these uncertainties the uncertainty on the power curve within the same type of WTGs is found:

$$s_5 = \sqrt{(5.3^2 - (2 + 2 \cdot 3^2))\%} = \sqrt{8.1\%} = 2.8\%$$

4.2.4 Conclusion

It can therefore be concluded that the variation in power curve within the same type of WTG will, in general, be of the order 2-3 % and almost certainly not exceed 5% in any case. Since the uncertainty in power curve measurements for ideal test sites is of the order of 6-8% and for complex sites more, the value of on-site power curve measurements must be characterised as highly questionable.

When power curve measurements in complex terrain in some cases do show significant deviations in power curves for the same type WTGs, this can normally be traced back to significant terrain induced differences in the wind flow over the rotor. Since power curve measurements refer to the a single point wind speed at hub height, the *same* WTG will exhibit different power performance characteristics for different terrain induced wind flow. A need therefore exists for further measurements and analyses of how the power curve (based on hub height wind speed) changes as a function of terrain complexity, especially the wind shear profile. Only then will it be possible to assess and calculate the terrain dependent changes in the power curve and thereby in the energy production which is, after all, the bottom line figure of interest for the owners and investors.

4.3 Experiences from evaluation of power curves by Helge Petersen

Helge Petersen Consult has collected quite a number of power curve measurements made by various testing institutes. On basis of the power curves he made some investigations to deduct general characteristics of the wind turbines. He presented his first reports in Danish in 1995, Ref. 13 and 14. Ref. 14 is a collection of measured power curves, which are analysed and compared in order to derive concept deviations and technical-economical comparisons. This was updated in 1998, Ref. 15, and in 2001, Ref. 16. The reports are mainly comparing measured power curves, and the conclusions of the last report are: "The findings show that the differences in specific energy production between turbines of identical specific rotor loading are remarkably alike. Dividing the wind turbine types into two groups, one group with the stall regulated types and another with the pitch regulated and active stall regulated types, it is found that the specific energy production of the two groups differs by a few percent to the favour of the pitch or active stall regulated, but within each group the deviations are very small". He concludes in the third report, that the differences in specific rotor loading seem to be independent of make. He also reports differences of power curve measurements of same make and type by different institutes up to 2-4%.

The analysis and conclusions by Helge Petersen show that differences between makes, types and power regulation configurations are very small, and that other parameters, like rotor loading can be generalized, so that individual differences from the general behaviour are very small. This emphasises, that the uncertainty in power curve measurements must be kept very small (in the order of a few percent) to be able to determine individual differences.

5. Anemometry

5.1 Introduction

The past years of experience in power performance measurements have shown a very strong need for very accurate wind speed measurements. The work on cup anemometry have shown some new experience, which support new and stronger requirements to instruments. In the European SITEPARIDEN project, Ref. 7 commercial cup anemometers have been compared in field measurements at height above ground from 8m to 30m. These measurements have shown up to 4% difference of the cup anemometer readings. Similar differences were found by Papadopoulos et.al., Ref. 17. This is very significant in power performance measurements, and very unsatisfactory. Another European project, CLASSCUP, Ref. 6, analysed cup anemometers by wind tunnel investigations and laboratory tests. This project showed significant differences of the cup anemometers in angular and overspeeding characteristics. Two other important results of this project showed that some new design features are possible. In the project it was verified that angular characteristics of cup anemometers could be flat from -40° to $+40^\circ$. Some results from the two projects and an analysis on wind speed definition consequences was presented in two notes and distributed to the IEC-TC88-MT12 working group on Power Performance Measurements, Ref. 18 and 19. The following chapters are partly based on these notes.

5.2 Cup-anemometer measurement differences under field conditions

The substantial differences, measured between different cup-anemometers in the SITEPARIDEN project, are described in Ref. 7, 20, 21 and 22. The RISØ P2445 cup-anemometer compared to a Thies 4.3303.22.000 cup-anemometer are shown, in average at all wind speeds, to be about 2% less at 30m height above ground level and 3% less at 8 m height. This difference between the RISØ and the Thies cup anemometers has given disputes between wind turbine manufacturers and testing institutes. It was therefore necessary to verify the field comparison results, and to analyse the dependency to turbulence.

At RISØ, a field comparison test rig was mounted on a 20m mast. The test set-up is shown in the following figure.



Figure 5-1 Anemometer comparison test setup with two RISØ P2546 cup anemometers separated 2m on a boom in the direction 15° to 195°, and with a sonic in the middle

The two cup anemometers for comparison are separated by 2m on a boom in the direction 15° to 195°, and with a sonic mounted in between. The boom on test rig was not made to yaw with the wind. In the SITEPARIDEN and CLASSCUP projects the RISØ P2445 cup anemometer was used. Today, in general, a newer version of the RISØ cup anemometer is used, the P2546 type which has a little different body shape, but the same rotor. This type is being used for the shown comparisons.

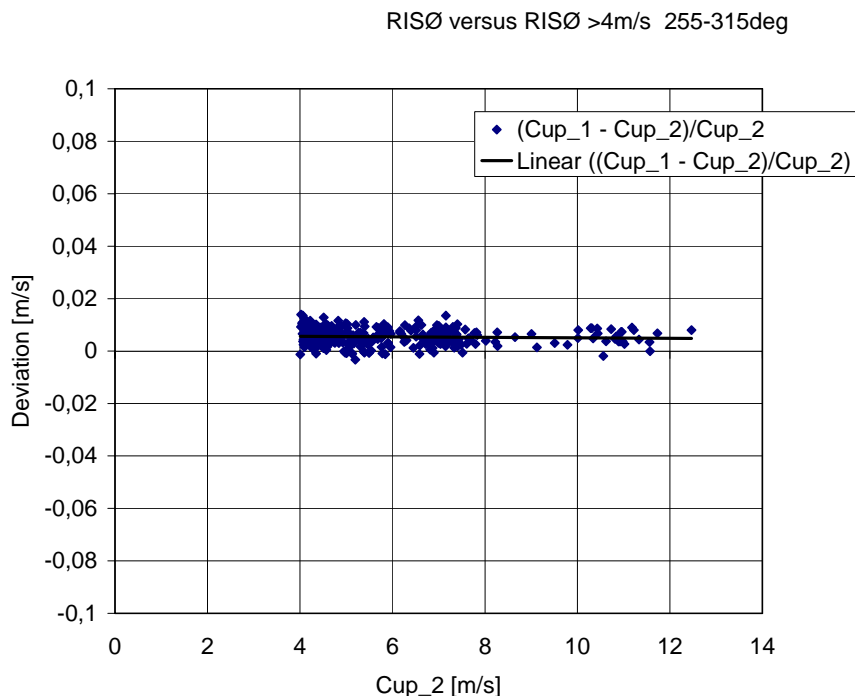

Figure 5-2 Relative deviation of a RISØ P2546 cup anemometer to another RISØ P2546 cup anemometer

The two compared RISØ P2546 cup anemometers show very little difference, see Fig. 5-2, and with an offset by less than 0,01m/s is seen. This difference is within the expected uncertainties from the wind tunnel calibrations of about 1%. Consequently, the field comparison is shown to be able to determine smaller deviations between the cup anemometers than wind tunnel calibrations.

Next, the RISØ and Thies cup anemometers were mounted on the test set-up. For varying turbulence intensities, the differences between the cup anemometers are shown in Fig. 5-3 and 5-4. All measurements are shown in Fig. 5-3, including measurements when one cup-anemometer is in the wake of another, and also when the whole set-up is in the wake of a nearby NKT 500kW wind turbine. The figure shows a substantial turbulence, and a high influence of turbulence in the measurements. A more restricted database without wake situations is shown in Fig. 5-4. These data show differences for wind speeds above 6m/s between 1% and 3%, and support the results made by DEWI in the SITEPARIDEN project.

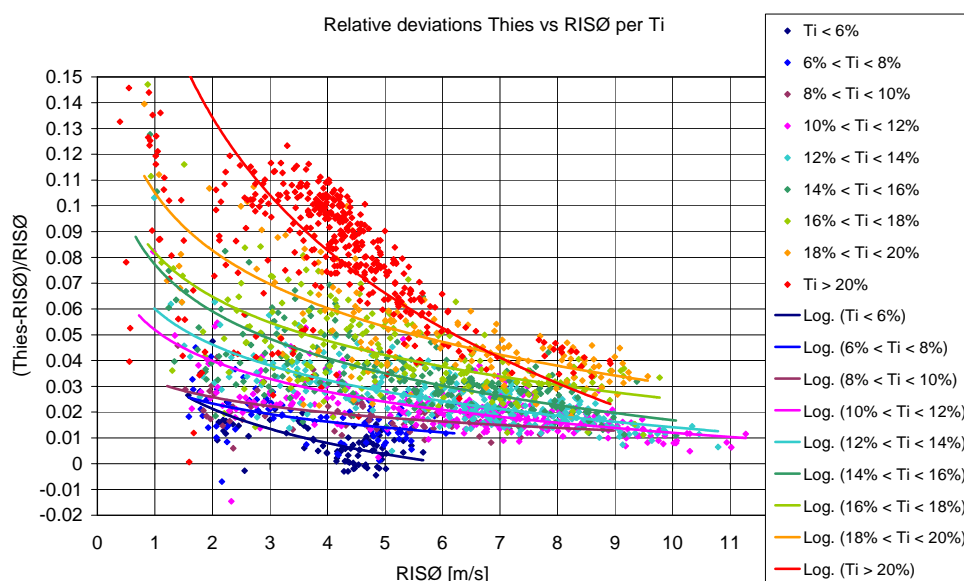

Figure 5-3 Relative deviations of Thies 4.3303.22.000 versus RISØ P2546 for all data, including wake situations

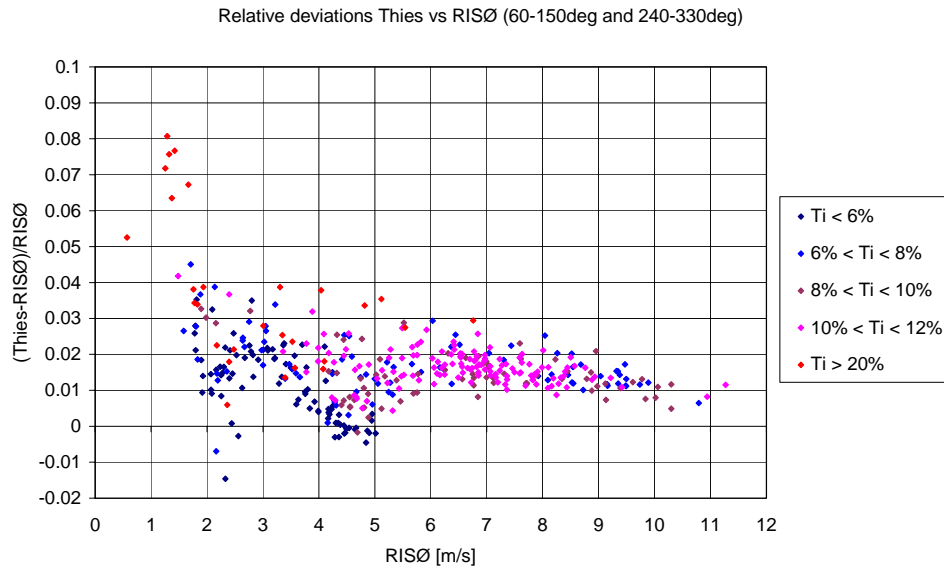

Figure 5-4 Relative deviations of Thies versus RISØ for restricted wind directions (90° on either side of the boom)

The high turbulence data were all filtered out in the former analysis, but it is interesting to see what the influence of high turbulence is. Therefore, the test set-up was changed so that the boom yawed with the wind. In this set-up, the sonic was also repositioned to a fixed boom below the top boom.

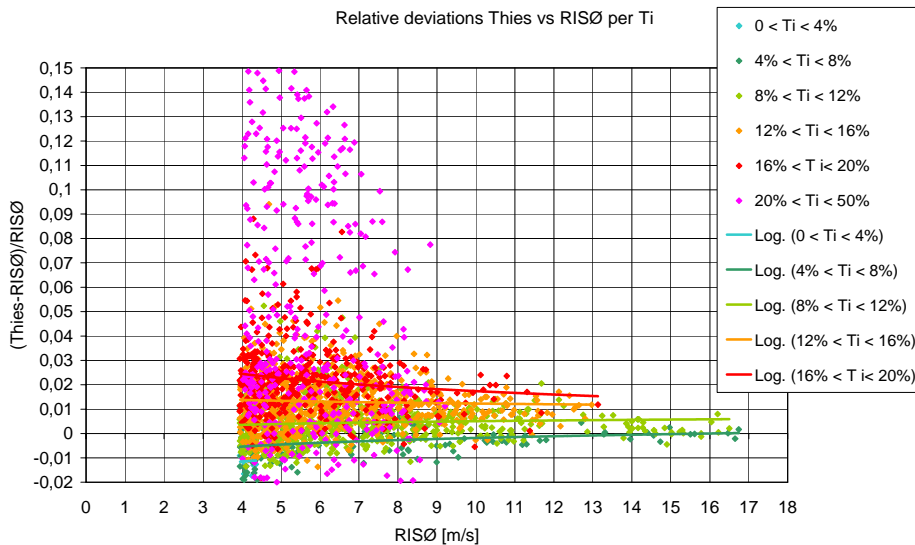

Figure 5-5 Relative differences between RISØ and Thies cup anemometers on improved set-up with yawing boom

Figure 5-5 show the results of the new database, where the boom yaws with the wind, but also where the reference RISØ cup anemometer was substituted. Only 10-min datasets within $\pm 15^\circ$ of the boom are selected. The data were binned with 4% turbulence bins, and were fitted to log-functions. It is seen in the figure that there is a substantial spreading of the data, but a definite influence of the turbulence intensity is seen. For medium turbulence intensity, 12-16%, the av-

erage difference is about 1.4% at all wind speeds. At higher wind speeds, 16-20%, the difference is about 2.4% at 4m/s going down to about 1.6% at 13m/s.

5.3 Cup anemometer angular response characteristics

The differences between the cup anemometers verified by DEWI were interpreted to be due to the angular characteristics of the cup-anemometers, Ref. 20 and 21. Angular characteristics have been measured several times in different wind tunnels over the last years, and are quite well known for many of the most used cup-anemometers. The following Fig. 5-6 shows measured angular characteristics of the RISØ P2445 and the Thies 4.3303.33.000 cup-anemometers in the FFA-LT5 wind tunnel (from the CLASSCUP project).

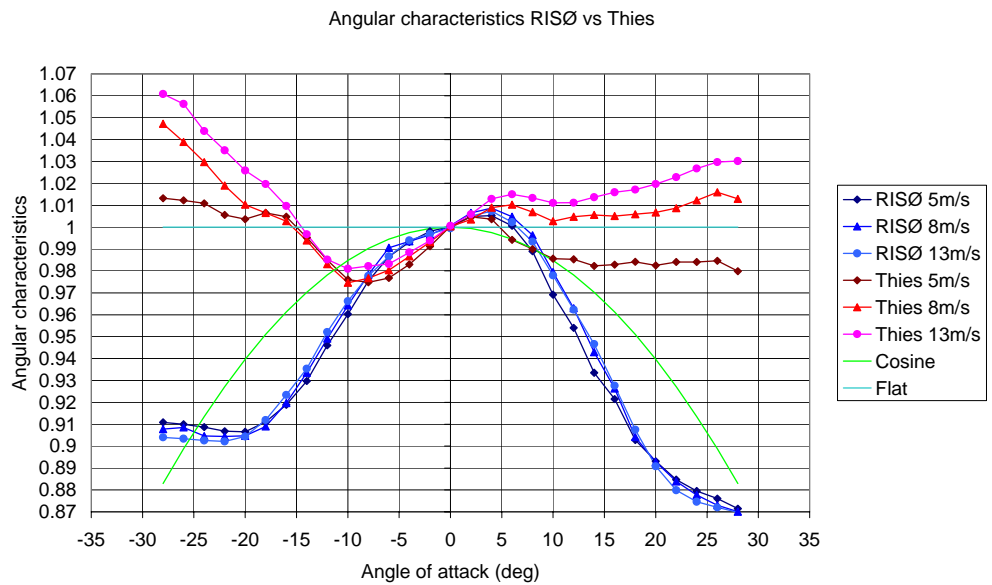

Figure 5-6 Angular characteristics of Thies compared to RISØ

The RISØ cup anemometer is having a reputation as a cup anemometer with horizontal characteristics, the Thies cup anemometer for vector characteristics. The measurements of angular characteristics show that none of the two cup-anemometers have ideal characteristics, which are either the flat or the cosine curves.

The Thies tend to overspeed compared to the flat curve at most angles of attack except for angles between -15° and 0° , where it underspeeds, compared to flat response characteristics. At low wind speed it also underspeeds from 5° to 28° . From -11° to 0° the Thies also underspeeds compared to the cosine response. From -7° to 0° it actually underspeeds compared to the RISØ cup-anemometer.

The RISØ cup-anemometer underspeeds compared to the cosine curve at angles from -25° to 0° and 7° to 30° . It overspeeds from 0° to 7° .

In flat terrain and for small angles of attack, i.e. small turbulence intensities, the two cup-anemometers must tend to average out their angular characteristics and ought to show the same average wind speed values, when only regarding their angular characteristics. In sloped terrain with inclined flow between -7° to 0°

and low turbulence the Thies should show minor values than the RISØ cup anemometer. The reason why this is not the case, is dynamic overspeeding.

5.4 Overspeeding

In the CLASSCUP project, a thorough analysis of overspeeding has been performed. In the FFA-LT5 wind tunnel, measurements on the influence of sinusoidal gusts have been made, and some cup anemometers have shown very surprising results. The results on measured overspeeding at the frequencies 2.5Hz to 3Hz are shown in Fig. 5-7 and 5-8. The RISØ cup anemometer actually did show negative or very small overspeeding for smaller turbulence intensities (10-16%). The Thies cup anemometer shown more “conventional” and expected overspeeding characteristics.

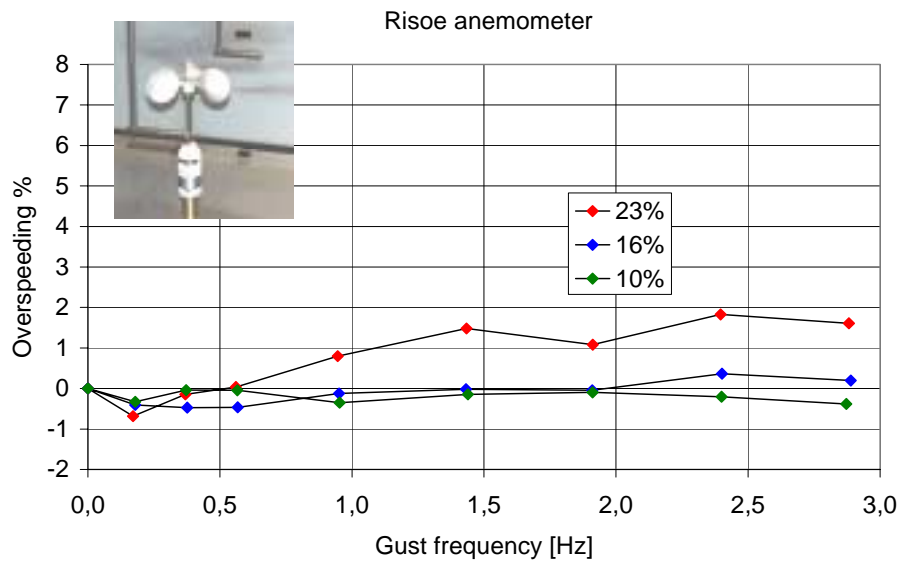

Figure 5-7 Gust runs with RISØ P2445 cup anemometer, FFA, Ref. 6

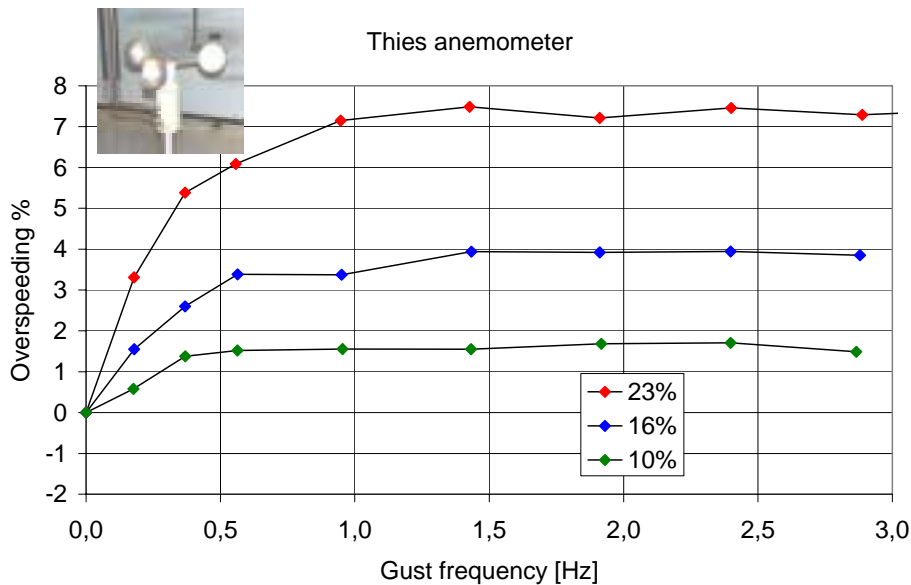

Figure 5-8 Gust runs with Thies 4.3303.22.000 cup anemometer, FFA, Ref. 6

The Thies cup anemometer has an increasing overspeeding up to a certain gust frequency, and at higher frequencies the overspeeding is constant. The RISØ cup anemometer has an overspeeding at 10% and 16% turbulence which varies within $\pm 0.5\%$. At 23% turbulence the overspeeding raises up to between 1 to 2%, but is not really stable. It is clearly seen, that the Thies is much more prone to overspeeding than the RISØ cup anemometer. The parameter that determines this behaviour is not only the distance constant. The distance constant of the Thies is about the double of the RISØ cup anemometer, which means, that the maximum overspeeding level is reached at about half the frequency of the RISØ. The maximum overspeeding level is determined by the shape of the torque curve of the cup anemometer, which is influenced by the rotor, hub and body design. The measurements in the CLASSCUP project indicate that the overspeeding has a much more important role than assumed earlier, and the SITEPARIDEN project indicate that the overspeeding dependency of vertical turbulence is very high and not understood at present.

5.5 Classification of cup anemometers

In general, cup anemometers introduce systematic errors when exposed to the real wind. These errors are due to the response of the cup anemometers to inclined flow, turbulence air density and temperature. Cup anemometers are mainly influenced through their friction in bearings, angular response and dynamic overspeeding. These errors can be systematically analysed under laboratory conditions, so that an estimate of the responses to ranges of external conditions can be verified and classified. The CLASSCUP project has proposed such a classification system for cup anemometers. The cup anemometers are exposed to ranges of external conditions, and the response to these conditions determines the classification. The external conditions are proposed to be within the ranges shown in the tables below for two different classification categories.

Table 5-1 Normal Range for classification

(Typical operational ranges for wind turbine power performance measurements at ideal sites)

Parameter	Normal range		
	Min	Ave	Max
Wsp (10min) [m/s]	4	4-16	16
Turb.int.	0.03	0.10	0.12+0.48/V
Turbulence structure $\sigma_u/\sigma_v/\sigma_w$.	1/0.8/0.5		
Length scale L_k [m]	100	500	2000
Air temp. [°C]	0	10	40
Air density [kg/m ³]	0.9	1.23	1.35
Slope [°]	-5	0	5
Ice, snow, rime conditions	not included		

Table 5-2 Extended Range for classification

(Typical operational ranges for wind turbine power performance verification measurements including complex terrain)

Parameter	Extended range		
	Min	Ave	Max
Wsp (10min) [m/s]	4	4-16	16
Turb.int.	0.03	0.10	0.12+1.13/V
Turbulence structure $\sigma_u/\sigma_v/\sigma_w$.	1/1/1		
Length scale L_k [m]	100	500	2000
Air temp. [°C]	-10	10	40
Air density [kg/m ³]	0.9	1.23	1.35
Slope [°]	-15	0	15
Ice, snow, rime conditions	excluded		

For the operational ranges, the bearing friction, the angular responses and the dimensionless torque curve of a cup anemometer should be determined. Friction should be measured in a climate chamber using a flywheel test. Angular responses should be determined by tilting the cup anemometer back and forth in a wind tunnel, and the dimensionless torque curve should be determined by measuring the torque at varying speed ratios around the equilibrium speed ratio.

When the above characteristics are known for the cup anemometers, the responses to all the ranges of external conditions can be calculated in time domain, using artificial 3D generated wind speed data and a well documented cup anemometer model. The systematic errors should then be plotted on a plot, as shown in Fig. 5-9 for a RISØ cup anemometer, evaluated as a “horizontal” cup anemometer, and in Fig. 5-10 for a Thies cup anemometer, evaluated as a “vector” cup anemometer. The class index ranges are defined by:

$$\text{Range} = \pm \text{IndexClass} * (0.1 \text{ m/s} + 0.01 * U) / 2$$

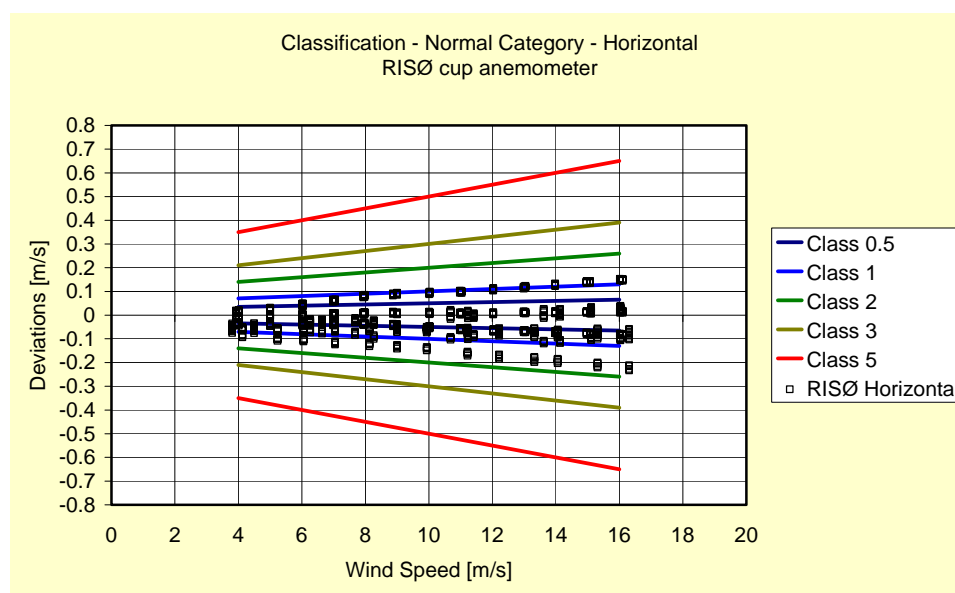

Figure 5-9 Evaluated class of a “horizontal” RISØ cup anemometer for a normal category after the method proposed in the CLASSCUP project

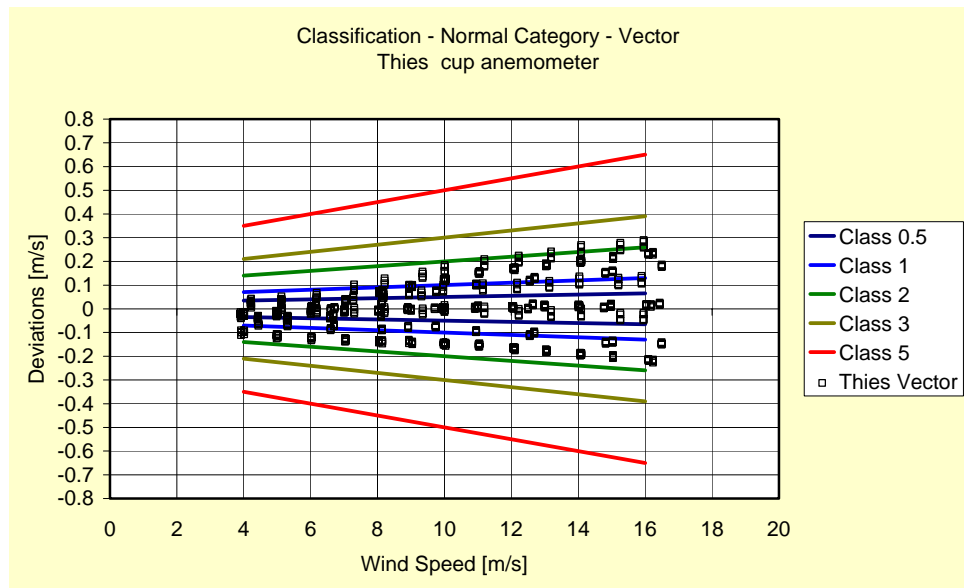

Figure 5-10 Evaluated class of a “vector” Thies cup anemometer for a normal category after the method proposed in the CLASSCUP project

It is essential to point out, that not only does the cup anemometers deviate systematically in field comparisons, they also deviate differently under different external conditions. It is therefore essential to estimate the absolute errors, and not just the relative difference in field comparisons. The classification system is a tool to estimate the absolute errors, and it is highly recommended to support such a classification system in power performance measurements.

5.6 Definition of measured wind speed

The definition of the measured wind speed can be made in several ways, and each way has a significant influence on the power performance measurement result in different kinds of terrain. The definition influences the way turbulence is taken into account in the measurement, and it influences the way inclined flow or skew air flow changes the power curve.

Definitions of measured wind speed relevant for power curve measurements are related to either the nature of the wind or to the nature of the wind turbine. Three of the definitions that are mentioned here considers the nature of the wind in a point and includes the average longitudinal wind speed, and adds one, two or three turbulence components in the definition. A fourth definition is based on an energy equivalent consideration over the swept area of the wind turbine rotor, and a fifth definition is based on a consideration of the wind that drives the wind turbine.

In general, a wind vector can represent the wind speed in a certain point of space (X, Y, Z) . In a Cartesian coordinate system with the X-axis and Y-axis in the horizontal plane the wind vector is a function of time:

$$\vec{U} = \begin{pmatrix} U_x(t) \\ U_y(t) \\ U_z(t) \end{pmatrix}$$

where U_X is the wind speed along the X-axis in the horizontal plane
 U_Y is the wind speed along the Y-axis in the horizontal plane
 U_Z is the wind speed along the vertical Z-axis

The wind is normally presented by quantities averaged over a time T. The different ways of defining the measured wind speed in relation to power performance measurements are mostly questions of how the three wind speed components in the wind vector are taken into account over the averaging period.

The wind itself is often treated statistically in a way that gives some representative values. The most important of these values is the average (horizontal) wind speed U:

$$U = \int_0^T \sqrt{U_X^2(t) + U_Y^2(t)} dt$$

The wind direction of U is the horizontal direction ϕ , defined by the geographic average direction from 0° in North and clockwise to 360°:

$$\phi = \int_0^T \text{Ar tan}(U_X / U_Y) dt$$

The average vertical wind speed W is:

$$W = \int_0^T U_Z dt$$

The wind inclination is the vertical direction φ , defined positive going upwards and negative going downwards:

$$\varphi = \text{Ar tan}(W / U)$$

The wind variations during the averaging time are the u, v and w components. The component u is the variations along the average wind speed U, i.e. in the horizontal direction ϕ , v is the variations lateral to U, and w is the variations in the vertical direction. The variations of u, v, w over the period T are represented by their standard deviations: σ_u , σ_v , σ_w

A statistical representation of the wind over an averaging time T is thus represented by the values: $(U, W, \sigma_u, \sigma_v, \sigma_w, \phi)$

Often, the wind speed is represented by the average values U, W and the variation components u, v, w over time;

$$\vec{U} = \begin{pmatrix} U_X(t) \\ U_Y(t) \\ U_Z(t) \end{pmatrix} = \begin{pmatrix} U + u(t) \\ U + v(t) \\ W + w(t) \end{pmatrix}$$

5.6.1 Vector scalar wind speed

The vector scalar wind speed definition in relation to power curve measurements is based on the assumption, that the important wind parameters are all the wind components U_X , U_Y , U_Z . The measured average wind speed becomes:

$$U_{vector} = \int_0^T \sqrt{U_X^2(t) + U_Y^2(t) + U_Z^2(t)} dt = \sqrt{U^2 + W^2}$$

5.6.2 Horizontal wind speed

The horizontal wind speed definition is based on the assumption, that the important wind parameters are the horizontal components. The measured average wind speed is therefore:

$$U_{horiz} = \int_0^T \sqrt{U_x^2(t) + U_y^2(t)} dt = U$$

5.6.3 Longitudinal wind speed

The longitudinal wind speed definition is based on the assumption that the wind turbine only responds to average longitudinal (and horizontal) wind, in which only the components in the longitudinal direction ϕ are taken into account:

$$U_{long} = \int_0^T \sqrt{U_x^2(t) + U_y^2(t)} \cos(\text{Ar tan}(U_x / U_y) - \phi) dt$$

In modelling power performance of wind turbines with blade element codes, actuator disc codes, CFD codes, or WAsP codes the input wind speed to the codes is most often the average longitudinal wind speed. If turbulence is added, it is still the average longitudinal wind speed that is indicated on the output plots but added and information on the turbulence level.

5.6.4 Energy equivalent wind speed

The energy equivalent wind speed definition in relation to power curve measurements is based on the assumption that the wind turbine is an energy based machine, and the wind speed shall be representative to the energy flux in the wind, Frandsen, Ref. 8:

The “energy equivalent” wind speed, U_{energy} , is the equivalent non-turbulent flow speed that yields the same energy flux through a unit-area perpendicular to the mean flow direction as the real flow

The power in the wind per unit swept area is:

$$\begin{aligned} P &= \overline{q \cdot (U + u)} = \frac{1}{2} \rho \cdot ((U + u)^2 + v^2 + w^2) \cdot (U + u) \\ &= \frac{1}{2} \rho \cdot (U^3 + 3U^2u + U(3u^2 + v^2 + w^2) + u(u^2 + v^2 + w^2)) \end{aligned}$$

where q is the kinetic energy

From the formula of the power, the energy equivalent wind speed can be expressed as:

$$U_{energy} = \left(\overline{((U + u)^2 + v^2 + w^2) \cdot (U + u)} \right)^{1/3}$$

Since $\overline{u} = 0 \Rightarrow \overline{3U^2u} = 0$, and since $\overline{u(u^2 + v^2 + w^2)}$ is one order of magnitude less than the remaining terms, and therefore set to zero, the expression reduces to:

$$P \approx \frac{1}{2} \rho \cdot \left(U^3 + 3U\overline{u^2} + U\overline{v^2} + U\overline{w^2} \right) = \frac{1}{2} \rho \cdot U^3 \left(1 + 3\frac{\overline{u^2}}{U^2} + \frac{\overline{v^2}}{U^2} + \frac{\overline{w^2}}{U^2} \right).$$

We have per definition $\sigma_v^2 = \overline{v^2}$, $\sigma_w^2 = \overline{w^2}$ and $\sigma_u^2 = \overline{u^2}$, which reduces P to:

$$P \approx \frac{1}{2} \rho \cdot U^3 \left(1 + 3\frac{\sigma_u^2}{U^2} + \frac{\sigma_v^2}{U^2} + \frac{\sigma_w^2}{U^2} \right).$$

Thus, with the assumptions made, the energy equivalent wind speed is approximated by:

$$U_{energy} \approx U \left(1 + 3 \frac{\sigma_u^2}{U^2} + \frac{\sigma_v^2}{U^2} + \frac{\sigma_w^2}{U^2} \right)^{\frac{1}{3}}$$

Assuming the turbulence to be isotropic, $\sigma_u = \sigma_v = \sigma_w$ then the power in the wind per unit swept area becomes:

$$P \approx \frac{1}{2} \rho \cdot U^3 (1 + 5 \cdot T_i^2)$$

where T_i is the turbulence intensity: σ_u / U

5.7 Types of wind speed sensors

The relevant wind speed sensors that are considered in the following are all based on cup anemometers, although sonic anemometers are able to establish any of the wind speed definitions from an analysis of measured data, but they are at present not accepted in power performance measurements, mainly because of high directional sensitivity to average wind speed measurements and no international accepted calibration procedure.

5.7.1 Vector scalar wind speed cup anemometer

Vector scalar wind speed cup anemometers are cup anemometers that measure ideally vector scalar wind speeds U_{vector} . They are characterized by flat angular characteristics.

In sloped terrain the vector scalar cup anemometer will measure power curves with a significant decrease of AEP compared to flat terrain.

It was shown in practice and verified by field measurements in the CLASSCUP project, Ref. 6, that it is possible to make very flat angular response curves, even to very high angles of attack ($\pm 40^\circ$). The prototype cup anemometers made in this project, though, had unexpectedly high overspeeding characteristics.

5.7.2 Horizontal wind speed cup anemometer

Horizontal wind speed cup anemometers measure ideally horizontal wind speeds $U_{horizon}$. They are characterized by cosine angular characteristics.

For isotropic turbulence, horizontal wind speed cup anemometers are just as sensitive to turbulence as a wind turbine, according to blade element code considerations, i.e. the wind turbine becomes “insensitive” to turbulence.

In sloped terrain the horizontal wind speed cup anemometer will measure power curves with a slight decrease of AEP compared to flat terrain.

The experience from the CLASSCUP project, Ref. 6, showed that a cosine angular response and low overspeeding might both be optimised for a horizontal wind speed cup anemometer.

5.7.3 Longitudinal wind speed cup anemometer

A longitudinal wind speed cup anemometer measure ideally longitudinal wind speeds U_{long} . Such an instrument is a combined instrument, including a horizontal wind speed cup anemometer and a wind vane. The lateral turbulence compo-

ment is out-compensated with the wind vane by online corrections. Such a prototype instrument has been produced and implemented by Kristensen, Ref. 23. The wind vane was mounted beneath the cup anemometer rotor as an integral part of the sensor.

In sloped terrain the longitudinal wind speed cup anemometer will measure power curves with a slight decrease of AEP compared to flat terrain, exactly as the horizontal wind speed anemometer.

5.7.4 Energy equivalent wind speed sensor

An energy equivalent wind speed sensor measure ideally energy equivalent wind speeds U_{energy} . At present it is not known which kind of cup anemometry that would be able to measure energy equivalent wind speeds.

5.7.5 Differences between the different definitions of wind speed

The order of differences between the various wind speed definitions has been analysed from sonic measurements by Pedersen, Ref. 19, with measured data from typical inland and offshore sites. The following four figures show the differences as a function of turbulence intensity.

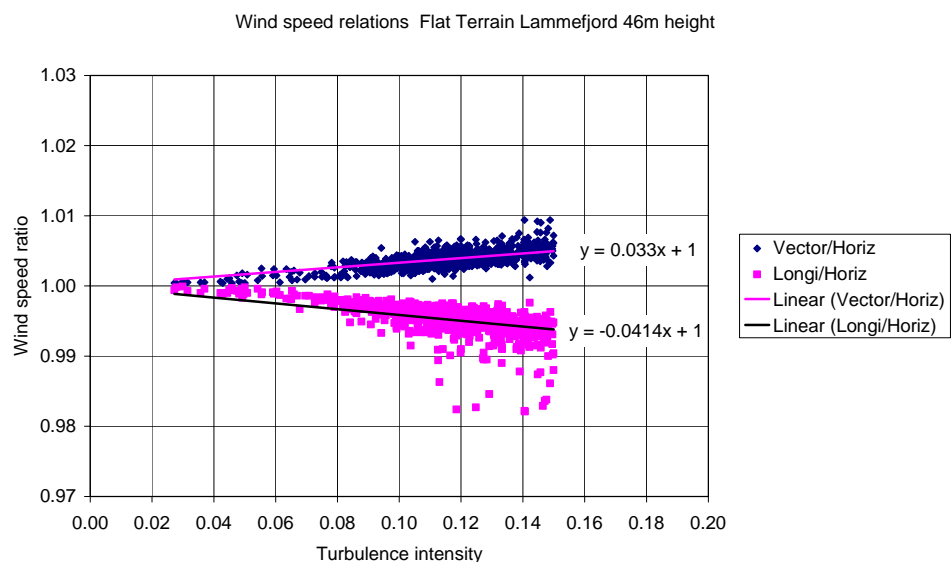

Figure 5-11 Relative differences of definition of measured wind speed, based on sonic data week 40-41 1987 from flat inland terrain at Lammefjord, Denmark, 46m above terrain

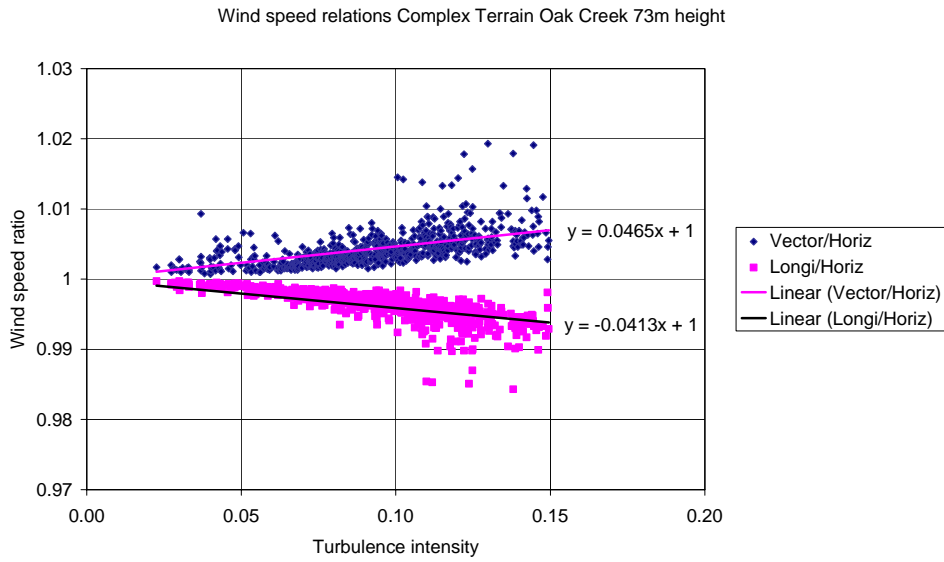

Figure 5-12 Relative differences of definition of measured wind speed, based on sonic data week 17-18 1999 from complex terrain at Oak Creek, California, 73m above terrain

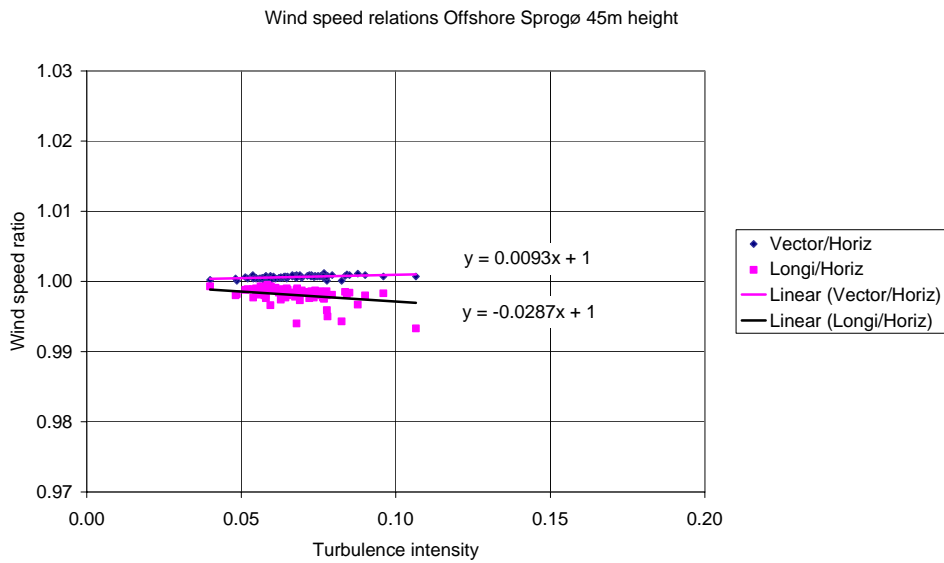

Figure 5-13 Relative differences of definition of measured wind speed, based on sonic data week 51-52 1990 from offshore measurements at Sprogø, Denmark, 45m above water

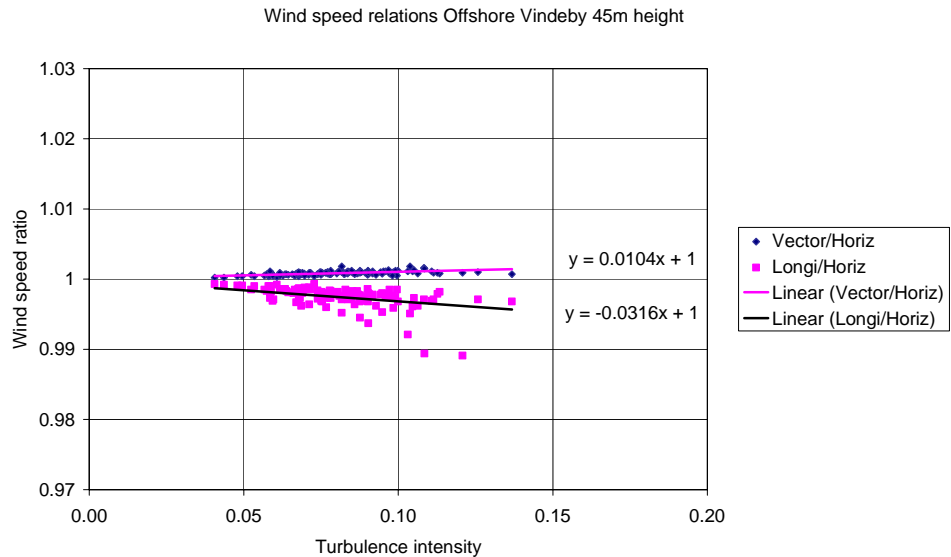

Figure 5-14 Relative differences of definition of measured wind speed, based on sonic data week 44-45 1994 from offshore measurements at Vindeby, Denmark, 45m above water

It is clearly seen by the linearity of the plots, that there is a systematic difference between the different definitions of wind speed. For the flat terrain and complex terrain measurements, the difference between both the 1D and 2D measurement and the 2D and 3D measurement is in the order of 0,5% at 10% turbulence and 1% at 20% turbulence. For offshore sites the differences are much lower. The detailed average differences at 10% and 20% turbulence are shown in Table 5-3. It is seen from the table, that the differences due to different definitions of wind speed are quite low compared to the differences measured in the cup anemometer field comparisons.

Table 5-3 Average difference for different definitions of measured wind speed

	Vector rel. to horizontal Turbulence		Longitudinal rel. to horizontal Turbulence	
	10%	20%	10%	20%
Complex Oak Creek	+0.47%	+0.93%	-0.41%	-0.82%
Flat inland Lammefjord	+0.33%	+0.66%	-0.41%	-0.82%
Offshore Vindeby	+0.09%	+0.18%	-0.29%	-0.57%
Offshore Sprogø	+0.10%	+0.20%	-0.32%	-0.64%

The differences on a flat inland site at Lammefjord at 46m height, a complex terrain site at Oak Creek at 73m height, an offshore site at Vindeby at 45m height and an offshore site at Sprogø at 70m height thus shows the following relationships:

$$\begin{aligned}
 U_{vector} &= U_{horiz} \cdot (1 + 0.0330 \cdot T_i) = U_{long} \cdot (1 + 0.0744 \cdot T_i) && \text{Lammefjord} \\
 U_{vector} &= U_{horiz} \cdot (1 + 0.0465 \cdot T_i) = U_{long} \cdot (1 + 0.0878 \cdot T_i) && \text{Oak Creek} \\
 U_{vector} &= U_{horiz} \cdot (1 + 0.0093 \cdot T_i) = U_{long} \cdot (1 + 0.0380 \cdot T_i) && \text{Vindeby} \\
 U_{vector} &= U_{horiz} \cdot (1 + 0.0104 \cdot T_i) = U_{long} \cdot (1 + 0.0420 \cdot T_i) && \text{Sprogø}
 \end{aligned}$$

At 10% turbulence the difference in the three definitions is less than 0.9%, and at 20% turbulence it is less than 1.8%. In all practical applications the question on definition of measured wind speed, from a turbulence point of view, is thus less than 2%.

5.8 Conclusions and recommendations

From the experience with cup anemometry the following conclusions and recommendations can be made:

- Cup anemometers show systematic turbulence dependent differences in field comparisons
- Neither the RISØ nor the Thies cup anemometer has any “ideal” angular characteristics for “Horizontal” or “Vector” instruments
- The difference in measured wind speed between the two definitions “vector” and “horizontal” is quite low (about 1% at 20% turbulence), and is not the explanation to the high differences shown in the field comparisons
- Angular response is not enough to explain the differences of the cup-anemometers in field comparisons.
- Dynamic overspeeding is a substantial factor that must be taken into account
- Dynamic overspeeding of cup-anemometers is more complex than previously thought. For an adequate analysis, a non-dimensional torque curve must be provided
- The RISØ cup anemometer seems to have a little negative overspeeding at 10% turbulence, but increasing positive overspeeding at higher turbulence intensities.
- The Thies cup-anemometer seems to have substantially higher overspeeding than the RISØ cup anemometer, which must be an important part of the explanation of the high differences in field comparisons
- Cup anemometers should, apart from field comparisons, be classified according to a classification system, and based on an analysis of their friction dependency, angular response and dynamic overspeeding effects under well-defined ranges of external climatic conditions. A classification system is proposed in the CLASSCUP project
- Such a classification system should be widely adopted in the wind energy community, and it should be used to estimate operational uncertainties in power performance measurements (uncertainty $u_{v2,i}$ in the power performance measurement standard IEC 61400-12)
- The definition of the measured wind speed should with respect to inclined flow be based on the following considerations:
 1. Influence of flow inclination (sloped terrain and without turbulence)
 2. Influence of turbulence on the wind turbine and the wind speed sensor

5.9 Danish requirements to cup anemometry in power performance measurements

The differences between cup anemometers being used in power performance measurements have lead to some recommendations to cup anemometers set up by the Danish Approval Scheme for Wind Turbines, Ref. 24. The recommendations requires the horizontal wind speed to be used, and refer to cup anemometer characteristics such as angular characteristics, maximum overspeeding level, distance constant, friction in bearings, rotational symmetric characteristics, and electromagnetic compatibility. The recommendations also require some more or

less well defined geometric conditions to be fulfilled. Finally, a field comparison with another cup anemometer that do meet the requirements is required. Deviations may not exceed 1% from this cup anemometer.

6. Influence of flow inclination and turbulence on power performance measurements

The influence of skew airflow on the power performance measurement has been analysed in detail. The results were reported in a note, that was presented to the IEC-TC88-MT12 group on power performance measurements, Ref. 25. The following presentation based on this note.

6.1 Introduction

In all measurements it is essential to define the measurand (a well-defined physical quantity) precisely. The less doubt about the definition, the less uncertainty. In defining the measurand precisely, the uncertainty in the definition itself is taken out of the uncertainty of the overall measurement, but secondly, specifications and improvement of the set-up and sensors to use, can be focused.

The definition of one of the primary measurands in power performance measurements, the measured wind speed, is not defined in a consistent and satisfactory way. This lack of definition is partly responsible for the large deviations in wind speed measurements in different types of terrain.

In the discussions on the definition of measured wind speed, one should divide the discussions into two parts. The first part should consider the influence on the wind turbine and the wind speed sensor from the average airflow over the terrain. In this case, flow speeds and flow directions of the air are the only factors to consider. The second part should consider the influence from turbulence on the wind turbine and the wind speed sensor.

6.2 Influence of skew airflow

First of all, let us consider the smooth flow over the terrain. If taking no considerations as to the influence of turbulence, the considerations all concentrate on flow directions and flow speeds in the terrain around the wind turbine at the height of the rotor.

6.2.1 Wind turbine response to skew air flow

In power curve measurements where the flow is deviating from the ideal flow along the axis of horizontal axis wind turbines, the result of the measurements is very dependent on how the wind turbine responds to skew airflow.

Horizontal axis wind turbines represent almost vertical discs located in the terrain, but the discs are tilted a little, corresponding to the tilt angle of the shaft. When wind directions change, the discs turn toward the wind direction. Misalignment due to design flaws or defects of the yawing system of the wind turbine is considered to be part of the construction. If for instance, a wind turbine has a systematic yaw error, the power is reduced, but no correction is made in

the power performance measurements for this yaw-misalignment. Madsen, Ref. 26, has studied the reduction of power production for varying yaw angles. He measured the power reduction on a 75kW experimental wind turbine for different yaw angles at 8-9 m/s. Then he calculated the power reduction with aerodynamic codes. The calculations were based on the HawC code, using both the standard finite blade element BEM theory, and another method, deriving the aerodynamic induction with a detailed 3D actuator disc model. The results are shown in the following figure.

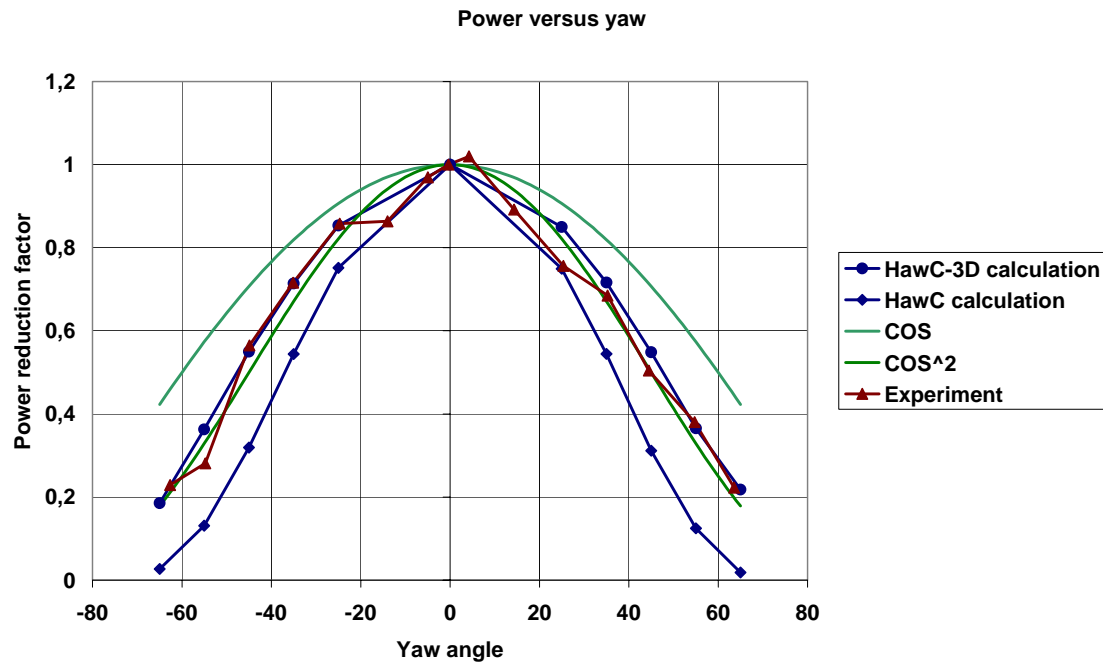

Figure 6-1 Measured and calculated relative power reduction for an experimental 75kW wind turbine at 8-9 m/s from Ref. 26

The power is reduced significantly with the skew airflow. The assumption of a cosine relationship of the power to the yaw angle due to decreased projected swept area to the wind is too optimistic at this wind speed. The decrease is substantially higher. The measurements and calculations indicate that the variation is very close to a \cos^2 -relationship. The relationship is documented very well with both HawC-3D calculations and the measurements at the higher yaw angles. At smaller yaw angles, though, the measurements seem to deviate somewhat. This might be due to a database that is too small.

The \cos^2 relationship might be explained with the fact, that not only the projected swept area is reduced with the cosine; but also the flow component perpendicular to the rotor is reduced with a cosine.

The reduction of power with the yaw angle is almost the same as for inclined airflow. The difference is the wind shear, and the effect is very low. For the present analysis we can make the assumption that misalignment of the flow relative to the rotor axis is \cos^2 related for yaw, tilt and slope angles. Under this assumption, it is possible to make some simple calculations of the consequences of different ways of performing performance measurements in different kinds of terrain.

6.2.2 Power curve measurements in flat horizontal terrain

In flat and non-inclined terrain there seems to be little doubt how power curves should be measured. Precise measurements of horizontal wind speed at one point at hub height seem to define well the average wind speed that drives the rotor. In fact, all wind speeds over the swept area of the wind turbine should be integrated to determine the average wind speed, but no efficient procedure to do the job has been proposed. The yawing of the wind turbine, or the misalignment of the wind turbine due to bad yawing, is not considered a problem of the measurement set-up, but is considered a design flaw of the wind turbine, a feature that is the responsibility of the designer. If the wind turbine is yawing badly, the punishment is seen in the power curve. If bad yawing is verified in the measurements, the designer might make changes to the wind turbine. Tilting of the rotor is also considered a design feature of the wind turbine, which is not taken into account in the power curve measurement. The power is not increased by a factor to refer to the power that would be the output if the rotor were pointed directly into the wind, and the wind speed is not reduced to take account of only the component that is parallel to the wind turbine shaft axis.

The consequences of using different definitions of the wind speed are now considered in the flat terrain. Consider the wind turbine rotor to be a disc with a radius that is the outermost tip radius of the rotor, and the disc being perpendicular to the rotor axis. The disc is tilted with the tilt angle of the rotor axis. It is assumed that the power of the rotor disc is responding to yaw, tilt and slope angles with a \cos^2 relation. This relation is assumed to be due to a cosine reduction in projected swept area and a reduction of wind speed perpendicular to the rotor disc, assuming C_p to be kept constant.:

$$P = \frac{1}{2} \rho C_p A V^3 \cos^2(\alpha) \Leftrightarrow P = \frac{1}{2} \rho C_p (A \cos(\alpha)) \cdot (V \cos^{1/3}(\alpha))^3$$

The interpretation of this formula is, that the power curve should be corrected both in power and in wind speed, instead of being corrected in power alone. The power should be corrected with a decrease according to the cosine relationship, and the wind speed should be corrected with an increase according to the cubic root of the cosine relationship. The consequence of this way of converting a power curve is that the stall power of a stall regulated wind turbine is only changed with the cosine relationship at varying yaw angles at higher wind speeds. The assumptions of the \cos^2 relationship and the conversion of power curves with skew air flow needs further verification, but for the present analysis, the assumption is plausible from the theoretical considerations, and it is supported from the study in Ref. 26.

In the following, we consider the power curve measured in flat terrain as a reference for measurements in other types of terrain. The reference power curve measured in this terrain is:

$$PC_{ref}(V_{ref}, P_{ref}) = (V_{axis} \cdot \cos^{-1/3}(\sqrt{\alpha^2 + \gamma_{flat}^2}), P_{axis} \cdot \cos(\sqrt{\alpha^2 + \gamma_{flat}^2}))$$

where

- PC_{ref} is a reference power curve function of two variables, wind speed and power
- V_{ref} is the flow wind speed of reference power curve in flat terrain
- P_{ref} is the power of reference power curve in flat terrain
- V_{axis} is the flow wind speed when converted to an axial flow power curve
- P_{axis} is the power when converted to an axial flow power curve

- α is the tilt angle
- γ_{flat} is the yaw error in flat terrain

6.2.3 Power curve measurements in sloped terrain

When there is a slope in the terrain, but with otherwise totally smooth surroundings, the situation changes. One can say, that an additional tilting of the wind turbine rotor has been introduced, and this has some consequences. One has to choose whether this situation is now changing the power curve, or the power curve under these circumstances should be corrected to be the same as the power curve in flat terrain. If a power curve measured in sloped terrain is compared to a power curve measured in flat terrain, it can easily be made if the power curve measured in sloped terrain is already “intrinsically corrected” to correspond to flat terrain conditions. If it is not “intrinsically corrected”, one must convert the power curve to flat terrain conditions, and conversion methods must be made available before a comparison (verification) can be made.

In a sloped terrain with inclined flow, the measured power curve, based on a vector scalar wind speed definition, would be:

$$PC_{\text{vec}}(V_{\text{vec}}, P_{\text{vec}}) = (V_{\text{axis}} \cdot \cos^{-1/3}(\sqrt{(\alpha + \beta)^2 + \gamma_{\text{slope}}^2}), P_{\text{axis}} \cdot \cos(\sqrt{(\alpha + \beta)^2 + \gamma_{\text{slope}}^2}))$$

- where PC_{vec} is a power curve function of two variables, measured with a vector scalar definition on measured wind speed
- V_{vec} is the wind speed measured by a vector scalar cup anemometer in sloped terrain
- P_{vec} is the measured power in sloped terrain
- β is the flow inclination angle
- γ_{slope} is the yaw error in sloped terrain

If, in the same sloped terrain, the measured power curve was based on a horizontal wind speed definition, the power curve would be:

$$PC_{\text{hor}}(V_{\text{hor}}, P_{\text{hor}}) = (V_{\text{axis}} \cdot \cos(\beta) \cdot \cos^{-1/3}(\sqrt{(\alpha + \beta)^2 + \gamma_{\text{slope}}^2}), P_{\text{axis}} \cdot \cos(\sqrt{(\alpha + \beta)^2 + \gamma_{\text{slope}}^2}))$$

- where PC_{hor} is a power curve function of two variables, measured with a horizontal definition on measured wind speed
- V_{hor} is the wind speed measured by a horizontal cup anemometer in sloped terrain
- P_{hor} is the measured power in sloped terrain
- β is the flow inclination angle
- γ_{slope} is the yaw error in sloped terrain

6.2.4 AEP differences of power curves measured in flat and sloped terrain

We will now use an example power curve to get a figure of the amount of error in AEP that is introduced in sloped terrain using the two different wind speed definitions; the vector scalar and the horizontal. An Excel sheet has been made to make the calculations. The measured power curve from IEC 61400-12, Ref. 1, is the reference power curve $PC_{\text{ref}}(V_{\text{ref}}, P_{\text{ref}})$. The power curve is assumed measured in flat terrain without any turbulence. The yaw errors in flat and sloped terrain, γ_{flat} and γ_{slope} , are assumed to be zero and the tilt angle is assumed to

to be 5°. The power curves as they would be measured in sloped terrain are calculated from the formulas in the former chapters.

From the power curves, AEP is calculated for a Rayleigh distributed wind resource with an average wind speed of 8 m/s and no turbulence. An example of a calculated power curve is shown in the following figure for a flow inclination angle of 15°. The results of the AEP calculations are shown in Table 6-1.

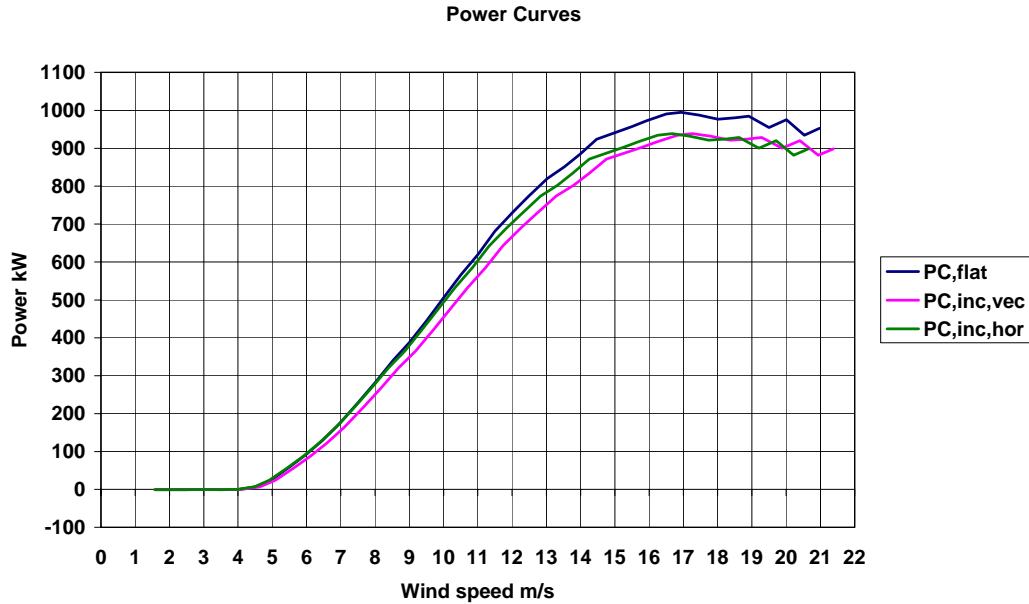

Figure 6-2 Simulated power curves, based on Ref. 1, as measured in flat and sloped terrain with 15° inclined flow using vector scalar or horizontal defined wind speeds

Table 6-1 Simulated AEP in flat and inclined flow in sloped terrain for simulated power curves, based on Ref. 2, with vector scalar and horizontal defined wind speeds and Rayleigh distributed 8m/s average wind speed and no turbulence

Power curve	PC, flat kWh	PC, inc, vec kWh	PC, inc, hor kWh	Difference vector scalar	Difference horizontal
Slope 0°	1,350,571	1,350,571	1,350,571	0%	0%
Slope 5°	1,350,571	1,326,035	1,335,087	-1,8%	-1.1%
Slope 10°	1,350,571	1,285,570	1,321,225	-4,8%	-2.2%
Slope 15°	1,350,571	1,229,832	1,308,349	-8.9%	-3.1%
Slope 20°	1,350,571	1,159,749	1,295,455	-14.1%	-4.1%

The difference in AEP from flat to sloped terrain power curves is seen to increase for both definitions of wind speed, but for higher slope angles and for the vector scalar wind speed, the difference is substantially increasing at higher slope angles.

For a defined “ideal site”, as described in IEC 61400-12, Ref. 1, the maximum average slope is 3° . Including the influence of a tilting angle of 5° , this leads to AEP differences of -0.95% and -0.70% differences for the vector scalar and horizontal definitions, respectively. Realistically, the flow might at an “ideal site” be 5° , which leads to AEP differences of -1.8% and -1.1%, respectively. At these slope angles, the verification of performance seems to give small problems.

6.2.5 Site calibration in smooth sloped terrain

Slope angles above 3° are high enough that site calibrations are required. So, let us consider the situation when site calibrations are included.

A site calibration in a sloped terrain has two wind speed sensors at hub height in the smooth flow over the terrain. This set-up would result in the same conditions for both cup anemometers for any given wind direction. The site calibration correction factors would all be 1.0 from all wind directions since the anemometers have the same flow inclination angles and the same measured wind speeds, assuming that the cup anemometers have the same angular characteristics.

If the cup anemometers had different angular characteristics, for instance one having a flat and the other a cosine response curve, the site calibration correction factors would be different from different directions. In this case, the correction factors would not be flow correction factors, but “artificial” flow correction factors that express differences in the cup anemometer angular characteristics. If the site calibration shall define flow correction factors, then it must be required, that the flow is defined as either vector scalar wind speeds or horizontal wind speed, and cup anemometers shall be of same type with same angular characteristics.

6.2.6 Site calibration and power curve measurements in complex terrain

Let us now turn our eyes towards a site calibration in a more realistic complex terrain site. A wind turbine might be positioned at one place where the flow has an inclination angle and flow speed, which is very different from the inclination angle and flow speed at the cup anemometer.

If the cup anemometers have ideal characteristics, flat or cosine angular response, the flow correction factors correspond to vector scalar or horizontal wind speeds. The flow correction factors would be “real” flow correction factors of vector scalar or horizontal wind speeds. If the cup anemometers are of different type or have non-ideal angular characteristics, the flow correction factors would be “artificial”. The correction factors would be “infected” by the angular characteristics of the cup anemometers, and this effect is found to be very high for various commercial cup anemometers.

In the case, where the wind turbine is on the top of a hill, the flow inclination would be close to zero, and for the wind turbine, the situation would correspond to flat terrain. The cup anemometer, being substituted at the wind turbine position, would respond as in flat terrain, and not be dependent on the angular characteristics of the cup anemometer (still not considering any turbulence). The mast cup anemometer would respond differently and be influenced by the angu-

lar characteristics of the cup anemometer. If real flow correction factors are wanted, then cup anemometers shall have ideal angular characteristics, and one has to decide whether this flow correction is based on the “vector scalar” flow or the “horizontal flow”. Otherwise, a site calibration should only be considered as an “internal” part of a power curve measurement, and should not be reported separately as a “site calibration” which is very misleading.

Especially in complex terrain, the flow inclination angles are very difficult to estimate at wind turbine rotor centres. There are steep slopes and three-dimensional effects, which are difficult to estimate, even with flow calculation models. In complex terrain, the wind turbines are often positioned at the top of the ridges, but a lot of the wind turbines are also positioned on the slopes of the ridges. Terrain slopes of 10° are not uncommon.

Another effect, which is seen in complex terrain, is that the yaw error of the wind turbine is dependent on the flow inclination angle. Manufacturers often put their wind vanes on the back of the nacelle. In this position, the flow over the nacelle is sensitive to the flow inclination angle. Such yaw errors would be very interesting to know, especially for the wind turbine designer, who could change the design, but yaw errors are normally not part of the power curve measurement. This is due to the fact, that yaw errors are considered part of the design, and is not taken into account in power performance verification.

Yaw errors can easily be measured in a power performance measurement where a site calibration is included. During the site calibration, the flow direction changes from the two masts can be measured. The yaw position can afterwards be measured on the wind turbine. The yaw error can be found from the yaw position and the wind direction measured on the mast, corrected by the wind direction changes, measured during site calibration.

6.3 Influence of turbulence

Turbulence influences both the cup anemometer and the wind turbine in the order of a few to five percent. This is still an important contribution to the overall result of a power curve measurement. In the following, the influence of turbulence is considered on the wind turbine and the cup anemometer.

6.3.1 Influence of turbulence and inclined flow on the cup anemometer

Cup anemometers are influenced by turbulence in two ways; overspeeding and angular characteristics. Overspeeding might increase the reading by several percent, as has been shown earlier, but in the present study it is not taken into account. It could be argued that the overspeeding in flat and sloped terrain cancels out in when AEP from the power curves are subtracted.

In the following, the focus on the influence of turbulence will be on the angular characteristics of the cup anemometer.

The turbulence changes the flow inclination to the cup anemometer, and over a period of 10 minutes, changes the signal, except if it has ideal characteristics for the defined measured wind speed. If a cup anemometer has flat angular characteristics and the defined wind speed is the vector scalar wind speed, then it has no dependency on turbulence. The same is valid for a cosine angular character-

istics and a horizontal defined wind speed. If, on the other hand, a cup anemometer with flat angular characteristics is used with a horizontal definition, there is a systematic difference in the measurements as shown in Fig. 6-3. The corresponding systematic error is shown in Fig. 6-4 for a cup anemometer with cosine angular characteristics is used with a vector definition.

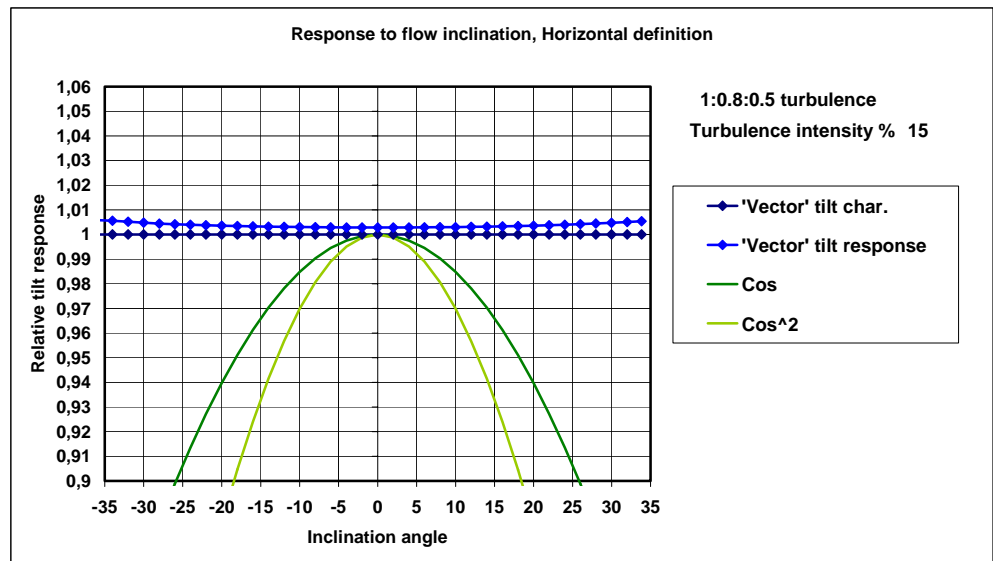

Figure 6-3 Angular response characteristics of “ideal vector scalar” cup anemometer with horizontal wind speed definition

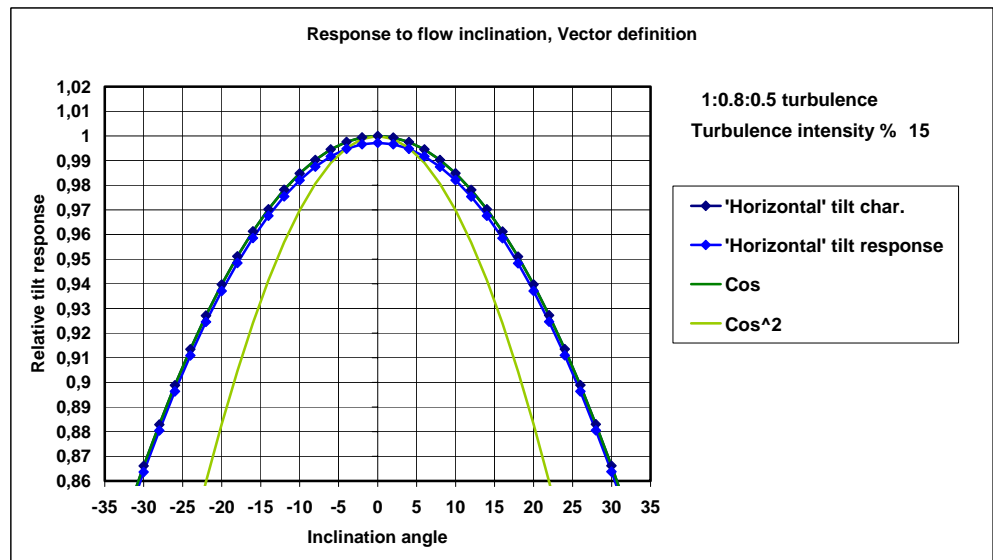

Figure 6-4 Angular response characteristics of “ideal horizontal” cup anemometer with vector scalar wind speed definition

Fig. 6-5 to 6-6 show the influence of turbulence on angular characteristics with horizontal definition of wind speed on two commercial cup anemometers, and Fig. 6-7 to 6-9 show angular characteristics with vector scalar definitions of wind speed for three different commercial cup anemometers.

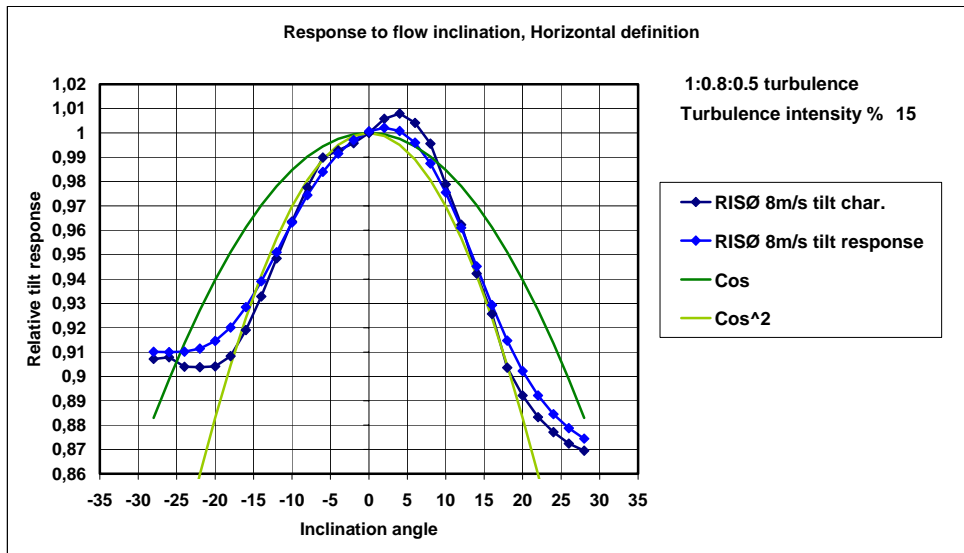

Figure 6-5 Angular response characteristics of RISØ cup anemometer with horizontal wind speed definition

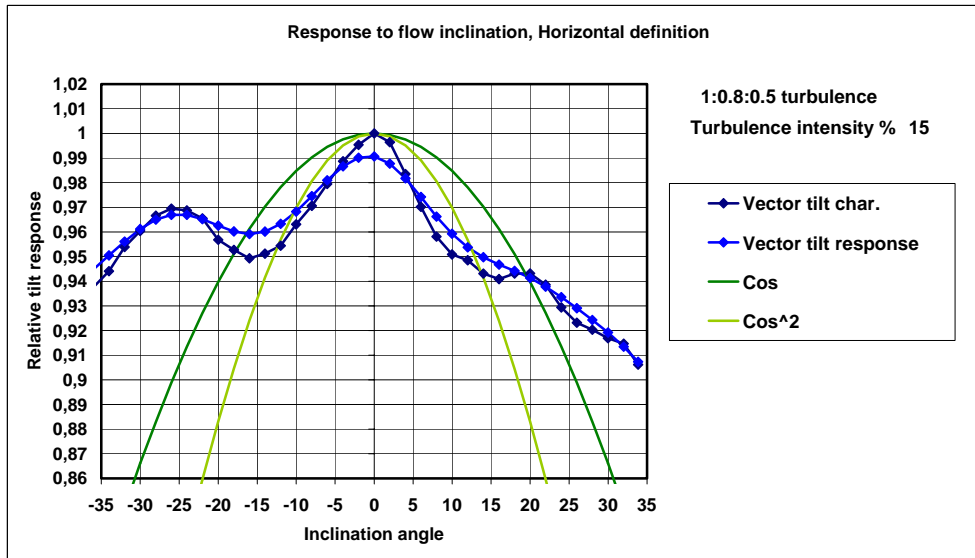

Figure 6-6 Angular response characteristics of Vector cup anemometer with horizontal wind speed definition

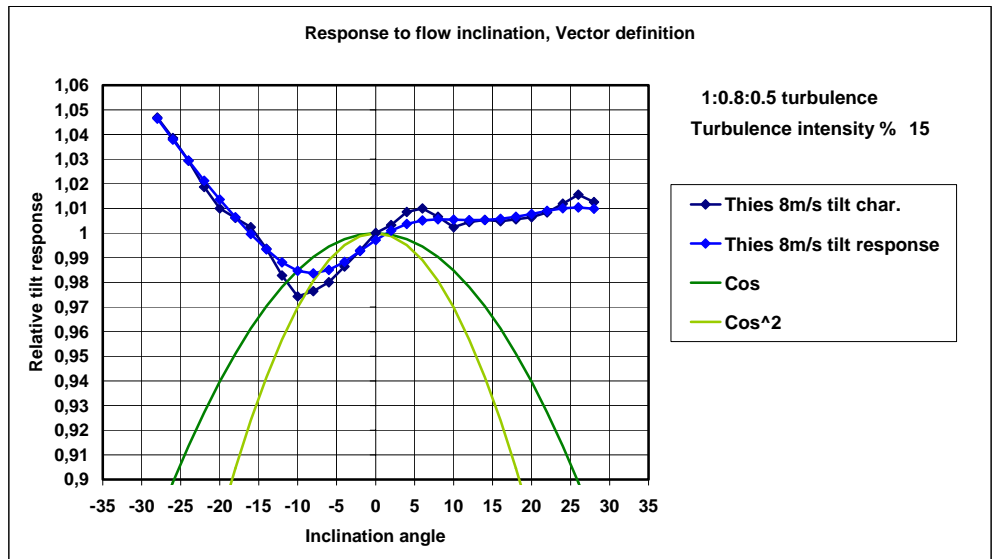

Figure 6-7 Angular response characteristics of Thies cup anemometer with vector scalar wind speed definition

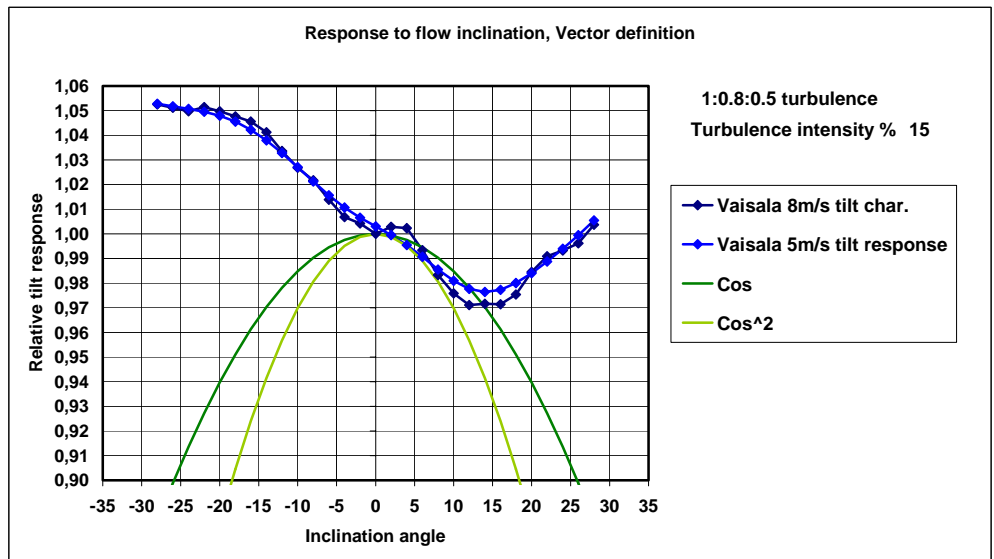

Figure 6-8 Angular response characteristics of Vaisala cup anemometer with vector scalar wind speed definition

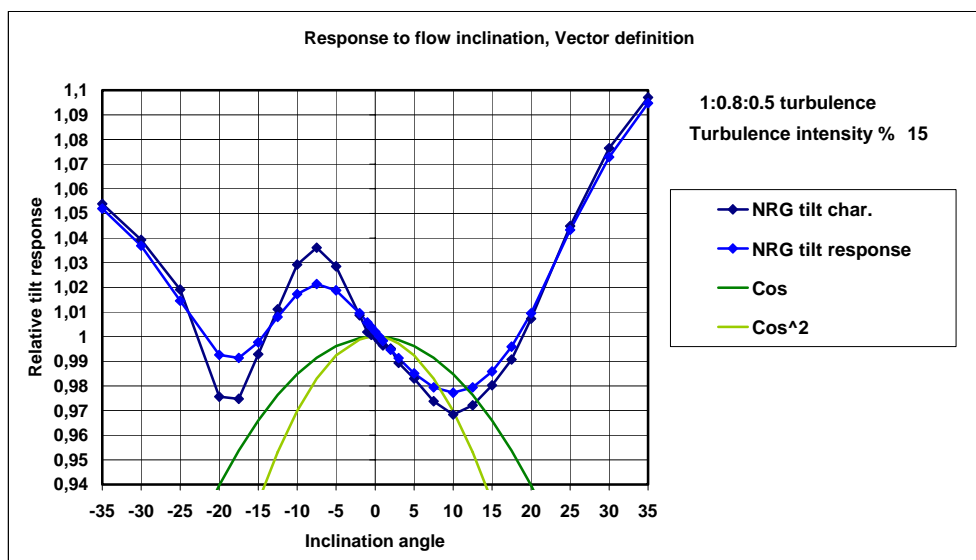

Figure 6-9 Angular response characteristics of NRG cup anemometer with vector scalar wind speed definition

The turbulence-weighted response curves can be used to find differences in response of cup anemometers to inclined flow (overspeeding not included). For instance, if a wind speed is measured in a sloped terrain with an inclined flow of 15° with a Vaisala and a RISØ cup anemometer, then the difference due to angular characteristics is -10,5%.

6.3.2 Influence of turbulence on the wind turbine

To some extent, the power production from wind turbines is sensitive to turbulence. There are not many studies that have analysed the turbulence sensitivity, and measurement of the sensitivity is influenced by a perhaps much higher turbulence sensitivity of the cup anemometer. But what is our interest in power performance measurements? Do we want to measure power curves that are turbulence sensitive, in which case the cup anemometer should measure only the average longitudinal wind speed component? Or do we want power curves to be insensitive to turbulence, in which case cup anemometers should be designed to have the same sensitivity to turbulence as the wind turbine? In the latter case, we need to know what the sensitivity of the wind turbine is.

The sensitivity of a wind turbine to turbulence can be considered by study of a blade element code, the mostly used code in wind turbine design. Figure 6-10 shows how a blade responds to turbulence in a horizontal position under clockwise rotation. A resultant wind speed and a resultant angle of attack to the profile are applied on the wind turbine blade element, due to the average longitudinal wind speed and the turbulence components. The blade element will in this case include the longitudinal u and the vertical w turbulence components in the calculations as they influence angle of attack and resulting wind speed. The lateral turbulence component v contributes to a wind speed along the blade, and can therefore not add any aerodynamic forces to the blade.

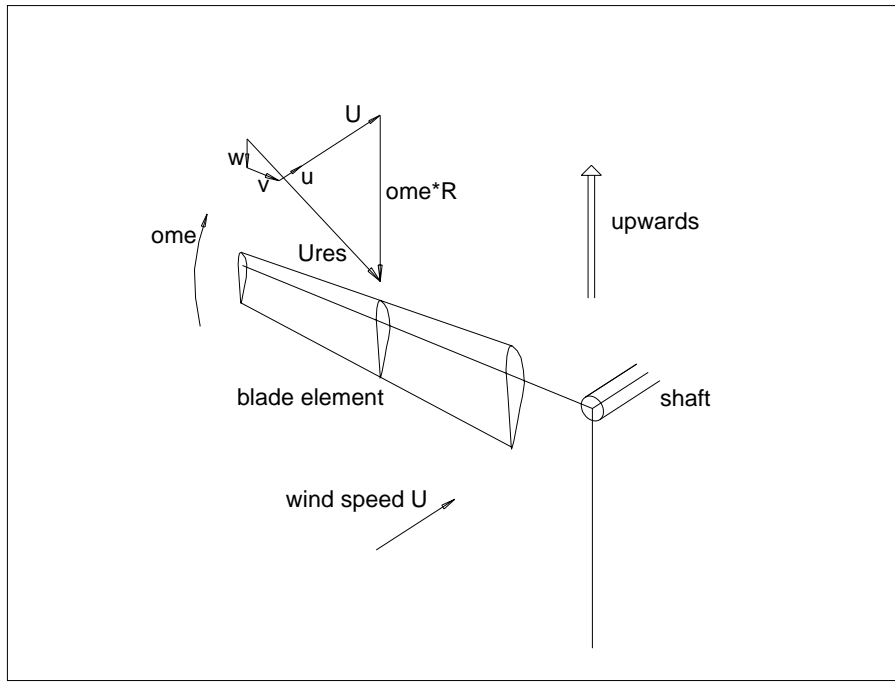

Figure 6-10 Wind vectors on a blade element with blade in horizontal position moving upwards (induction factor excluded)

When the blade moves sideward in the vertical position, see Fig. 6-11, the longitudinal u and the lateral v turbulence components contributes to the resulting angle of attack and the resulting wind speed: Now the vertical turbulence component w contributes to a wind speed along the blade, and can therefore not add any aerodynamic forces to the blade.

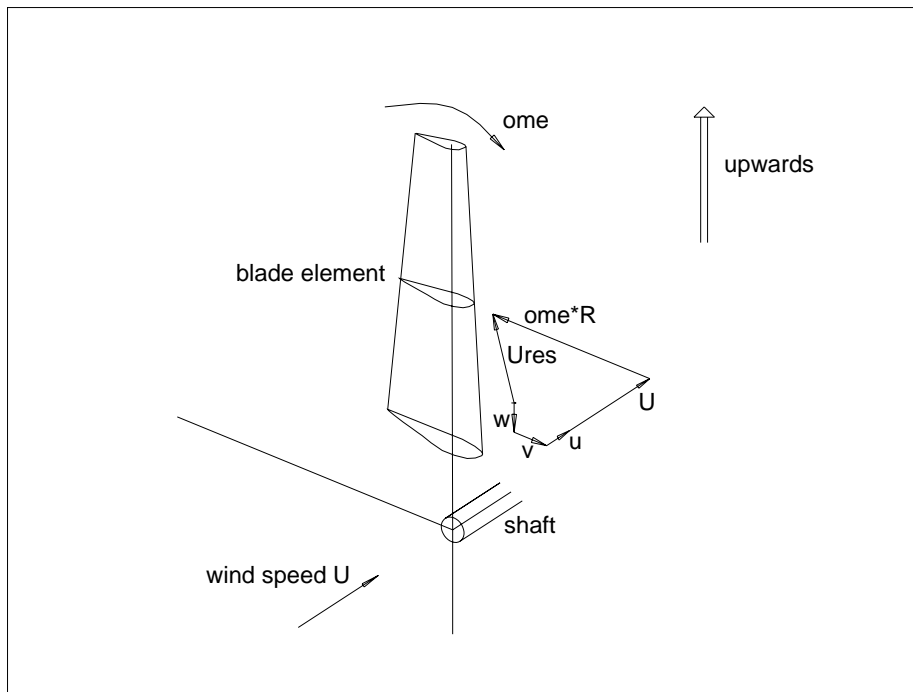

Figure 6-11 Wind vectors on a blade element with blade in vertical position moving sideways (induction factor excluded)

The only turbulence component that always contributes to the resulting angles of attack and wind speed on the profile is thus the longitudinal component u . In horizontal blade position the vertical turbulence component w also contributes, and in vertical position the lateral component v contributes. The wind turbine is influenced cyclically by a combination of the lateral and vertical components. In average the turbulence influence is a combination of the longitudinal component with the average of the lateral and vertical components. For an isotropic turbulence, the influence on the wind turbine can be regarded an average of two of the three components. For a non-isotropic flat terrain turbulence, where the relative standard deviations of the longitudinal, lateral and vertical turbulence components are 1:0.8:0.5, the influence on the wind turbine must be regarded to be dependent on somewhat less than for isotropic turbulence (in average 1.65 times longitudinal turbulence).

6.4 Conclusions regarding flow inclination and turbulence

From the analysis of the influence of flow inclination, without considering turbulence, some general conclusions can be made:

- Tilting and yawing of wind turbines reduces power but are not taken into account in power performance measurements; the effect can be substantial in complex terrain
- Tilting and yawing of wind turbines and inclined flow to the rotor are seemingly influencing power by a \cos^2 relationship
- There is no difference in power curves in flat terrain, when measured with vector scalar or horizontal defined wind speeds (not considering turbulence)
- There are substantial differences in power curves in sloped terrain with inclined flow, when measured with vector scalar or horizontal defined wind speeds; a power curve measured at 15° inclined flow has -4.8% or -2.2% of AEP compared to a flat terrain power curve when measured by a vector scalar or a horizontal defined wind speed, respectively
- Site calibration shall be made with two cup anemometers of same type and ideal angular characteristics to give “real” flow correction factors of actual flow wind speeds
- Even though a site calibration has been made, the flow correction factors do not correct objectively for the flow inclination effects at the wind turbine
- From a flow inclination point of view, the horizontal wind speed definition is preferable to the vector scalar wind speed definition

From the analysis of the influence of turbulence, the following conclusions can be made:

- A wind turbine is sensitive to the longitudinal and an average of the lateral and vertical turbulence components in flat terrain turbulence
- A wind turbine is sensitive to two out of the three turbulence components in isotropic turbulence
- A vector scalar wind speed sensor is sensitive to all three turbulence components, which makes it more sensitive to turbulence than the wind turbine

- A horizontal wind speed sensor is sensitive to the longitudinal and lateral turbulence components, which makes it about just as sensitive to turbulence as the wind turbine
- A longitudinal wind speed sensor is sensitive only to the longitudinal turbulence component, which makes it less sensitive to turbulence than the wind turbine
- From an influence of turbulence point of view, the horizontal wind speed definition is preferable to the vector scalar wind speed definition

7. Conclusions and recommendations

The main task of the project was to support the revision of the IEC 61400-12 standard on power performance measurements by analysis and research. The main results of the project are a number of notes and recommendations that was used or will be used to support the committee work in IEC-TC88-MT12, which is responsible for the revision. The following conclusions and recommendations can be summarized:

Conclusions regarding manufacturers views on power performance verification

It must be concluded that the Manufacturers desire a unification of Power Curve guarantees and procedures for verification of the Power Curve for Wind Turbines erected in complex terrain. This will assure a more transparent competition, as the wording of the guarantee does not become a commercial parameter influencing the price.

Conclusions regarding investors and bankers

The overall impression is that investors and banks are becoming increasingly professional and aware of the necessity for reliable wind studies, verification of power curves etc., using recognized independent technical consultants throughout the developing and implementation phase and rely on their expertise and advices. There are, however, still facts of major importance for the viability and success of a wind energy project that are not yet really properly understood by neither the target group nor many consultants and researchers. These facts are:

- A: The on-site measured power curve for exactly the same WTG will depend on the topography of its actual position, because the power curve becomes a characteristic of not only the WTG itself but of the topography too. At present there are no reliable methods available for such adjustments.
- B: The uncertainty of power curve measurements, even for flat terrain, is of the order of 6-8% while the statistical variation (the standard deviation) of the power curves for a given type of WTG is in the range of 2-3%. In other word, the uncertainty in making a power curve verification is several times higher than the variations looked for!
- C: The energy production is much more sensitive to errors and uncertainties in the wind study than to deviations in the power curve. Typical uncertainties of a (good) wind study are in the range of 8-12% on the derived energy production, which makes the wind the number one parameter of importance for a project.
- D: There is at present no international standard or guidelines on how to measure the wind conditions, how to transform short term measurements into long term wind conditions, how to check the flow models applied to establish a wind atlas for the site, how to deal with the involved uncertainties in measurements, modelling and transformations to hub heights etc.

Conclusions regarding study on regional correction curves for Denmark

From the analysis of regional correction curve for Denmark it can be concluded that the variation in power curve within the same type of WTG, in general, is of

the order 2-3 % and almost certainly less than 5% in any case. Since the uncertainty in power curve measurements for ideal test sites is of the order of 6-8% and for complex sites more, the value of on-site power curve measurements must be characterised as highly questionable.

When power curve measurements in complex terrain in some cases do show significant deviations in power curves for the same type WTGs, this can normally be traced back to significant terrain induced differences in the wind flow over the rotor. Since power curve measurements refer to a single point wind speed at hub height, the *same* WTG will exhibit different power performance characteristics for different terrain induced wind flow. A need therefore exists for further measurements and analyses of how the power curve (based on hub height wind speed) changes as a function of terrain complexity, especially the wind shear profile. Only then will it be possible to assess and calculate the terrain dependent changes in the power curve and thereby in the energy production which is, after all, the bottom line figure of interest for the owners and investors.

Conclusions regarding power curve comparisons by Helge Petersen

The analysis and conclusions by Helge Petersen show that differences between makes, types and power regulation configurations are very small, and that other parameters, like rotor loading can be generalized, so that individual differences from the general behaviour are very small. This emphasises, that the uncertainty in power curve measurements must be kept very small (in the order of a few percent) to be able to determine individual differences.

Conclusions and recommendations regarding cup anemometry

From the experience with cup anemometry the following conclusions and recommendations can be made:

- Cup anemometers show systematic turbulence dependent differences in field comparisons
- Neither the RISØ nor the Thies cup anemometer has any “ideal” angular characteristics for “Horizontal” or “Vector” instruments
- The difference in measured wind speed between the two definitions “vector” and “horizontal” is quite low (about 1% at 20% turbulence), and is not the explanation to the high differences shown in the field comparisons
- Angular response is not enough to explain the differences of the cup-anemometers in field comparisons.
- Dynamic overspeeding is a substantial factor that must be taken into account
- Dynamic overspeeding of cup-anemometers is more complex than previously thought. For an adequate analysis, a non-dimensional torque curve must be provided
- The RISØ cup anemometer seems to have a little negative overspeeding at 10% turbulence, but increasing positive overspeeding at higher turbulence intensities.
- The Thies cup-anemometer seems to have substantially higher overspeeding than the RISØ cup anemometer, which must be an important part of the explanation of the high differences in field comparisons
- Cup anemometers should, apart from field comparisons, be classified according to a classification system, and based on an analysis of their friction dependency, angular response and dynamic overspeeding effects under well-defined ranges of external climatic conditions. A classification system is proposed in the CLASSCUP project

- Such a classification system should be widely adopted in the wind energy community, and it should be used to estimate operational uncertainties in power performance measurements (uncertainty $u_{V_{2,i}}$ in the power performance measurement standard IEC 61400-12)
- The definition of the measured wind speed should with respect to inclined flow be based on the following considerations:
 3. Influence of flow inclination (sloped terrain and without turbulence)
 4. Influence of turbulence on the wind turbine and the wind speed sensor

Conclusions and recommendations regarding the influence of inclined flow and turbulence

From the analysis of the influence of flow inclination, without considering turbulence, some general conclusions can be made:

- Tilting and yawing of wind turbines reduces power but are not taken into account in power performance measurements; the effect can be substantial in complex terrain
- Tilting and yawing of wind turbines and inclined flow to the rotor are seemingly influencing power by a \cos^2 relationship
- There is no difference in power curves in flat terrain, when measured with vector scalar or horizontal defined wind speeds (not considering turbulence)
- There are substantial differences in power curves in sloped terrain with inclined flow, when measured with vector scalar or horizontal defined wind speeds; a power curve measured at 15° inclined flow has -4.8% or -2.2% of AEP compared to a flat terrain power curve when measured by a vector scalar or a horizontal defined wind speed, respectively
- Site calibration shall be made with two cup anemometers of same type and ideal angular characteristics to give “real” flow correction factors of actual flow wind speeds
- Even though a site calibration has been made, the flow correction factors do not correct objectively for the flow inclination effects at the wind turbine
- From a flow inclination point of view, the horizontal wind speed definition is preferable to the vector scalar wind speed definition

From the analysis of the influence of turbulence, the following conclusions can be made:

- A wind turbine is sensitive to the longitudinal and an average of the lateral and vertical turbulence components in flat terrain turbulence
- A wind turbine is sensitive to two out of the three turbulence components in isotropic turbulence
- A vector scalar wind speed sensor is sensitive to all three turbulence components, which makes it more sensitive to turbulence than the wind turbine
- A horizontal wind speed sensor is sensitive to the longitudinal and lateral turbulence components, which makes it about just as sensitive to turbulence as the wind turbine
- A longitudinal wind speed sensor is sensitive only to the longitudinal turbulence component, which makes it less sensitive to turbulence than the wind turbine
- From an influence of turbulence point of view, the horizontal wind speed definition is preferable to the vector scalar wind speed definition

8. References

- 1 IEC 61400-12 “Wind turbine generator systems - Part 12: Wind turbine power performance testing”, First edition 1998-02
- 2 EWTS-I, Ref. 2,
- 3 EWTS-II, Ref. 3,
- 4 POWASS, Ref. 4,
- 5 Hunter R., Pedersen T.F., Dunbabin P., Antoniou A., Frandsen S., Klug H., Albers A., Lee W.K., SMT project: “European Wind Turbine Testing Procedure Developments, Task 1: Measurement Method to Verify Wind Turbine Performance Characteristics”, RISØ-R-1209(EN), January 2001
- 6 Development of a Standardised Cup Anemometer Suited to Wind Energy Applications Dahlberg J-Å, J.Gustavsson, G.Ronsten, T.F.Pedersen, U.S.Paulsen, D.Westermann, Classcup JOR3-CT98-0263, Publishable Final Report, June 2001
- 7 Identification of Variables for Site Calibration and Power Curve Assessment in Complex Terrain, SITEPARIDEN, I.Antoniou, et.al, JOR3-CT98-0257, July 2001
- 8 Frandsen, S., et.al., ”Redefinition Power Curve for More Accurate Performance Assessment of Wind Farms”, Wind Energy, John Wiley & Sons, 3 2000, pp81-111
- 9 IEA performance
- 10 ECN performance
- 11 MEASNET performance
- 12 Ingham P, Nielsen P. ”Regional Production Calculations for WTGs in Denmark – Phase 2”, InterCon Report ens-001.rap, Dec 1997
- 13 Helge Petersen, Per Lundsager “Description and evaluation of international wind turbine technology” (in Danish), 1995
- 14 Helge Petersen “Powerkurveanalyser for danske og udenlandske vindmøller”, Helge Petersen Consult, December 1995
- 15 Helge Petersen ”Comparison of wind turbines based on power curve analysis”, Helge Petersen Consult, March 1998
- 16 Helge Petersen “Evaluation of wind turbine performance, 2000”, Helge Petersen Consult, April 2001
- 17 Papadopoulos, K.H., et. al. ”Effects of Turbulence and Flow Inclination on the Performance of Cup Anemometers in the Field”, Boundary-Layer Meteorology 101: 77-107, 2001
- 18 Pedersen, T.F., ”Analysis of definitions of measured wind speed” Note 7/9-2000
- 19 Pedersen T.F., “Note on Cup-Anemometry in Power Performance Measurements
- 20 Albers A., Klug H., Westermann D. “Outdoor Comparison of Cup Anemometers”, DEWEK 2000
- 21 Albers A., Klug H., Westermann D. “Outdoor Comparison of Cup Anemometers”, DEWI Magazin Nr. 17, August 2000
- 22 Albers, A., Klug, H., “Open Field Cup Anemometry” EWEC 2001, Copenhagen
- 23 Kristensen, L., ”The Perennial Cup Anemometer”, Wind Energy, John Wiley & Sons, 2 1999, pp59-75

- 24 Recommendations to Cup Anemometers Applied for Power Curve Measurements under the Danish Approval Scheme for Wind Turbines 14/1-2002, The Danish Energy Agency
- 25 Pedersen T.F., "Power Curve Measurements under Influence of Skew Airflow and Turbulence", Note 3/1-2002
- 26 Madsen, H.A. "Yaw simulations using a 3D actuator disc model coupled to the aeroelastic code HAWC". Proceedings of IEA Joint Action, Aerodynamics of wind turbines 13th symposium, Stockholm, November 29-30 2000, edited by B. Maribo Pedersen

Title and authors

Wind Turbine Power Performance Verification in Complex Terrain and Wind Farms

Troels Friis Pedersen	RISØ
Søren Gjerding	Tripod
Peter Ingham	Intercon
Peder Enevoldsen	Bonus
Jesper Kjær Hansen	NEG-Micon
Henrik Kanstrup Jørgensen	Vestas

ISBN	ISSN
87-550-3028-9	0106-2840
87-550-3029-7 (Internet)	

Department or group	Date
VEA-VMD	April 2002

Groups own reg. number(s)	Project/contract No(s)
	ENS-1363/98-0017

Sponsorship

The Danish Ministry of Energy

Pages	Tables	Illustrations	References
60	5	30	26

Abstract (max. 2000 characters)

The IEC/EN 61400-12 Ed 1 standard for wind turbine power performance testing is being revised. The standard will be divided into four documents. The first one of these is more or less a revision of the existing document on power performance measurements on individual wind turbines. The second one is a power performance verification procedure for individual wind turbines. The third is a power performance measurement procedure of whole wind farms, and the fourth is a power performance measurement procedure for non-grid (small) wind turbines. This report presents work that was made to support the basis for this standardisation work. The work addressed experience from several national and international research projects and contractual and field experience gained within the wind energy community on this matter. The work was wide ranging and addressed 'grey' areas of knowledge regarding existing methodologies, which has then been investigated in more detail. The work has given rise to a range of conclusions and recommendations regarding: guaranties on power curves in complex terrain; investors and bankers experience with verification of power curves; power performance in relation to regional correction curves for Denmark; anemometry and the influence of inclined flow.

Descriptors INIS/EDB

HORIZONTAL AXIS WIND TURBINES, POWER PERFORMANCE, ANEMOMETRY, PERFORMANCE VERIFICATION

Available on request from Information Service Department, Risø National Laboratory,
(Afdelingen for Informationsservice, Forskningscenter Risø), P.O.Box 49, DK-4000 Roskilde, Denmark.
Telephone +45 4677 4004, Telefax +45 4677 4013