



A liquid filled light distributor and a method of use

Bak, Jimmy

Publication date:
2013

Document Version
Publisher's PDF, also known as Version of record

[Link back to DTU Orbit](#)

Citation (APA):
Bak, J. (2013). A liquid filled light distributor and a method of use. (Patent No. WO2013023666).

General rights

Copyright and moral rights for the publications made accessible in the public portal are retained by the authors and/or other copyright owners and it is a condition of accessing publications that users recognise and abide by the legal requirements associated with these rights.

- Users may download and print one copy of any publication from the public portal for the purpose of private study or research.
- You may not further distribute the material or use it for any profit-making activity or commercial gain
- You may freely distribute the URL identifying the publication in the public portal

If you believe that this document breaches copyright please contact us providing details, and we will remove access to the work immediately and investigate your claim.



- (51) **International Patent Classification:**
A61L 2/10 (2006.01)
- (21) **International Application Number:**
PCT/DK2012/050299
- (22) **International Filing Date:**
16 August 2012 (16.08.2012)
- (25) **Filing Language:** English
- (26) **Publication Language:** English
- (30) **Priority Data:**
PA 2011 70447 16 August 2011 (16.08.2011) DK
- (71) **Applicant (for all designated States except US):** TECHNICAL UNIVERSITY OF DENMARK [DK/DK];
Bygning 101A, Anker Engelundsvej 1, DK-2800 Kgs. Lyngby (DK).
- (72) **Inventor; and**
- (75) **Inventor/Applicant (for US only):** BAK, Jimmy [DK/DK]; Solbakken 16, DK-2670 Greve (DK).
- (74) **Agent:** HØIBERG A/S; St. Kongensgade 59 A, DK-1264 Copenhagen K (DK).
- (81) **Designated States (unless otherwise indicated, for every kind of national protection available):** AE, AG, AL, AM, AO, AT, AU, AZ, BA, BB, BG, BH, BN, BR, BW, BY, BZ, CA, CH, CL, CN, CO, CR, CU, CZ, DE, DK, DM,

DO, DZ, EC, EE, EG, ES, FI, GB, GD, GE, GH, GM, GT, HN, HR, HU, ID, IL, IN, IS, JP, KE, KG, KM, KN, KP, KR, KZ, LA, LC, LK, LR, LS, LT, LU, LY, MA, MD, ME, MG, MK, MN, MW, MX, MY, MZ, NA, NG, NI, NO, NZ, OM, PE, PG, PH, PL, PT, QA, RO, RS, RU, RW, SC, SD, SE, SG, SK, SL, SM, ST, SV, SY, TH, TJ, TM, TN, TR, TT, TZ, UA, UG, US, UZ, VC, VN, ZA, ZM, ZW.

(84) **Designated States (unless otherwise indicated, for every kind of regional protection available):** ARIPO (BW, GH, GM, KE, LR, LS, MW, MZ, NA, RW, SD, SL, SZ, TZ, UG, ZM, ZW), Eurasian (AM, AZ, BY, KG, KZ, RU, TJ, TM), European (AL, AT, BE, BG, CH, CY, CZ, DE, DK, EE, ES, FI, FR, GB, GR, HR, HU, IE, IS, IT, LT, LU, LV, MC, MK, MT, NL, NO, PL, PT, RO, RS, SE, SI, SK, SM, TR), OAPI (BF, BJ, CF, CG, CI, CM, GA, GN, GQ, GW, ML, MR, NE, SN, TD, TG).

Declarations under Rule 4.17:

- as to applicant's entitlement to apply for and be granted a patent (Rule 4.17(ii))
- of inventorship (Rule 4.17(iv))

Published:

- with international search report (Art. 21(3))

(54) **Title:** A LIQUID FILLED LIGHT DISTRIBUTOR AND A METHOD OF USE

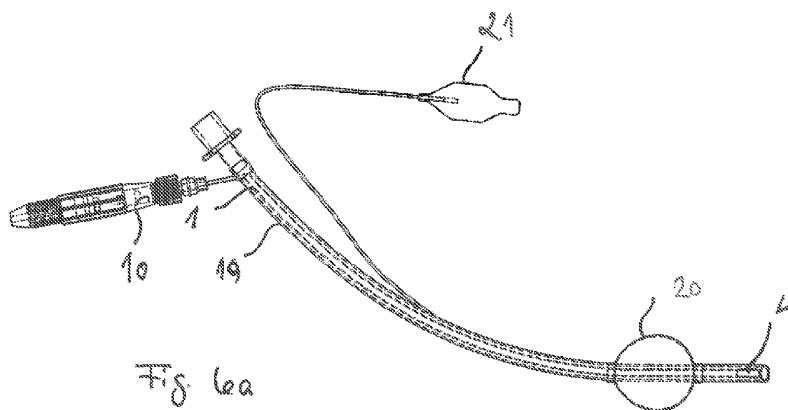

(57) **Abstract:** The present invention relates to liquid filled light distributor comprising an elongated tubular body with a tube wall defining an inner lumen filled with a liquid, said tubular body having -a proximal end closed by first closing means -a distal end closed by second closing means. Wherein the proximal end is arranged to be in optical communication with a light source and wherein the refractive index of the tube wall is n_1 and the refractive index of the fluid is n_2 and $n_1/n_2 < 1$ so that light from the light source travels along the longitudinal direction of the tubular body and that a part of the light is emitted through the tube wall along at least a part of the tubular body. Further a method of use for the liquid filled light distributor is provided.



A liquid filled light distributor and a method of use

Field of invention

5 The present invention relates to a liquid filled light distributor comprising an elongated tubular body with a proximal end and a distal end. The invention further relates to a method for disinfecting the inner lumen of a hollow body by use of the liquid filled light distributor according to the present invention.

10 Background of invention

Elongated lights sources emitting UV light e.g. from diodes and the use of the light sources to disinfect lumens in medical devices are known from e.g. US 2007/0187626. However these devices have significant drawbacks, which render them impractical and inefficient in use. For example the known sources needs to be rotated in order to be
15 able to submit an entire area of an inner wall of a lumen to disinfecting UV light as the UV sources are point sources with limited emission angle and area.

Besides the difficulties of placing the diodes inside narrow cavities/lumens electrical wiring through the length of the elongated light source is needed. If the light source is
20 used in wet or damp conditions or for medical purposes in relation to a human body, the electrical wiring, possibly in-vivo is a challenge. E.g. patient safety can be jeopardized because even small currents and voltage can be mortal. In addition, maintenance is much easier if the electrical powered light sources are ex-vivo and not in direct contact with the medical device.

25 Thus there is a need for an elongated light source emitting light continuously along the length and homogeneously around the circumference of the light source while at the same time being safe and practical in use.

30 Summary of invention

In a first aspect of the present invention as defined in the opening paragraph is provided a liquid filled light distributor which is arranged to emit light, especially UV light, over at least a part of the length of the liquid filled light distributor in a 360° radial distribution

35

In a second aspect of the present invention is provided a liquid filled light distributor which is bendable

5 In a third aspect of the present invention is provided a liquid filled light distributor which relies on non-hazardous materials

In a fourth aspect of the present invention is provided a liquid filled light distributor which relies at least partly on low cost materials

10 In a fifth aspect of the present invention is provided a liquid filled light distributor which allows a simple manufacturing process

In a sixth aspect of the present invention is provided a liquid filled light distributor which enables control of the amount and direction of the emitted light

15

In a seventh aspect of the present invention is provided a liquid filled light distributor without a source of electricity inside the light distributor.

20 In an eighth aspect of the present invention is provided a liquid filled light distributor which is disposable.

In a ninth aspect of the present invention is provided a method which allows disinfection if the inner lumen of a hollow body

25

Description of the invention

These and other aspects and advantages are achieved by a liquid filled light distributor comprising an elongated tubular body with a tube wall defining an inner lumen filled with a liquid, said tubular body having

- 30
- a proximal end closed by first closing means
 - a distal end closed by second closing means

Wherein the proximal end is arranged to be in optical communication with a light source and wherein the refractive index of the tube wall is n_2 and the refractive index of the fluid is n_1 and $n_2/n_1 < 1$. So that light from the light source propagates along the longitudinal direction of the tubular body and that a part of the light is transmitted

35

through the tube wall along at least a part of the tubular body, which thus constitutes a versatile light source which can be inserted in narrow passages.

5 The refractive index of the fluid and the refractive index of the tube wall of the tubular body is chosen to ensure that light propagates in the longitudinal direction of the tube (i.e. from the proximal end to towards the distal end) as well as it is ensured that at least part of the light is emitted through the tube wall along at least a part of the tubular body. Herby, the light distributor is effective in delivering light not only at the distal end but also radially along the length of the tubular body.

10

When the liquid filled light distributor is connected to a light source at the proximal end, light is emitted into the liquid in the lumen of the tubular body. From here the light will propagate towards the distal end of the liquid filled light distributor.

15

Whereas light theoretically under special conditions may be described as propagating in parallel with no scattering in either liquid or internal tube surfaces, this is not the case under actual circumstances. The light will enter the lumen of the tubular body with a certain spread on the propagation angle which means that light will travel towards the distal end and that part of the light will be propagating at angles different to the parallel case. When propagating light reach the tube wall it may be reflected and/or transmitted through the tube wall (refracted) depending on the relative characteristics of liquid and tube wall. It may also be absorbed in the tube wall depending on wall absorption and wall thickness.

20

25

One parameter determining the ratio between reflected and transmitted light is the relative refractive index of fluid and tube wall n_2/n_1 . In cases where $n_2/n_1 < 1$, i.e. as in the present case where the refractive index of the liquid is higher than the refractive index of the tube wall, a critical angle exists beyond which all light will be reflected on the inner side of the tube wall. The critical angle is determined by Snells law. See fig. 7.

30

This means that by selecting the relative refractive index n_2/n_1 to be lower than 1 it is possible to optimize the amount of light which stays inside the lumen of the tubular body. This is as described above due to the fact that the part of the light impinging the tube wall with an angle over the critical angle it is completely reflected and thereby

stays inside the lumen of the tubular body and may continue to propagate towards the distal end.

5 By changing the relative refractive index between liquid and tube wall, i.e. by changing the ratio n_2/n_1 , the ratio between how much light is emitted out through the tube wall and how much light stays and propagates inside the inner lumen of the tubular body is changed.

10 The proximal end can be arranged to be in optical communication with a light source in numerous ways. E.g. the proximal end may have a simple form for simply fitting into a light source or into a connector piece. Alternatively the proximal end may be arranged with means such as protrusions, guides, tread for securing directly to the light source via one or more connector pieces.

15 The second closing means of the distal end may be e.g. a film, cap, clamp or similar or even simply be a glued, pressed and/or welded part of the tubular body.

20 The first closing means may be e.g. film, glass, quartz and/or an element with selected optical properties for guiding, collecting, angling, transmitting etc. the light from the light source.

The first closing means may in some embodiments form part of an arrangement for connection and optical communication with the light source.

25 In some embodiments the refractive indices of the material that can be used for the tube wall of the light distributor are chosen to be lower than 1.33 (1.33 is the refractive index of water). If the fluid inside the light distributor is water and an ionic compound is added to the water it is possible to increase the refractive index of the liquid up to e.g. ~1.37. Some polymers (for example teflons) can have a refractive index as low as
30 1.29-1.31. Because the proportion of light that is transmitted depends on the difference in refractive index between the wall and liquid it is advantageous to have a large span between the two indices (n_1 and n_2).

35 Ratios n_2/n_1 may for example be chosen in the interval: 0.94 (e.g. 1.31/1.33) – 0.98 (e.g. 1.29/1.37).

In order to obtain a sufficient emission of light through the tube wall along at least part of the tubular body the ratio n_2/n_1 must preferably be < 0.98 or even lower e.g. < 0.96 . This is due to the fact that if the ratio becomes too high the liquid light guide will lead all light to the distal end of the tubular body with no or very limited transmission of light through the tube wall along the length of the tubular body.

The transmittance (fraction of light transmitted) through the wall depends on the absorption properties of the wall material and its thickness. The transmittance is therefore the same along the entire length of the light distributor and consequently the same fraction of light propagating along the inner space of the light distributor is emitted to the surroundings. In order to achieve an even light emission as possible along the entire length of the light distributor it may be important to guide the light to the distal as effectively as possible. This can be achieved by decreasing the ratio n_2/n_1 i.e. optimizing the light propagating properties of the light distributor.

Thus, as clear from the above, by changing the relative refractive index n_2/n_1 of liquid and tube wall it is possible to change the amount of light which propagates all the way through the tubular body to reach the distal end and the amount of light emitted radially from the tubular body.

Preferably 20 – 80% of the light is left at the distal end so that light is emitted through the tube wall along the full length of the tubular body but in a ratio which allows part of the light to be left inside the tubular body at the distal end. If 50 – 70% of the light is left at the distal end the minimal light flux through the tube wall at the distal end may be in an ideal range. However, the percentage of light left at the distal ends depends on the length of the liquid filled light distributor. Thus, the interval 50 – 70% may for example relate to the case of a 10 – 30 cm long liquid filled light distributor. If 100% light is left at the distal end no light has escaped though the tube wall. If 0% is left all light has escaped through the tube wall (and/or has been lost to absorption and similar effects) before reaching the distal end of the light distributor.

If the light distributor is short a relatively high ratio n_2/n_1 may be used. If the light distributor is long it becomes more important to have a lower ratio in order to have light left inside the light distributor at the distal end.

The attenuation of light inside the light distributor follows an exponential decay curve. In order to reduce the decay rate the transmittance through the tubular body from the proximal to the distal end should be increased. This can be achieved by decreasing the
5 ratio of the refractive indices such that the critical angle increases and light from more angles are reflected to the distal end.

If the liquid is a saline solution the liquid filled light distributor according to the invention can be safe to use and manufacture, as well as the liquid used is cheap, easy to
10 acquire and easy to dispose of. Further advantages are that saline liquid transmits light over a wide range of wave lengths including UV light, and advantageously including UVC light.

A solution made with a pure salt (e.g. NaCl) provides a liquid with no or an insignificant
15 number of impurities, which will help minimize unwanted scattering and/or absorption of the light caused by the liquid inside the tubular body.

Generally even if the fluid is not a saline solution it can be an advantage to use pure salts and fluids with a minimum of particles or other substances which may absorb or
20 scatter light for making the liquid to fill the light distributor.

Many ionic solutions are transparent in the UVC region. They will increase the refractive index of the solution compared to pure water (1.33 in the visible region) and could in principle be used. Solutions based on NaCl, however, are cheap and non-
25 poisonous which is relevant e.g. if there should be a leak when inserted into a medical device.

By controlling the salinity of the liquid it is possible to control the refractive index of the liquid, which is one of the significant parameters determining the amount of light
30 emitted through the tube wall and the amount of light propagating from the proximal end to arrive at the distal end of the liquid filled light distributor. Salt concentration of the saline solution may be at least 10 g/100ml, at least 20 g/100 ml or even 30 g/100 ml or higher. The refractive index of the saline solution depends on the salt concentration in that the refractive index of the saline solution is increased when the
35 salt concentration is increased.

From CRC chemical handbook we can make a table that give the refractive indices for different NaCl solutions (and others as well). For instance:

5 0% (pure water) = 1.33
 5% = 1.34
 10%= 1.35
 20%= 1.37
 26%= 1.38

10

For visual light, however these factors are also applicaple in the case of UV light.

Dupont's AF Teflon: 1.29

FEP teflons: ~1.30-1.31

15 PTFE teflons ~1.30-1.33

The refractive index of the liquid can be adjustable by simple means e.g. by changing the concentration of a content such as a salt.

20

If other liquids than saline are used they are preferably chosen to have a high transmission in relevant wave length ranges, e.g. with a high transmission of UVC light, chosen to have a low amount of impurities in order not to absorb and disperse the light propagating in the lumen of the tubular body, be non-hazardous and/or cheap. Also used liquids must satisfy the requirements to refractive index relevant to embodiments of the invention. The refractive index of the liquid can be adjustable by simple means e.g. by changing the concentration.

25

In order to obtain a reasonable even light distribution along the length of the light distributor the transmission through the light distributor may in many embodiments preferably be as high as possible. The fraction 'f' of light emitted (or transmitted) through the wall at a distance 'L' from the light source is the same as the fraction emitted at 'L+x'. If the light intensity 'I' is strongly attenuated close to the light source only a small part will be emitted in the distal end: $I(L+x)^*f$. If the light that reaches the

30

distal end can be back reflected an even more even emission from the light source may be accomplished.

5 In several preferred embodiments the distal end is coated with a reflective material. By coating the distal end with a reflective material or otherwise providing a reflective material to the distal end of the lumen of the tubular element and/or to the second closing means, light which has propagated from the proximal end to the distal end will be reflected back through the liquid in the lumen of the tubular body towards the proximal end.

10

Reflective materials may include different kinds of film or coating of one or more metals such as a silver coating or more preferable an aluminum coating as this can provide a very high reflectivity.

15

The reflection of the light back through the liquid filled light distributor means that the overall transmission through the tube walls may be increased. Also it means that it is possible to use the liquid filled light distributor as a light source in a channel wherein it is desired to subject the walls of the channel to light while at the same time preventing light escaping through the end of the channel, as light is only emitted radially from the tubular body and not through the distal end itself or and/or through the second closing means.

20

The liquid filled light distributor may also be arranged with a reflective material in other regions where it is preferred to avoid emission of light and from where it is advantageous that light is reflected to stay inside the lumen of the tubular body of the light distributor. The reflective material may be permanent or removable e.g. in the form of a removable sleeve.

25

Advantageously the material and/or thickness of the tube wall may be selected to optimize the desired properties of the liquid filled light distributor of the present invention. A liquid filled light distributor can also comprise a tubular body made of more than one material and/or with one or more wall thicknesses.

30

Thus, the material(s) may be chosen to have a refractive index which helps provide a desired n_1/n_2 ratio as well as the wall thickness may be chosen in order to achieve desired transmission properties of light through the tube wall.

5 Preferably the material of the tube wall has a thickness of less than 0.15 mm, preferably less than 0.10 mm or even down to 0.05 mm or less as this may ensure specific mechanical properties while keeping the amount of light lost to absorption in the tube wall at a minimum.

10 If the tube wall is too thick too much light may be absorbed by the material of the tube wall.

If the tube wall is too thin the strength of the tube wall may be compromised. The ability to provide a thin tube wall depends on the type of material chosen for the tube wall.

15

Preferred tube wall materials includes: Teflon such as Fluorinated ethylene propylene (FEP), polytetrafluoroethylene (PTFE), amorphous fluoropolymers (AF) as they have low refractive indices. Different types of foils and thin sheets of polymers may also be highly transparent to UV and preferably to UV C light and thus be usable for use in the present invention.

20

By mechanical properties are meant e.g. strength, flexibility, shear strength, transmission, impermeability to the given liquids inside the inner lumen etc.

25 It may also be advantageous to manufacture the tube wall in a material which makes it possible to obtain a smooth inner surface of the tube wall as this will minimize the scattering of the light reflected off the tube wall inside the lumen.

30 In preferred embodiments the proximal end is arranged with a connector piece which allows easy connection to a light source. Preferably the connector piece is arranged to minimize the loss of light from the light source. I.e. the connector piece may be arranged not to hinder the transmission of light from the light source to the proximal end of the liquid filled light distributor of the present invention.

The connector piece can in various embodiments be e.g. luer locks, different type of locks which “clicks” together, unions or other threaded lock systems.

5 In further preferred embodiments the tubular body is flexible as this allows the insertion of the liquid filled light distributor in lumens, passages, channels etc. which may be bend or otherwise have obstacles which will prevent the insertion of a rigid liquid filled light distributor.

10 Light source used together with the liquid filled light distributor can for example be UV diodes (LEDs), visible LEDs, laser light sources, bulbs with or without optics etc.

Alternatively the light source may comprise a light guide such as an optical fibre whereto the light distributor according to the present invention can be connected. Hereby a wider span is achieved making e.g. in vivo diagnostics possible in areas
15 which otherwise may be hardly assessed. Also the options for Photo dynamic Therapy (PDT) will be increased due to the wide range in which the optical fibre in connection with the light distributor according to the present invention may be effectively operated offering unique options to reach and treat otherwise hard to reach areas.

20 In several embodiments the light distributor comprises one or more transmitting fields. These transmitting fields are preferably made of one or more materials which transmits lights and which does not guide the light. For example such transmitting fields may be of COC polymer materials or other materials with a refractive index chosen depending on the refractive index of the fluid inside the light distributor to ensure that light is
25 transmitted through the transmitting field. This also means that in advantageous embodiments the material of the transmitting field does not guide the light inside the liquid light distributor but lets it escape through the transmitting field. Transmitting fields may thus function as a transparent window through which more light is emitted from the liquid filled light distributor than from the rest of the light distributor.

30 The transmitting fields can be an integrated or added part of the liquid filled light distributor arranged in selected areas or e.g. the transmitting fields can be a tube section or end piece optionally functioning as the second closing means. If the diameter of such a tube section or end piece is selected to be different from the general
35 diameter of the liquid filled light distributor specific illumination properties can be

achieved. For example the diameter of a transmitting field in form of an end piece can be larger than the diameter of the main part of the liquid light distributor and thus function as a more intense light source compared to the light emitted from the rest of the liquid filled light distributor.

5

Preferably the light source is a UV C source as UV C light is effective as a disinfecting agent. This also means that mentioned UV transmitting materials is preferably transmitting UV C light with a minimum loss.

10 If the tube wall is transparent to UV light many advantageous embodiments may be achieved wherein this special property is utilized.

The properties of the UV light are further enhanced if the first closing means is a UV transparent film as this means that UV light from the light source connected to the tubular light source by the proximal end is allowed to pass into the lumen of the tubular light source.

15

Alternative light transmitting and especially UV light transmitting materials may be used for the first closing means.

20

In several embodiments the liquid filled light distributor is arranged with parts which is intended and suited for single use only. I.e. the liquid filled light distributor can be disposable.

25 For a disposable liquid filled light distributor it may be advantageous that the different parts such as tube wall, connectors, closing means and/or liquid are chosen to be cheap and/or non-toxic.

The properties of the liquid, tube wall and first closing means, which allows the propagation and emission of UV light provides a number of important abilities to the liquid filled light distributor according to the present invention.

30

Thus, according to the present invention a versatile liquid filled light distributor is achieved and especially a liquid filled light distributor which may be used to disinfect hard to reach places and narrow channels are provided.

35

The inventors of the present invention have surprisingly shown that the emission through the tube wall which is considered unfavourable side effect and imperfection in other setups known from traditional light guides is in fact a useful and tuneable feature which can be utilized with great advantages.

For example a liquid filled light distributor according to the present invention can be used to disinfect the inner channel of a device. UV light is known for its germicidal properties and the present invention when used to distribute, emit and guide UV light may advantageously be used to disinfect hard to reach places inside e.g. a channel in an object. The fact that light can be emitted radially along the full length of the tubular body of the present invention means that e.g. a channel can be completely subjected to UV light by use of the present invention. The present invention can even be used without the need to turn or otherwise reposition the liquid filled light distributor during use.

The present invention can also be used to e.g. UV hardening of materials such as plastics or glues in situations where known UV light guides may be less applicable as they only emit light at the end. Also the present invention can be used as an alternative light source with or without UV light in conditions which require insertion in narrow, wet and/or damp spaces and where the light distributing properties of the liquid filled light distributor according to the present invention may be useful.

Especially advantageously the liquid filled light distributor can be used to disinfect the inner channel of a medical device such as an EndoTracheal Tube (ETT) before and/or during use. Depending on how the refractive indexes n_1 and n_2 are chosen the tubular liquid filled light distributor can be configured to disinfect the full length of a channel by allowing UV light to be emitted though the full length of the light distributor. Preferably n_1 and n_2 are chosen in order to have a 40 – 70% light left in the lumen at the distal end in order to achieve a high transmission of UV light through the tube wall at the distal end.

When the present invention is used the lights source can be placed outside the human body in medical applications and then avoid the need for in vivo placement of electrical

wires as it would be required if an elongated light source with LEDs as previously known was used.

5 The fact that no electrical installations or other type of charges are required inside the light distributor according to the present invention also allows the use of the present invention as a light source in spaces filled with combustible materials as gases or fluids. This offers a safe alternative to other more traditional lights sources also under these demanding conditions.

10 It is also possible that the transmission of UV light through the tube wall along at least a part of the tubular body and/or at the distal end is adjusted (by selecting appropriate n_2/n_1 ratio, materials and tube wall thickness) in order to keep a device sterile. This is for example relevant if the liquid filled light distributor according to the present invention is inserted into a sterile lumen in a device and is operated over prolonged time in order
15 to maintain the inner lumen of the device in a disinfected state.

The liquid filled light distributor can be permanently or removeably inserted into the device in which it is used. It is also possible that the liquid filled light distributor can be an integrated part of a device e.g. a medical device.

20

The advantages of the present invention are also achieved by a method of disinfecting the inner lumen of a hollow body at least comprising the steps of

- Acquiring a liquid filled light distributor
- Connecting the liquid filled light distributor with a tubular body to a UV source
- 25 - Inserting the liquid filled light distributor with a tubular body into the inner lumen of the hollow body
- Submitting the inner lumen of the hollow body to UV light via the liquid filled light distributor with a tubular body for a period of time

30 Preferably the liquid filled light distributor used in the method is a liquid filled light distributor according to the present invention and thus the method may provide all the advantages and possibilities described in the previous sections.

The method according to the present invention is especially useful if the hollow body is
35 a medical device

The method can even be used if the medical device is operational during the sterilization process. This can for example be in the case where a ETT in a patient is kept sterile by use of the present invention. In this case it is especially advantageous if the distal end and/or second closing means is provided with a reflective material as this will ensure that only the inner lumen of the ETT receives the UV light and that no UV light reaches any parts of the patient.

10 Description of Drawings

Fig. 1 shows a liquid filled light distributor according to the present invention before insertion in a connector piece.

Fig. 2 shows an enlarged cross section taken along the line II-II indicated in fig. 1

15

Fig. 3 shows the liquid filled light distributor known from fig. 1 arranged with the connector piece

Fig. 4 shows the liquid filled light distributor from fig. 1 and 2 together with and light source and an additional connection

20

Fig. 5a and 5b illustrates different configurations of reflective material applied to the liquid filled light distributor

25

Fig. 5c and 5d illustrates different configurations of transmitting fields

Fig. 6a and 6b show the use of a liquid filled light distributor in an ETT

Fig. 7 illustrates refraction, critical angle and light propagation in the liquid filled light distributor.

30

Detailed description of the invention

Fig. 1 shows a liquid filled light distributor 1 with an elongated tubular body 2. The liquid filled light distributor 1 has a proximal end 3 with an opposing distal end 4. The

35

proximal end 3 is closed with a first closing means 5 and the distal end is closed with second closing means (not shown) thus an inner lumen (not shown) is formed along the full length of the liquid filled light distributor 1.

5 In fig. 2 is shown an enlarged cross section as indicated in fig. 1 the elongated tubular body 2. The elongated tubular body has a tube wall 6 around an inner lumen 7.

Fig. 3 shows the liquid filled light distributor 1 known from fig. 1 and 2 inserted in a connector piece 8. The liquid filled light distributor 1 may be fixatedly or releasably
10 connected to the connector piece 8. The connector piece 8 has a through going bore 9 allowing optical communication with a light source (not shown).

Fig. 4 shows the liquid filled light distributor 1 with the connector piece 8 ready to be connected to a light source 10 via an intermediate connector 11. In this embodiment
15 the light source comprises a LED 12 in a housing 13. The housing 13 has a threaded part 14 for connecting to the intermediate connector 11. The intermediate connector has a first part 15 for receiving the housing 13 of the light source 10 and a second part for receiving part of the connector piece 8 on the liquid filled light distributor 1.

20 When the liquid filled light distributor 1 is connected to the light source 10, light will propagate through the liquid along the length direction of the liquid filled light distributor 1 i.e. along the longitudinal direction of the tubular body. On the way towards the distal end of the liquid filled light distributor 1, part of the light will be emitted through the tube wall 6.

25 Fig. 5a shows a liquid filled light distributor 1 as known from the previous figures with a reflective material 17 applied at the distal end 4. In the shown embodiment the reflective material extends onto the tube wall 6 in an area close to the very tip of the liquid filled light distributor 1. In other embodiments (not shown) the reflective material
30 can be applied onto only the end surface 18 if desired. Fig. 5b shows how reflective material can be applied in other areas of the tube wall of the elongated body in order to direct and limit the emitted light from the liquid filled light distributor 1 to specific areas. The reflective material can cover e.g. larger circumferential areas as illustrated by the area 17a near the connector piece 8 and/or it may form stripes 17b along the length
35 direction of the liquid filled light distributor 1.

Fig. 5c and 5d shows examples of liquid filled light distributors comprising transmitting fields 22 in areas selected to enable higher transmission of light in specific areas. In fig. 5c the light transmitting field 22 is a rectangular window 23 arranged near the distal end of the light distributor. In fig. 5d the light transmitting field 22 is formed by an end piece 24 with a larger diameter than the main part of the light distributor.

Fig. 6a and fig. 6b show examples of light distributors 1 according to the present invention used to illuminate and hereby help minimize the contamination of the inside of an ET tube 18. The ET tube is arranged with a balloon cuff 19 and a device 20 for inflating the cuff 19. In the figures 6a and 6b the part of the liquid filled light distributor which is inside the ET tube is illustrated with broken lines.

Fig. 6a show an exemplary arrangement wherein the light distributor according to the present invention is arranged to illuminate the full length of the ET tube 18.

In fig 6b the light distributor according to the present invention is introduced into the ET tube closer to the distal end of the ET tube and is thus arranged to illuminate a shorter part of the ET tube.

As described earlier the light distributor according to the present invention can be arranged as a separate part for introduction into the ET tube or it may be completely or partly integrated into the ET tube e.g. during manufacturing of the ET tube.

Fig. 7 illustrates how light with different propagation angles Θ_1 from a light source will be refracted as illustrated by arrow a or reflected as illustrated by arrow c at a surface between two mediums. The refraction and reflection depends on whether the light impinges the surface at an angle lower or higher than the critical angle Θ_c .

Claims

1. A liquid filled light distributor comprising an elongated tubular body with a tube wall defining an inner lumen filled with a liquid, said tubular body having
- 5 - a proximal end closed by first closing means,
 - a distal end closed by second closing means,
- wherein the proximal end is arranged to be in optical communication with a light source and wherein the refractive index of the tube wall is n_1 and the refractive index of the fluid is n_2 and $n_1/n_2 < 1$ so that light from the light source travels along the longitudinal
- 10 direction of the tubular body and that a part of the light is emitted through the tube wall along at least a part of the tubular body.
2. Liquid filled light distributor according to claim 1, wherein the liquid is a saline solution.
- 15
3. Liquid filled light distributor according to claim 1 or 2, wherein the salt concentration of the saline solution is at least 10 g/100ml, preferably at least 20 g/100 ml more preferably 30 g/100 ml.
- 20
4. Liquid filled light distributor according to claim 1, 2 or 3, wherein $n_1/n_2 < 0.98$, more preferably $n_1/n_2 < 0.96$.
5. Liquid filled light distributor according to any of the preceding claims, wherein the distal end of the inner lumen is coated with a reflective material.
- 25
6. Liquid filled light distributor according to any of the preceding claims, wherein 20 – 70% of the light is left at the distal end, more preferably 40 – 60% of the light is left at the distal end.
- 30
7. Liquid filled light distributor according to any of the preceding claims, wherein the material of the tube wall has a high transparency to UV light.
8. Liquid filled light distributor according to any of the preceding claims, wherein the material of the tube wall has a thickness of less than 0.15 mm, preferably less than 0.05
- 35 mm.

9. Liquid filled light distributor according to any of the preceding claims, wherein the proximal end is arranged with a connector piece.

5

10. Liquid filled light distributor according to any of the preceding claims, wherein the tubular body is flexible.

11. Liquid filled light distributor according to any of the preceding claims, wherein the first closing means is a UV transparent film.

10

12. Liquid filled light distributor according to any of the preceding claims, comprising one or more transmitting fields preferably arranged near or as part of the distal end and/or second closing means.

15

13. Use of the liquid filled light distributor to disinfect the lumen of a device.

14. Use of the liquid filled light distributor to disinfect the lumen of a medical device.

15. Method of disinfecting the inner lumen of a hollow body at least comprising the steps of:

20

- Acquiring a liquid filled light distributor with a tubular body,
- Connecting the liquid filled light distributor with a tubular body to a UV source,
- Inserting the liquid filled light distributor with a tubular body into the inner lumen of the hollow body,

25

submitting the inner lumen of the hollow body to UV light via the liquid filled light distributor with a tubular body for a period of time.

16. Method according to claim 15, wherein the liquid filled light distributor is a liquid filled light distributor according to claim 1 – 12.

30

17. Method according to claim 15 or 16 wherein the hollow body is a medical device.

18. Method according to any of the preceding claims 15 – 17, wherein the medical device is operational during sterilization.

35

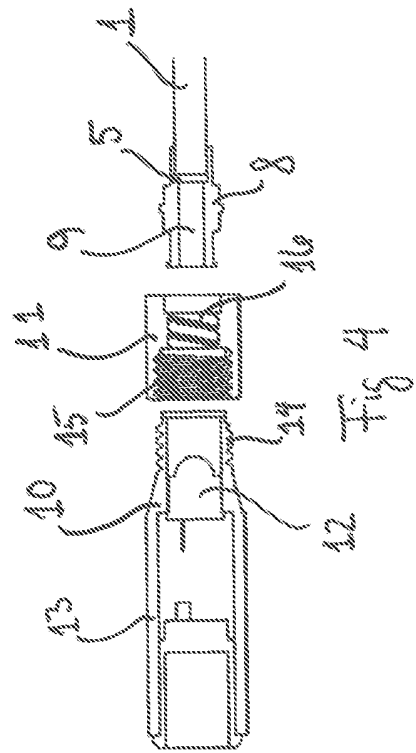
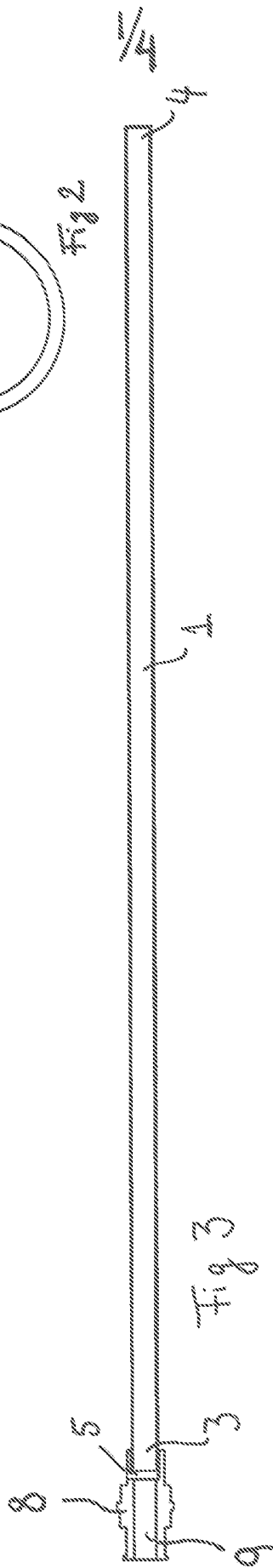
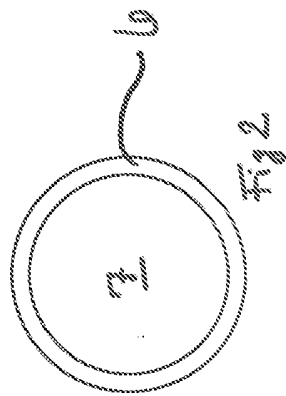
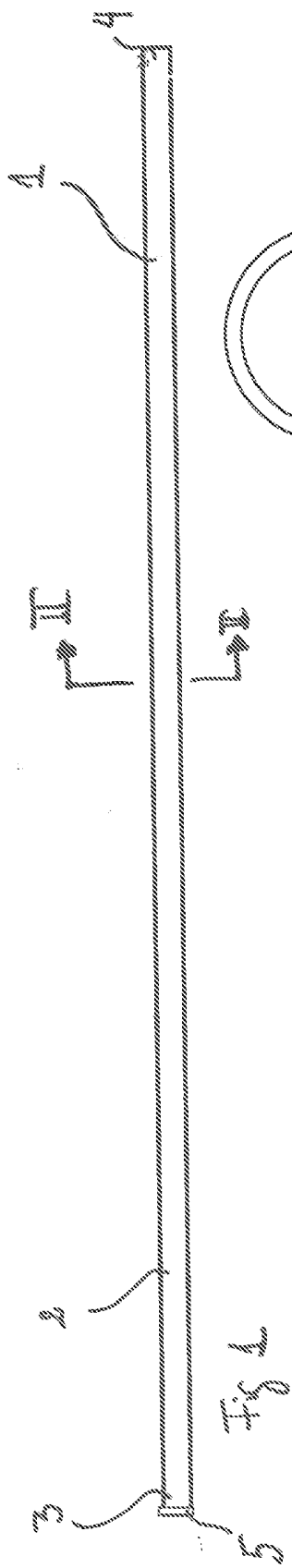

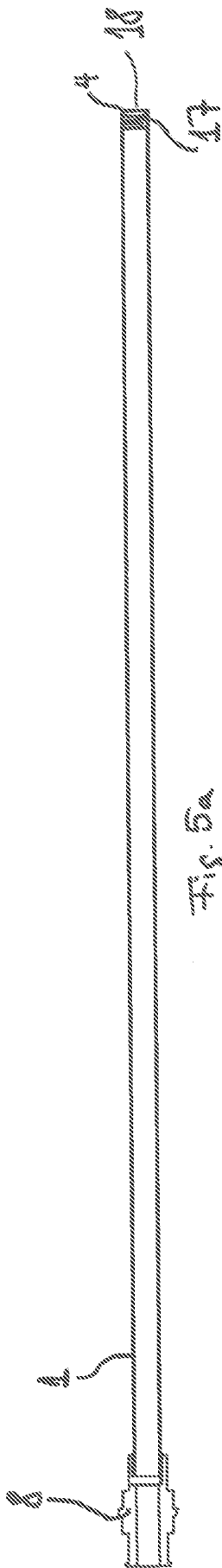

Fig. 5a

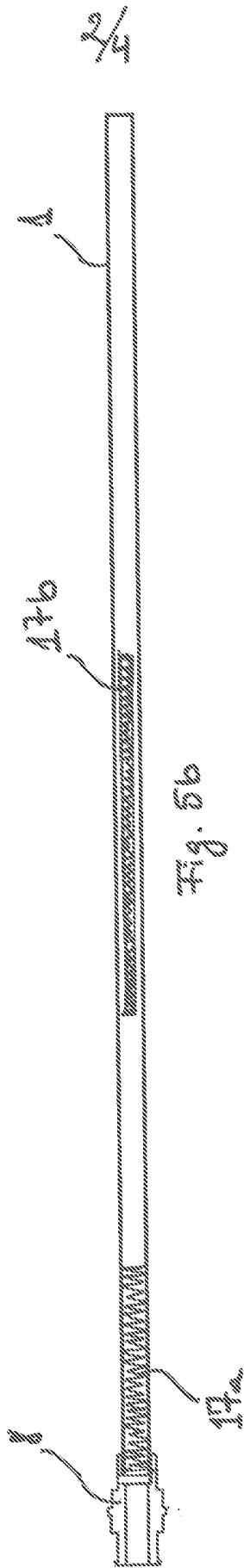

Fig. 5b

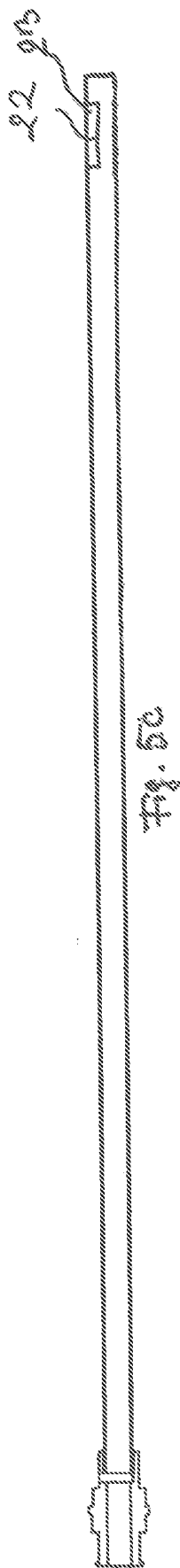

Fig. 5c

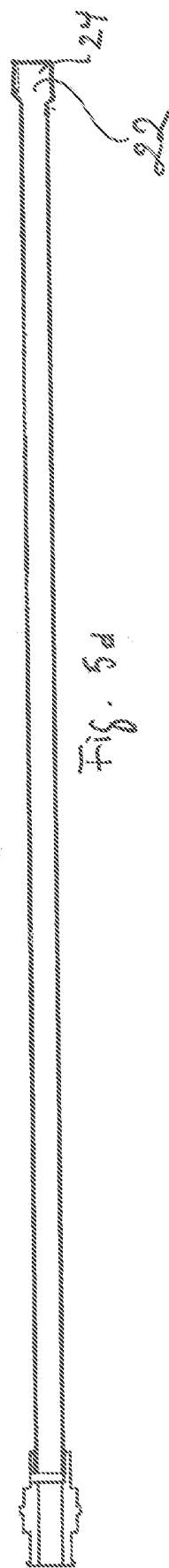

Fig. 5d

3/4

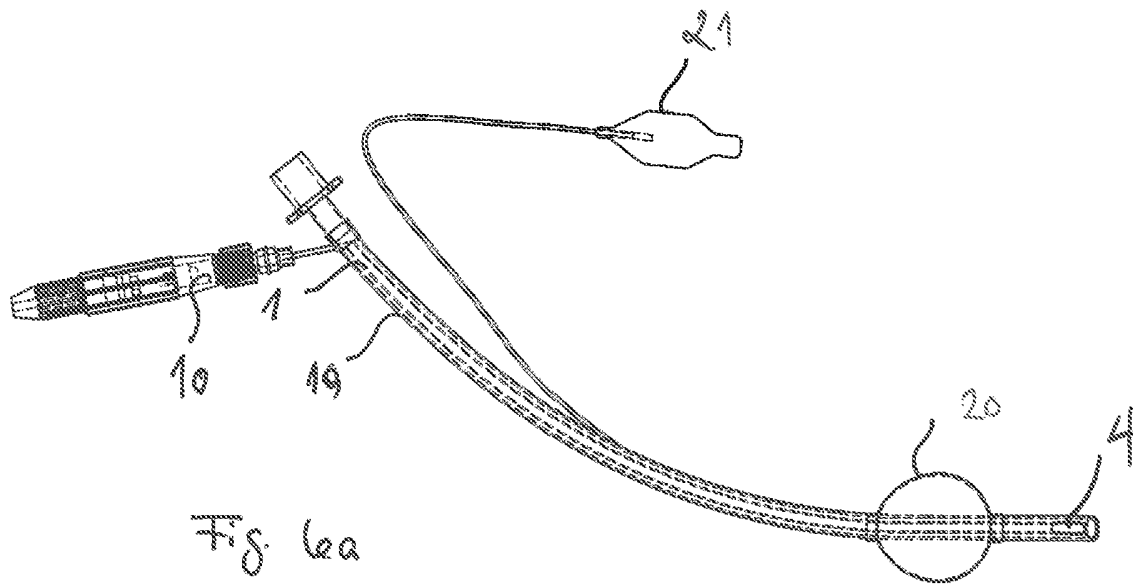

Fig. 6a

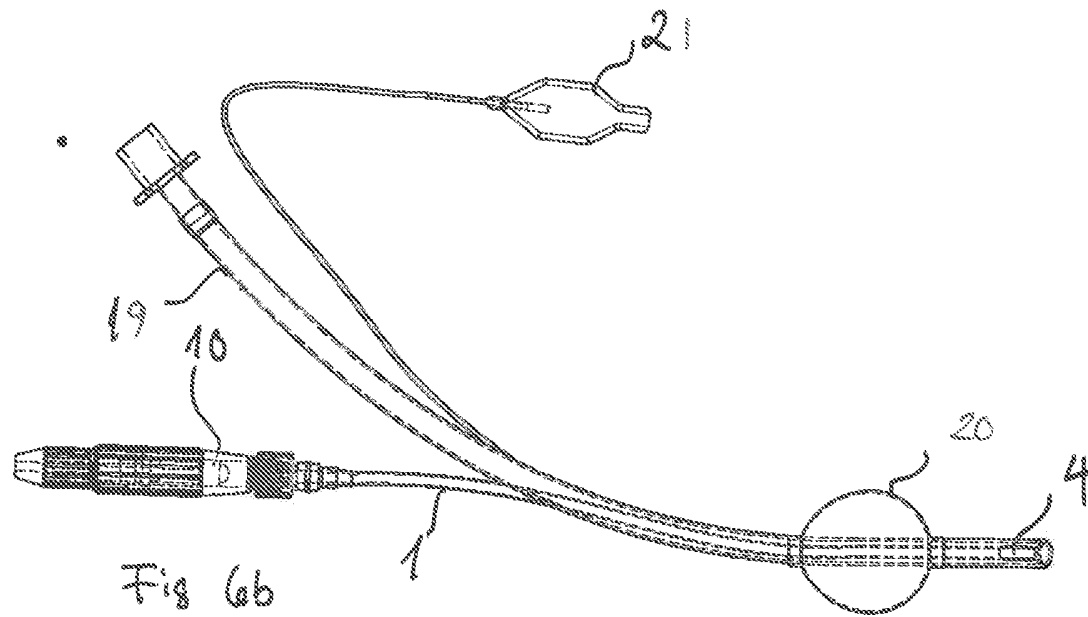

Fig. 6b

4/4

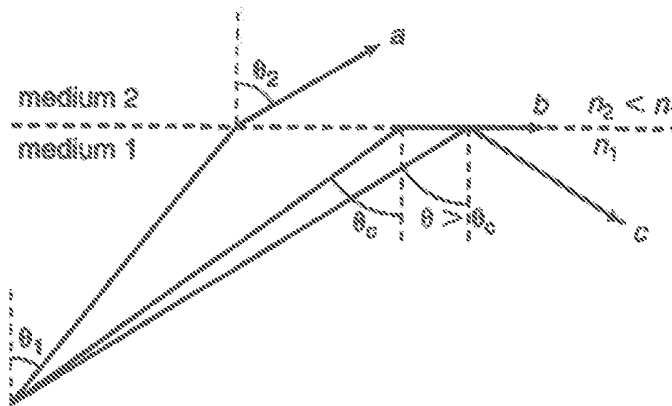

Fig 7

INTERNATIONAL SEARCH REPORT

International application No PCT/DK2012/050299

A. CLASSIFICATION OF SUBJECT MATTER

INV. A61L2/10
ADD.

According to International Patent Classification (IPC) or to both national classification and IPC

B. FIELDS SEARCHED

Minimum documentation searched (classification system followed by classification symbols)
A61L

Documentation searched other than minimum documentation to the extent that such documents are included in the fields searched

Electronic data base consulted during the international search (name of data base and, where practicable, search terms used)

EPO-Internal, WPI Data

C. DOCUMENTS CONSIDERED TO BE RELEVANT

Category*	Citation of document, with indication, where appropriate, of the relevant passages	Relevant to claim No.
X	EP 2 161 040 A1 (UNIV DANMARKS TEKNISKE [DK]) 10 March 2010 (2010-03-10) claims 1,14,15,16; figure 3 -----	1-14
X	WO 2010/097499 A1 (MAEKI MARKUS [FI]) 2 September 2010 (2010-09-02) claim 2 -----	1
A	WO 99/32181 A1 (MATTER JEAN PAUL [US]) 1 July 1999 (1999-07-01) claims 4,5; figure 1 -----	1
A	WO 2007/095543 A2 (SENSOR ELECTRONIC TECHNOLOGY I [US]; GASKA REMIGIJUS [US]; SHUR MICHAEL) 23 August 2007 (2007-08-23) claim 1; figure 1 -----	1

Further documents are listed in the continuation of Box C.

See patent family annex.

* Special categories of cited documents :

"A" document defining the general state of the art which is not considered to be of particular relevance

"E" earlier application or patent but published on or after the international filing date

"L" document which may throw doubts on priority claim(s) or which is cited to establish the publication date of another citation or other special reason (as specified)

"O" document referring to an oral disclosure, use, exhibition or other means

"P" document published prior to the international filing date but later than the priority date claimed

"T" later document published after the international filing date or priority date and not in conflict with the application but cited to understand the principle or theory underlying the invention

"X" document of particular relevance; the claimed invention cannot be considered novel or cannot be considered to involve an inventive step when the document is taken alone

"Y" document of particular relevance; the claimed invention cannot be considered to involve an inventive step when the document is combined with one or more other such documents, such combination being obvious to a person skilled in the art

"&" document member of the same patent family

Date of the actual completion of the international search

6 November 2012

Date of mailing of the international search report

14/11/2012

Name and mailing address of the ISA/

European Patent Office, P.B. 5818 Patentlaan 2
NL - 2280 HV Rijswijk
Tel. (+31-70) 340-2040,
Fax: (+31-70) 340-3016

Authorized officer

Fischer, Michael

INTERNATIONAL SEARCH REPORT

Information on patent family members

International application No PCT/DK2012/050299

Patent document cited in search report	Publication date	Publication date	Patent family member(s)	Publication date
EP 2161040	A1	10-03-2010	NONE	

WO 2010097499	A1	02-09-2010	EP 2401067 A1	04-01-2012
			US 2011309032 A1	22-12-2011
			WO 2010097499 A1	02-09-2010

WO 9932181	A1	01-07-1999	AU 1713199 A	12-07-1999
			US 5855203 A	05-01-1999
			US 6443147 B1	03-09-2002
			WO 9932181 A1	01-07-1999

WO 2007095543	A2	23-08-2007	US 2007187626 A1	16-08-2007
			WO 2007095543 A2	23-08-2007
